

TOMBO™ BRAND
GASKETS

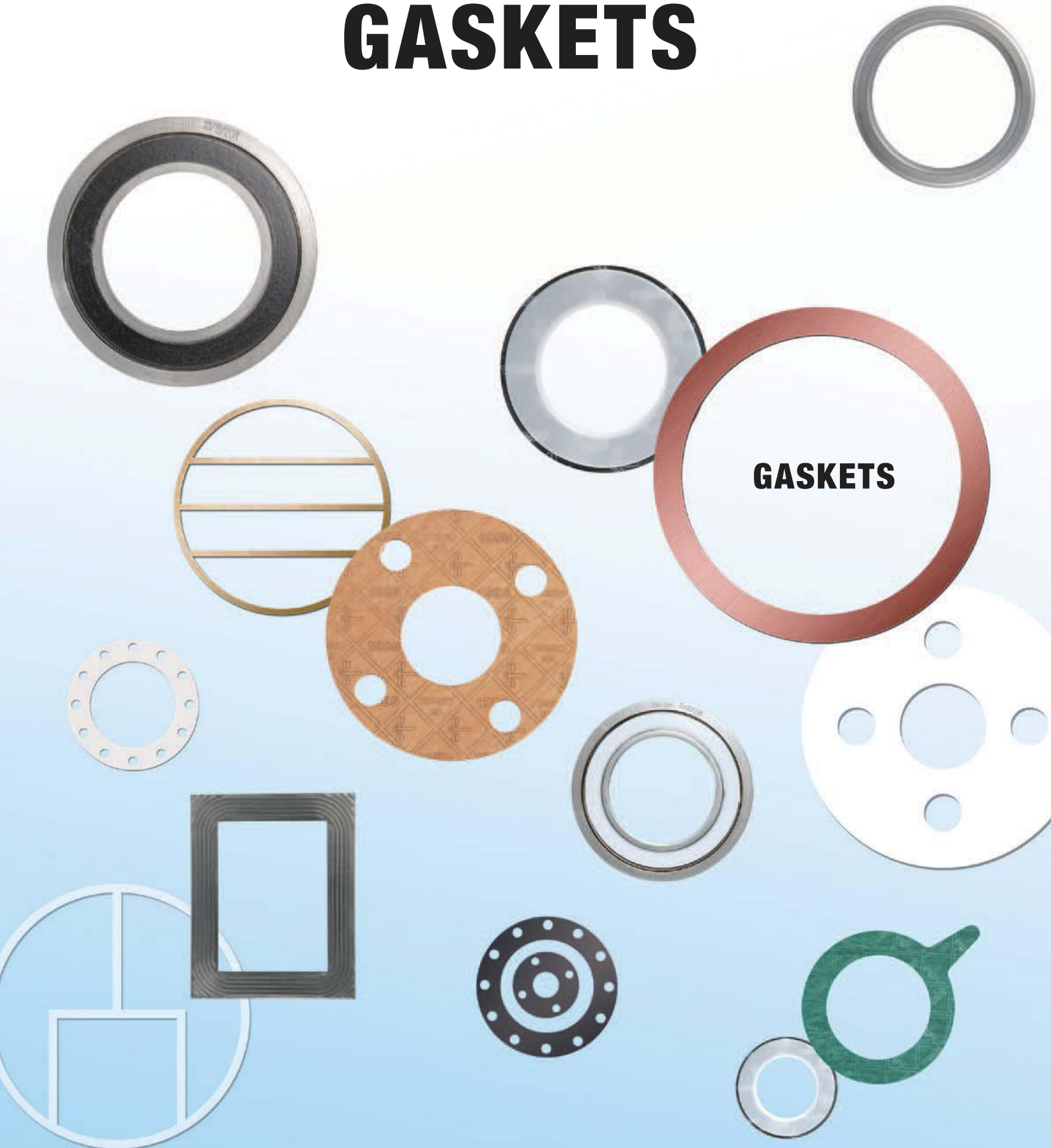



TOMBO™ BRAND GASKETS

TOMBO™ BRAND GASKETS

Gaskets perform an important role in the prevention of fluid leakage from pipes and equipment parts, in a wide range of fields such as petroleum refining, chemical industry, shipping, construction, electric power, and steelmaking. Nichias pursues the satisfaction of the customer using its sophisticated “Insulation and Protection” technology.

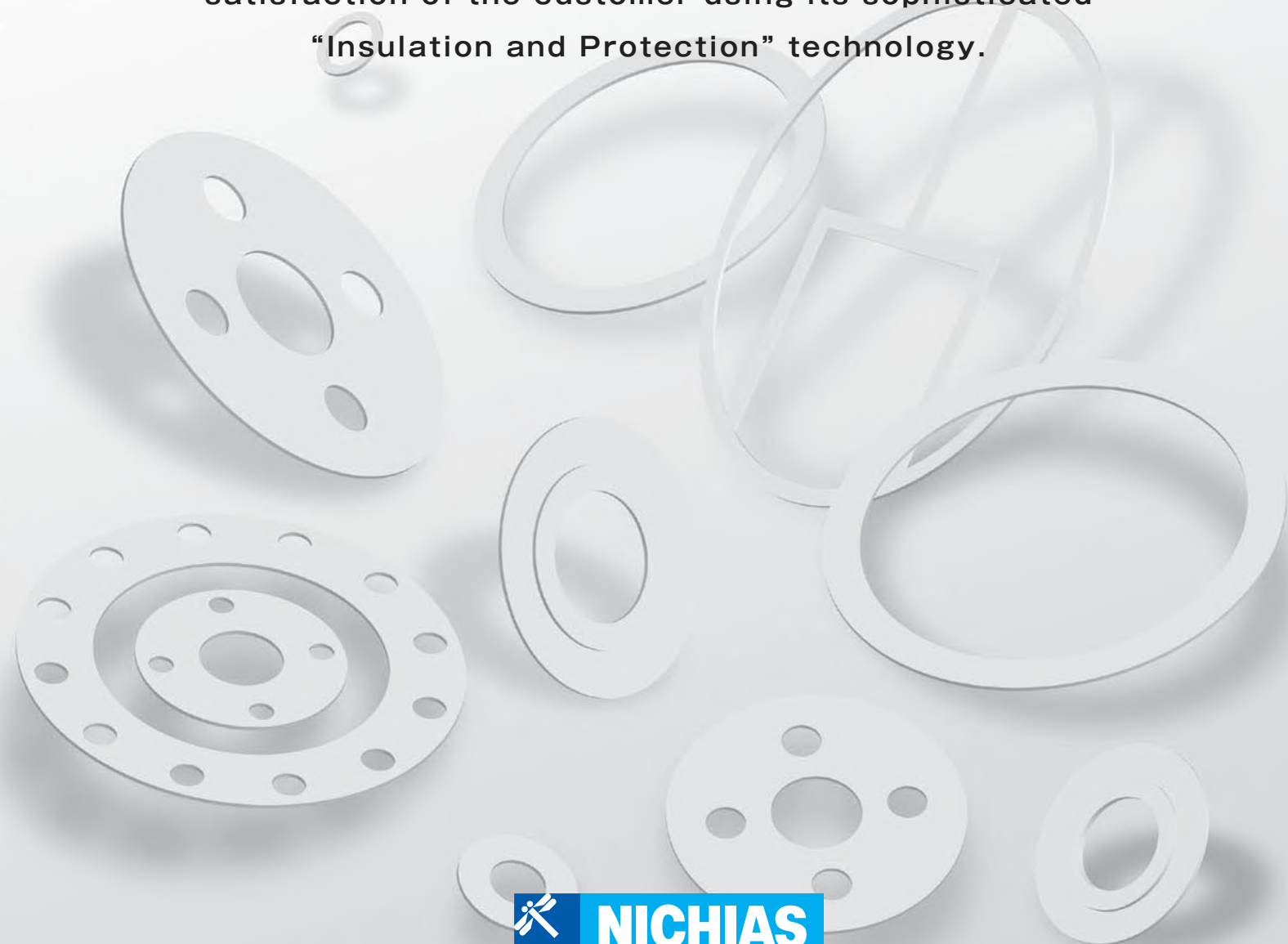

To ensure safe use

The physical properties, application selection, and other items indicated in this catalog are representative examples.

The performance data is based on the results on our test results and achievements in general applications. These products are used in various places and in various kinds of equipment. Also, the actual conditions of use differ from one product to another. For these reasons, it is recommended that before using a gasket, a confirmatory test be carried out under the actual conditions of use.

Regarding individual applications, it is necessary to judge the selection after carrying out an evaluation of individual design and compatibility. Regarding special applications, please contact Nichias.

Please observe the following items in order to maintain the intrinsic functions of the products in this catalog and also ensure that these products are used safely.

- 1) Do not use a product for any other than the purpose described in this catalog.
- 2) When it is necessary to shape a product, use a tool that has a fine cutting edge.
- 3) When combining a product with a pipe or a piece of equipment, be sure to follow the instruction manual for the product concerned.
- 4) During repair, for example, if an old product remains at the location where it was installed, completely remove the old product before installing a new one.
- 5) Check the precautions for occupational health using the MSDS (product safety data sheet).

— Precautions for handling fluororesin products —

- 1) Do not use a product in a human organ transplant and also do not bring a product into contact with bodily fluids or human tissue.
- 2) Do not use a product in an environment such that the maximum service temperature indicated in the catalog is exceeded.
- 3) If a product is exposed to a temperature that exceeds the maximum service temperature (continuous) indicated in the catalog, harmful gas may be generated. If such a condition occurs, adequately ventilate the area and be careful not to inhale the gas.

■ Storing gaskets

Store gaskets in a clean, cool and dark room. If they are stored in a place where they are exposed to direct sunlight, ozone, high temperature, high humidity, or a corrosive environment, the materials of the gaskets will deteriorate.

Store gaskets horizontally on shelves, leaving them packed in order to prevent lodgment of dirt, and so on. Also, place a cushioning sheet between the gaskets.

Do not suspend a gasket from a hook, or store it with a heavy object placed on it, because this may cause the gasket to break.

■ Handling gaskets

When handling a gasket, avoid the following behavior because this will lead to deformation or deterioration of the sealing performance.

- Do not throw a gasket, tread on it, pull it, bend it, fold it, rub two gaskets together, hold a large diameter gasket in one hand, or shake a gasket while holding it.

■ Disposing of gaskets

Dispose of used gaskets and scraps generated by shaping them in a dedicated disposal container and store and dispose of them separately from other items.

When disposing of such items, observe the related laws and regulations in your area. Do not incinerate these items. Note, however, that they can be incinerated using incinerating facilities that have suitable treatment equipment.

The contents of this catalog may be changed without prior notice.

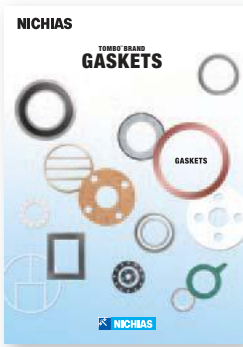

Concerning the use of this catalog

- *TOMBO is a registered trademark or trademark of Nichias Corporation.
- *Never-Seez is a trademark of Bostik Inc.
- *SGM is a trademark of W. L. Gore & Associates, Inc.
- *JPI:The Japan Petroleum Institute
- ASTM:American International, formerly known as the American Society for Testing and Materials

POINT

The four methods are available for selecting a gasket.

1
Searching for a gasket from a product group or product name

2
Searching for a gasket from a product number

3
Searching for a gasket from a type of fluid system

4
Searching for a gasket from the service temperature and pressure

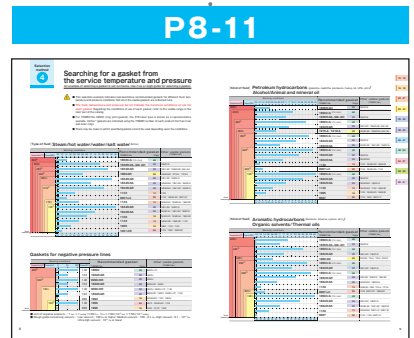
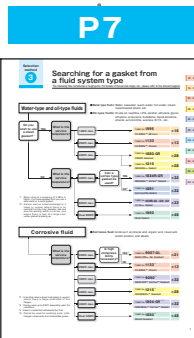
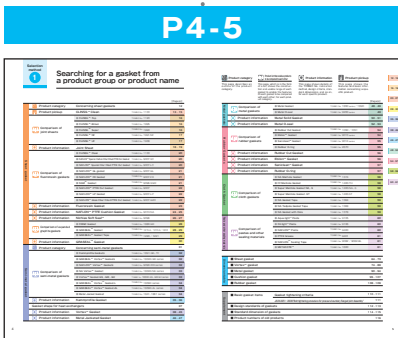

POINT

How to use this catalog



Product category

This page describes an outline of the product category.



Product list that enables products to be compared to each other

This page, which is in the form of a list, shows the construction and usable range of each gasket to enable the features of each gasket to be compared with each other, for each product category.



Product information

This page shows details of the TOMBO No. indication method, design criteria, standard dimensions, and so on, for each specific product.



Product pickup

This page shows the features and basic information concerning a specific product.

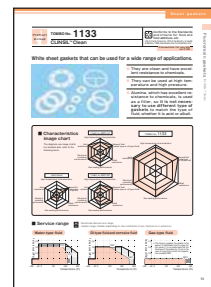
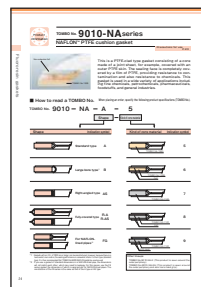
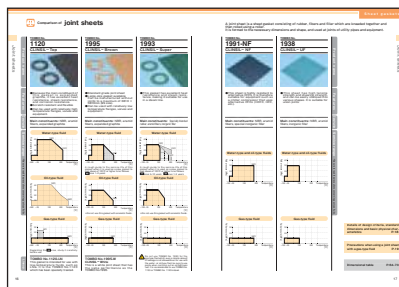
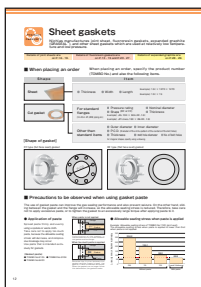















Plus

Dimension table and supplement

Searching for a gasket from a product group or product name

[Page(s)]

Sheet gasket	 Product category	Concerning sheet gaskets	12	
	 Product pickup	CLINSIL™ Clean	TOMBO No. 1133	
	 Comparison of joint sheets	● CLINSIL™ -Top	TOMBO No. 1120	16
		● CLINSIL™ -Brown	TOMBO No. 1995	16
		● CLINSIL™ Super	TOMBO No. 1993	16
		● CLINSIL™ NF	TOMBO No. 1991-NF	17
		● CLINSIL™ UF	TOMBO No. 1938	17
	 Product information	Joint Sheet	18 – 19	
	 Comparison of fluororesin gaskets	● CLINSIL™ Clean	TOMBO No. 1133	20
		● NAFLON™ Special Carbon Filler Filled PTFE Cut Gasket	TOMBO No. 9007-SC	20
		● NAFLON™ Special Filler Filled PTFE Cut Gasket	TOMBO No. 9007-LC	20
		● NAFLON™ GL gasket	TOMBO No. 9007-GL	21
		● NAFLON™ FD Gasket	TOMBO No. 9007-FD	21
		● SGM™ Gasket	TOMBO No. 9096-SGM	21
		● NAFLON™ PTFE Cut Gasket	TOMBO No. 9007	22
		● NAFLON™ LP Gasket	TOMBO No. 9007-LP	22
		● NAFLON™ Glass Fiber Filled PTFE Cut Gasket	TOMBO No. 9007-G20	22
	 Product information	Fluororesin Gasket	23	
	 Product information	NAFLON™ PTFE Cushion Gasket	TOMBO No. 9010-NA	24 – 25
	 Product information	Nichias Soft Seal™	TOMBO No. 9096	26 – 27
	 Comparison of expanded graphite gaskets	● CMGC Gasket	TOMBO No. 1880-GR	28
		● GRASEAL™ Gasket	TOMBO No. 1215-A / 1210-A / 1200	28 – 29
		● GRASEAL™ Gasket Tape	TOMBO No. 1220 / 1221	29
 Product information	GRASEAL™ Gasket	30		
Semi-metal gasket	 Product category	Concerning semi-metal gaskets	31	
	 Comparison of semi-metal gaskets	● Kamprofile Gaskets	TOMBO No. 1891-GR,-TF	32
		● GRASEAL™ Vortex™ Gaskets	TOMBO No. 1834R-GR series	32
		● NAFLON™ Vortex™ Gaskets	TOMBO No. 9090-IOR series	32
		● NA Vortex™ Gasket	TOMBO No. 1834R-NA series	33
		● Vortex™ Gasket-GS, -GM, -GH	TOMBO No. 1836R-GS,-GM-GH series	33
		● GRASEAL™ Vortex™ Gasket-L	TOMBO No. 1839R series	34
		● GRASEAL™ Vortex™ Gasket-AL	TOMBO No. 1839R-AL series	34
		● Metal Jacket Gasket	TOMBO No. 1841, 1861 series	34
	 Product information	Kamprofile Gasket	35 – 36	
	Gasket shape for heat exchangers		37	
	 Product information	Vortex™ Gasket	38 – 45	
	 Product information	Metal Jacketed Gasket	46 – 47	



Product category

This page describes an outline of the product category.



Product list that enables products to be compared to each other

This page, which is in the form of a list, shows the construction and usable range of each gasket to enable the features of each gasket to be compared with each other, for each product category.



Product information

This page shows details of the TOMBO No. indication method, design criteria, standard dimensions, and so on, for each specific product.



Product pickup

This page shows the features and basic information concerning a specific product.

12 – 15

16 – 19

20 – 27

28 – 30

35 – 36

38 – 45

46 – 47

48 – 53

54 – 57

58 – 59

60 – 61

[Page(s)]

Metal gaskets	Comparison of metal gaskets	● Metal Gasket	TOMBO No. 1850 series / 1890	48 – 49
		● Metal O-seal	TOMBO No. 9200 series	49
	Product information	Metal Solid Gasket		50 – 51
	Product information	Metal O-seal		52 – 53
Rubber Gaskets	Comparison of rubber gaskets	● Rubber Cut Gasket	TOMBO No. 1050 / 1051	54
		● Ebilon™ Gasket	TOMBO No. 9013 series	54
		● Saniclean™ Gasket	TOMBO No. 9014 series	55
		● Rubber O-ring	TOMBO No. 2670	55
	Product information	Rubber Cut Gasket		56
	Product information	Ebilon™ Gasket		56
	Product information	Saniclean™ Gasket		57
	Product information	Rubber O-ring		57
Cloth Gasket	Comparison of cloth gaskets	● NA Manhole Gasket	TOMBO No. 1374	58
		● FF Manhole Gasket	TOMBO No. 1400-TH	58
		● Super Manhole Gasket NA, -S	TOMBO No. 1400-NA, -S	58
		● Super Manhole Gasket -ST	TOMBO No. 1400-ST	58
		● NA Gasket Tape	TOMBO No. 1364	59
		● NA Tadpole Gasket Tape	TOMBO No. 1368	59
		● NA Gasket with Core	TOMBO No. 1378	59
		Paste and other sealing materials	Comparison of pastes and other sealing materials	● Aqua-tight™ Paste
● Oil-tight™ Paste	TOMBO No. 9106			60
● NAFLON™ Paste	TOMBO No. 9400			60
● PTFE Grease	TOMBO No. 9401			61
● NAFLON™ Sealing Tape	TOMBO No. 9082 / 9082-BL			61
● METAKOTE™	TOMBO No. 1600			61

Dimension table	■ Sheet gasket	64 – 73
	■ Vortex™ gasket	74 – 89
	■ Metal gasket	90 – 94
	■ Cushion gasket	95 – 107
	■ Rubber gasket	108 – 109

Supplement	■ Basic gasket items	Gasket tightening criteria	110 – 111
		JIS B 2251 : 2008 "Bolt tightening procedure for pressure boundary flanged joint Assembly"	111
	■ Design standards of gaskets		112 – 113
	■ Standard dimension of gaskets		114 – 115
	■ Product numbers of old products		116

Searching for a gasket from a product number (TOMBO No.)

Product number (TOMBO No.)	Product number	Page(s)
1050	Rubber Cut Gasket	54
1051	Rubber Cut Gasket	54
1120	CLINSIL™ -Top	16
1133	CLINSIL™ Clean	13-15
1200	GRASEAL™ Gasket	29
1210	GRASEAL™ Gasket	28
1215	GRASEAL™ Gasket	28
1220	GRASEAL™ Gasket Tape	29
1221	GRASEAL™ Gasket Tape	29
1364	NA Gasket Tape	59
1368	NA Tadpole Gasket Tape	59
1374	NA Manhole Gasket	58
1378	NA Gasket with Core	59
1400-NA	Super Manhole Gasket-NA	58
1400-S	Super Manhole Gasket-S	58
1400-ST	Super Manhole Gasket-ST	58
1400-TH	FF Manhole Gasket	58
1600	METAKOTE™	61
1834R-GR series	GRASEAL™ Vortex™ Gasket	32
1834R-NA series	NA Vortex™ Gasket	33
1836R-GH series	Vortex™ Gasket-GH	33
1836R-GM series	Vortex™ Gasket-GM	33
1836R-GS series	Vortex™ Gasket-GS	33
1839R-AL series	GRASEAL™ Vortex™ Gasket-AL	34
1839R series	GRASEAL™ Vortex™ Gasket-L	34
1841 series	Metal Jacketed Gasket	34
1861 series	Metal Jacketed Gasket	34
1850 series	Metal Gasket	48
1890	Metal Gasket	49
1880-GR	CMGC gasket	28

Product number (TOMBO No.)	Product number	Page(s)
1891-GR	Kammprofile Gasket	32
1891-TF	Kammprofile Gasket	32
1938	CLINSIL™ UF	17
1991-NF	CLINSIL™ NF	17
1993	CLINSIL™ -Super	16
1995	CLINSIL™ -Brown	16
2670	Rubber O-ring	55
9007	NAFLON™ PTFE Cut Gasket	22
9007-FD	NAFLON™ FD Gasket	21
9007-G20	NAFLON™ Glass Fiber Filled PTFE Cut Gasket	22
9007-GL	NAFLON™ GL Gasket	21
9007-LC	NAFLON™ Special Filler Filled PTFE Cut Gasket	20
9007-LP	NAFLON™ LP Gasket	22
9007-SC	NAFLON™ Special Carbon Filler Filled PTFE Cut Gasket	20
9010-NA	NAFLON™ PTFE Cushion Gasket	24-25
9013	Ebilon™ Gasket	54
9014	Saniclean™ Gasket	55
9082-BL	NAFLON™ Sealing Tape	61
9090-IOR series	NAFLON™ Vortex™ Gasket	32
9096	NICHIAS Soft Seal™	26-27
9096-SGM	SGM™ Gasket	21
9105	Aqua-tight™ Paste	60
9106	Oil-tight™ Paste	60
9200	Metal O-seal	52-53
9400	NAFLON™ Paste	60
9401	PTFE Grease	61
—	Irregular-shape Vortex™ Gasket	39
—	Heat Exchanger Vortex™ Gasket with Pass Ribs	39
—	Metal Jacketed Gasket with GRASEAL™ Tape	46
—	Metal Jacketed Heat Exchanger Gasket	46

Searching for a gasket from a fluid system type

The following flow constitutes a rough guide. For details of the service range, etc., please refer to the relevant page(s).

12 - 15

16 - 19

20 - 27

28 - 30

35 - 36

38 - 45

46 - 47

48 - 53

54 - 57

58 - 59

60 - 61

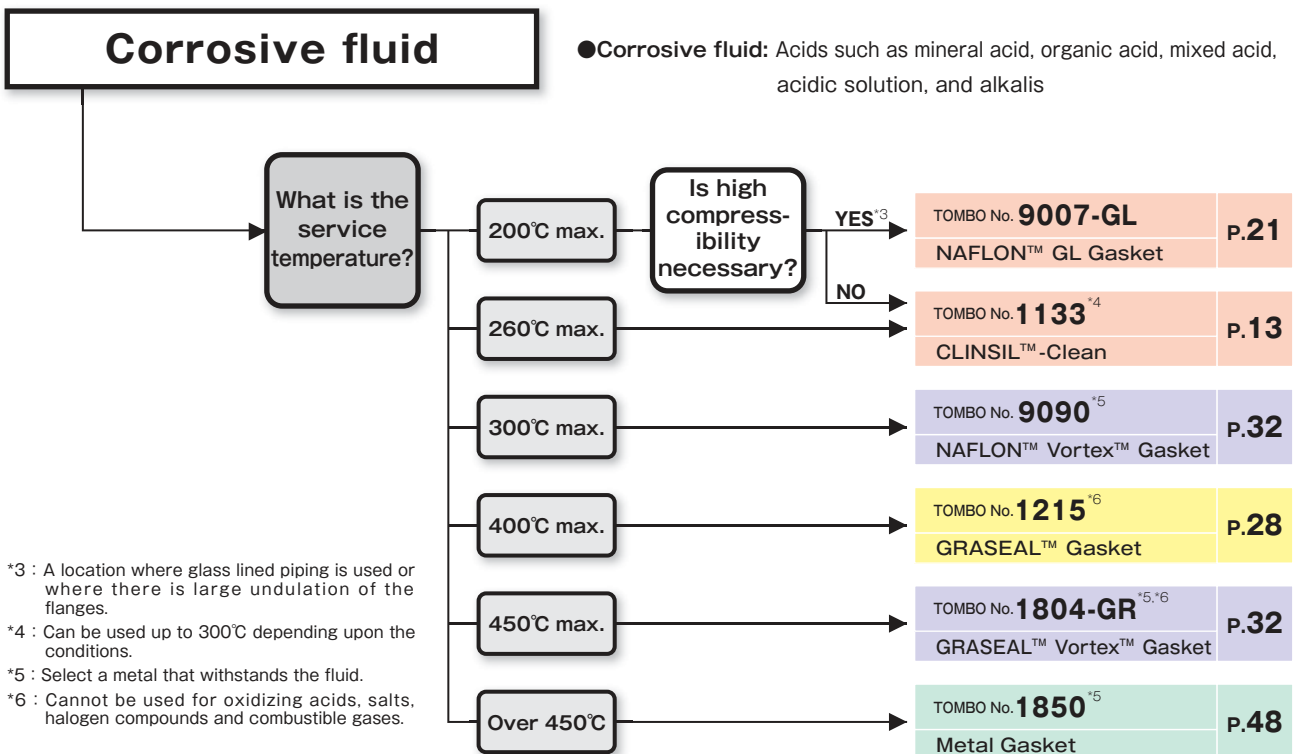
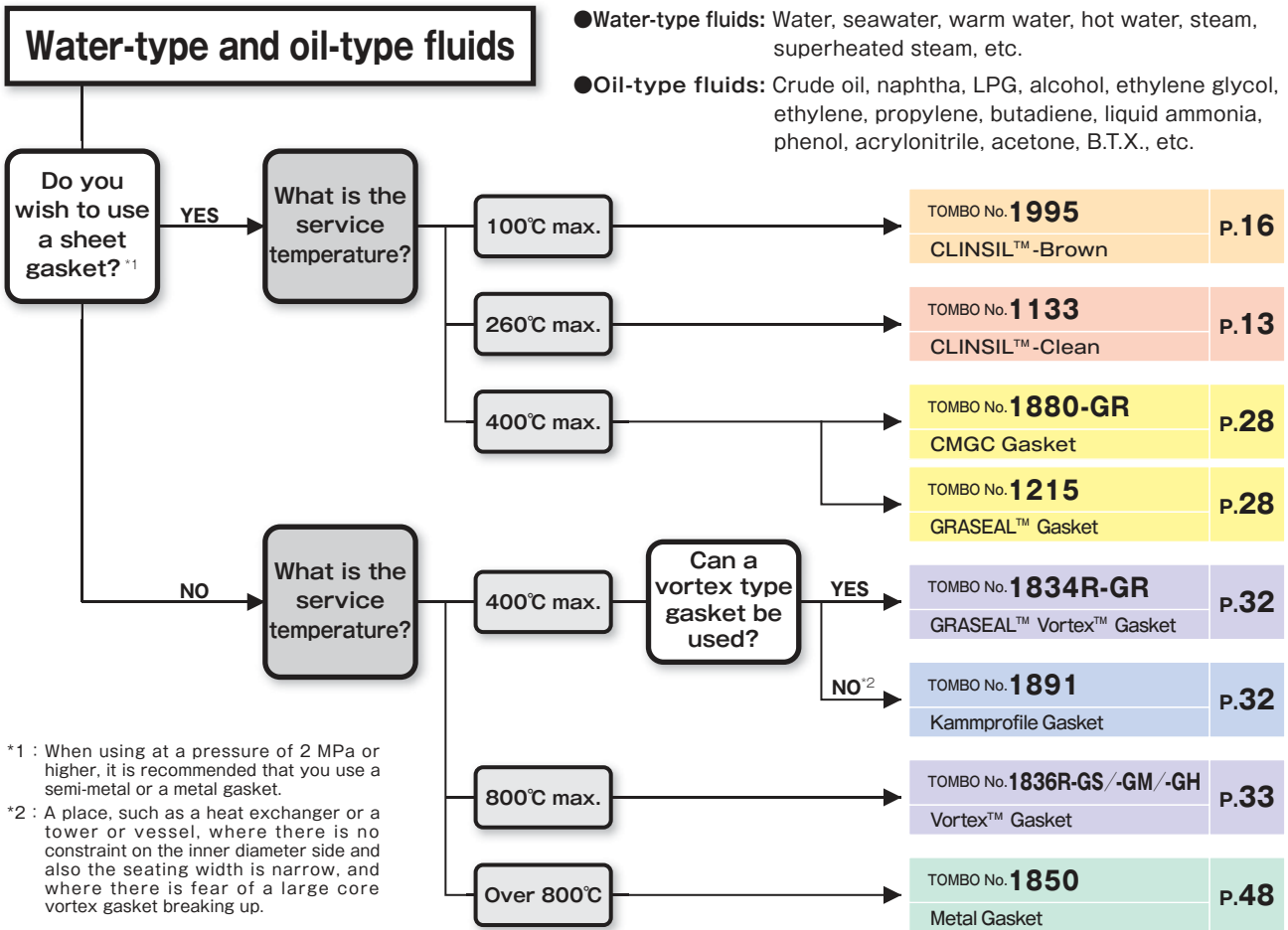

Searching for a gasket from the service temperature and pressure

An example of selecting a gasket is set out below. Use it as a rough guide for selecting a gasket.



- This selection example indicates representative recommended gaskets for different fluid, temperature and pressure conditions. Not all of the usable gaskets are indicated here.
- **The fluid, temperature and pressure do not indicate the maximum conditions of use for each gasket.** Regarding the conditions of use of each gasket, refer to the usable range in the main text of the catalog.
- For TOMBO No.1850C (ring joint gasket), the 316 steel type is shown as a representative example. Vortex™ gaskets are indicated using the TOMBO number of each product that has inner and outer rings.
- There may be cases in which specified gaskets cannot be used depending upon the conditions.

[Type of fluid] **Steam/hot water/water/salt water** (brine)

Temperature[°C]	Working conditions															Recommended gasket		Other usable gaskets (TOMBO No.)	
	Pressure[MPa]	0.5	1.0	1.5	1.8	2.0	3.0	3.6	4.0	12	16	18	20	29	34	44	TOMBO No.		Page
800°C																	1850C-G (316 steel)	48	
600°C																	1836R-GS, -GM, -GH	33	1850C-G
450°C																	1834R-GR	32	1891-GR / 1836R-GS, -GM, -GH
400°C																	1880-GR	28	1834R-GR / 1215-A / 1210-A
350°C																	1834R-GR	32	1891-GR / 1850C-G
350°C																	1834R-NA	33	1834R-GR / 1891-GR / 1850C-G
215°C																	1834R-GR	32	1834R-NA / 1891-GR / 1850C-G
215°C																	1133	13	1120
215°C																	9007-LC	20	1133 / 1834R-GR / 9007-SC
175°C																	1133	13	1834R-GR / 1834R-NA / 1880-GR
100°C																	1834R-GR	32	1891-GR / 1850C-G
100°C																	1834R-NA	33	1834R-NA / 1891-GR / 1850C-G
100°C																	1120	16	1834R-GR / 1834R-NA / 1880-GR
100°C																	1133	13	1834R-GR / 1880-GR / 1120
100°C																	1995	16	1880 / 1133 / 1120
Normal temperature																	1051-CR	54	1133 / 1995 / 1880-GR

Gaskets for negative pressure lines

Temperature[°C]	Working conditions				Recommended gasket		Other usable gaskets (TOMBO No.)	
	Pressure[torr]	5	0.1	0.01	Pressure[Pa]	TOMBO No.		Page
400°C					1.33	1850V	48	9200V-JTF
400°C					13.3	1834R-GR	32	1850V
300°C					1.33	9090-IOR	32	1850V
300°C					13.3	1834R-GR	32	9090-IOR / 1850V
150°C					1.33	9090-IOR	32	1850V / 9200V-JTF / 1133
150°C					13.3	1834R-GR	32	9090-IOR / 1850V / 9200V-JTF / 1133
100°C					666	1993	16	1834R-GR / 1133 / 1850V
100°C					1.33	1050	54	2670 / 1834R-GR / 1133
Normal temperature					666	1995	16	1050 / 1215T / 1993

- Unit of negative pressure / 1 torr = 1 mmHg = 133 Pa, 1 Pa = 7.50 × 10⁻³ torr = 7.50 × 10⁻³ mmHg
- Rough guide concerning vacuum / Low vacuum : 100 Pa or higher, Medium vacuum : 100 - 0.1 Pa, High vacuum : 0.1 - 10⁻⁵ Pa, Ultra-high vacuum : 10⁻⁵ Pa or lower

[Kind of fluid] **Petroleum hydrocarbons** (gasoline, naphtha, kerosene, heavy oil, LPG, etc.)/
Alcohol/Animal and mineral oil

Working conditions		Recommended gasket		Other usable gaskets
Temperature[°C]	Pressure[MPa]	TOMBO No.	Page	(TOMBO No.)
800°C	0.5	1836R-GH	33	1850C-G
	1.0			
600°C	0.5	1850C-G (316 steel)	48	
	1.0			
450°C	0.5	1836R-GS,-GM,-GH	33	1850C-G
	1.0			
400°C	0.5	1850C-G (316 steel)	48	
	1.0			
350°C	0.5	1834R-GR	32	1891-GR / 1836R-GS,-GM,-GH
	1.0			
260°C	0.5	1215-A / 1210-A	28	1834R-GR / 1836R-GS,-GM,-GH
	1.0			
200°C	0.5	1850C-G (316 steel)	48	
	1.0			
100°C	0.5	1834R-GR	32	1850C-G
	1.0			
Normal temperature	0.5	1834R-NA	33	1834R-GR / 1891-GR / 1850C-G
	1.0			
Normal temperature	0.5	1133	13	1120 / 1834R-GR / 1880-GR
	1.0			
Normal temperature	0.5	9007-LC	20	1133 / 1834R-GR / 1120
	1.0			
Normal temperature	0.5	1850C-G (316 steel)	48	
	1.0			
Normal temperature	0.5	1834R-GR	32	1850C-G
	1.0			
Normal temperature	0.5	1834R-NA	33	1834R-GR / 1850C-G
	1.0			
Normal temperature	0.5	1133	13	1834R-GR / 1120 / 1880-GR
	1.0			
Normal temperature	0.5	1995	16	1120 / 1834R-GR / 1880-GR
	1.0			
Normal temperature	0.5	9007	22	1133 / 1995 / 9007-LP
	1.0			

[Kind of fluid] **Aromatic hydrocarbons** (benzene, toluene, xylene, etc.)/
Organic solvents/Thermal oils

Working conditions		Recommended gasket		Other usable gaskets
Temperature[°C]	Pressure[MPa]	TOMBO No.	Page	(TOMBO No.)
600°C	0.5	1850C-G (316 steel)	48	
	1.0			
450°C	0.5	1836R-GS,-GM,-GH	33	1850C-G
	1.0			
400°C	0.5	1850C-G (316 steel)	48	
	1.0			
350°C	0.5	1834R-GR	32	1891-GR / 1850C-G
	1.0			
260°C	0.5	1880-GR	28	1834R-GR / 1215-A / 1210-A / 1850C-G
	1.0			
200°C	0.5	1850C-G (316 steel)	48	
	1.0			
100°C	0.5	1834R-GR	32	1891-GR / 1850C-G
	1.0			
Normal temperature	0.5	1834R-NA	33	1834R-GR / 1850C-G
	1.0			
Normal temperature	0.5	1133	13	1834R-GR / 1880 / 1215-A / 1210-A
	1.0			
Normal temperature	0.5	9007-LC	20	1133 / 9007-SC / 1880-GR
	1.0			
Normal temperature	0.5	1850C-G (316 steel)	48	
	1.0			
Normal temperature	0.5	1834R-GR	32	1891-GR / 1850C-G
	1.0			
Normal temperature	0.5	1834R-NA	33	1834R-GR / 1891-GR / 1850C-G
	1.0			
Normal temperature	0.5	1133	13	1834R-GR / 9007-LC / 9007-SC
	1.0			
Normal temperature	0.5	9007	22	1133 / 1120 / 9007-LP
	1.0			

[Kind of fluid] **Weak acids** (acetic acid, carbonic acid, etc.)/**Weak alkalis** (ammonia, etc.)/**Saline**

Working conditions		Recommended gasket		Other usable gaskets
Temperature[°C]	Pressure[MPa]	TOMBO No.	Page	(TOMBO No.)
260°C	0.5	1834R-GR	32	1891-GR
	1.0			
	1.5			
	1.8			
200°C	3.0	1215-A / 1210-A	28	1834R-GR / 1891-GR
	4.6			
	9.0			
100°C	0.5	1133	13	1880-GR / 1215-A / 1210-A / 1120
	1.0			
	1.5			
	1.8			
Normal temperature	3.0	9007-LC	20	1133 / 1834R-GR
	4.6			
	9.0			
260°C	0.5	1834R-GR	32	
	1.0			
	1.5			
	1.8			
200°C	3.0	1133	13	1834R-GR / 1215-A / 1210-A
	4.6			
	9.0			
100°C	0.5	1995	16	1133 / 1880-GR / 1120
	1.0			
	1.5			
	1.8			
Normal temperature	3.0	9007	22	1133 / 1880-GR / 1120
	4.6			
	9.0			

[Kind of fluid] **Strong acids** (sulfuric acid, hydrochloric acid, nitric acid, etc.)

Working conditions		Recommended gasket		Other usable gaskets
Temperature[°C]	Pressure[MPa]	TOMBO No.	Page	(TOMBO No.)
260°C	0.5	9090-IOR ^{*1}	32	
	1.0			
	1.5			
	1.8			
200°C	3.0	1133	13	9090-IOR
	4.6			
	9.0			
100°C	0.5	9007-LC	20	1133 / 9090-IOR
	1.0			
	1.5			
	1.8			
Normal temperature	3.0	9090-IOR ^{*1}	32	
	4.6			
	9.0			
260°C	0.5	1133	13	9090-IOR
	1.0			
	1.5			
	1.8			
200°C	3.0	9007-LC	20	1133 / 9090-IOR
	4.6			
	9.0			
100°C	0.5	9007	22	1133 / 9090-IOR
	1.0			
	1.5			
	1.8			
Normal temperature	3.0			
	4.6			
	9.0			

*1 : Select a metal that withstands the fluid.

[Kind of fluid] **Strong alkalis** (caustic soda, caustic potash, etc.)

Working conditions		Recommended gasket		Other usable gaskets
Temperature[°C]	Pressure[MPa]	TOMBO No.	Page	(TOMBO No.)
260°C	0.5	1834R-GR	32	1891-GR
	1.5			
	1.8			
	3.0			
200°C	4.6	1215-A / 1210-A	28	1834R-GR / 1891-GR / 1880-GR
	9.0			
	11			
120°C	0.5	9007-SC	20	1834R-GR / 1880-GR / 1215-A / 1210-A
	1.5			
	1.8			
	3.0			
100°C	4.6	1133 ^{*2}	13	1834R-GR / 9007-SC / 1215-A / 1210-A
	9.0			
	11			
260°C	0.5	1834R-GR	32	1834R-NA
	1.5			
	1.8			
	3.0			
200°C	4.6	1133	13	1834R-GR / 1834R-NA / 1215-A / 1210-A
	9.0			
	11			
100°C	0.5	9007-SC	20	1133 / 1834R-GR / 1120
	1.5			
	1.8			
	3.0			
Normal temperature	4.6	9007	22	1133 / 1834R-GR / 9007-SC
	9.0			
	11			

*2 : Use at a fluid concentration of no more than 30%.

[Kind of fluid] **Air**

Working conditions		Recommended gasket		Other usable gaskets
Temperature[°C]	Pressure[MPa]	TOMBO No.	Page	(TOMBO No.)
600°C	0.3	1841-FI-G ^{*3}	34	
	0.5			
	1.0			
	1.5			
300°C	5.0	1834R-GR	32	1841-FI-G / 1891-GR / 1850C-G
	0.3			
	0.5			
260°C	1.0	1133	13	1834R-GR / 1880-GR / 1120
	1.5			
	5.0			
	0.3			
200°C	0.5	9007-LC	20	1133 / 1880-GR / 1120
	1.0			
	1.5			
100°C	0.3	1995 ^{*3}	16	1133 / 1834R-GR / 1050 series
	0.5			
	1.0			
	1.5			
Normal temperature	5.0	9007	22	1133 / 1834R-GR / 1995
	0.3			
	0.5			

*3 : Use gasket paste.

[Kind of fluid] Exhaust gas

Working conditions		Recommended gasket		Other usable gaskets
Temperature[°C]	Pressure[MPa]	TOMBO No.	Page	(TOMBO No.)
700°C	0.01 - 1.0	1400-ST ^{*4}	58	1400-S ^{*4}
500°C	0.01 - 1.0	1400-TH ^{*4}	58	1400-ST ^{*4} / 1400-S ^{*4} / 1400-NA ^{*4}
300°C	0.01 - 1.0	1374 ^{*4}	58	1400-ST ^{*4} / 1400-TH ^{*4} / 1400-NA ^{*4}
260°C	0.01 - 1.0	1133	13	
200°C	0.01 - 1.0	1120	16	1133 / 1834R-GR
100°C	0.01 - 1.0	1995	16	1133 / 1834R-GR / 1120

*4 : Use at locations where a certain amount of leakage is tolerated.

[Kind of fluid] Combustible gas/Toxic gas/Hydrogen gas/Ammonia

Working conditions		Recommended gasket		Other usable gaskets
Temperature[°C]	Pressure[MPa]	TOMBO No.	Page	(TOMBO No.)
600°C	0.5 - 39	1850C-G (316 steel)	48	
450°C	0.5 - 39	1850C-G (316 steel)	48	
350°C	0.5 - 39	1834R-GR	32	1891-GR / 1850C-G
350°C	0.5 - 39	1850C-G (316 steel)	48	
350°C	0.5 - 39	1834R-GR	32	1891-GR / 1850C-G
260°C	0.5 - 39	1834R-NA	33	1834R-GR / 1891-GR / 1850C-G
260°C	0.5 - 39	1850C-G (316 steel)	48	
260°C	0.5 - 39	1834R-GR	32	1891-GR / 1850C-G
260°C	0.5 - 39	9090-IOR	32	1834R-GR / 1891-GR / 1850C-G
260°C	0.5 - 39	1834R-NA	33	1834R-GR / 9090-IOR / 1891-GR
200°C	0.5 - 39	1133	13	1834R-GR / 9090-IOR / 1834R-NA
200°C	0.5 - 39	9007-LC	20	1133 / 1834R-GR / 9090-IOR
100°C	0.5 - 39	9007	22	1133 / 1834R-GR / 9007-LP

[Kind of fluid] Oxygen gas/Low-temperature fluid/Liquefied gas/ LNG/LN₂/LO₂/Ethylene

Working conditions		Recommended gasket		Other usable gaskets
Temperature[°C]	Pressure[MPa]	TOMBO No.	Page	(TOMBO No.)
260°C	1.0 - 39	1850C-G (316 steel)	48	
260°C	1.0 - 39	9090-IOR-OX	32	1834R-GR
100°C	1.0 - 39	1133	13	1834R-GR / 9007-LC / 9090-IOR-OX
-200°C	1.0 - 39	1133	13	1120-LN / 1839R
-240°C	1.0 - 39	1834R-GR	32	
-240°C	1.0 - 39	1839R	34	



Sheet gaskets

Nichias manufactures joint sheet, fluororesin gaskets, expanded graphite (GRASEAL™), and other sheet gaskets which are used at relatively low temperature and low pressure.



Details of joint sheets are on P.16 - 19.

Details of fluororesin gaskets are on P.13 - 15 and P.20 - 27.

Details of expanded graphite are on P.28 - 29.

When placing an order

When placing an order, specify the product number (TOMBO No.) and also the following items.

Shape	Item
<p>Sheet</p> 	<ul style="list-style-type: none"> ● Thickness ● Width ● Length <p>Example) 1.5t × 1270 × 1270 Example) 1.5t × 1S</p>
<p>Cut gasket</p> 	<p>For standard flanges (for JIS or JPI (ANSI) piping, etc.)</p> <ul style="list-style-type: none"> ● Pressure rating ● Shape (RF or FF) ● Nominal diameter ● Thickness <p>Example) JIS.10K × 50A.RF.1.5t Example) JPI class.150 × 2B.RF.1.5t</p>
	<p>Other than standard items</p> <ul style="list-style-type: none"> ● Outer diameter ● Inner diameter ● P.C.D. (Diameter of the circle pattern of the centers of the bolt holes) ● Thickness ● Bolt hole diameter ● No. of bolt holes <p>For irregular shapes, specify using a drawing.</p>

[Shape of gasket]

FF type (full face seat) gasket

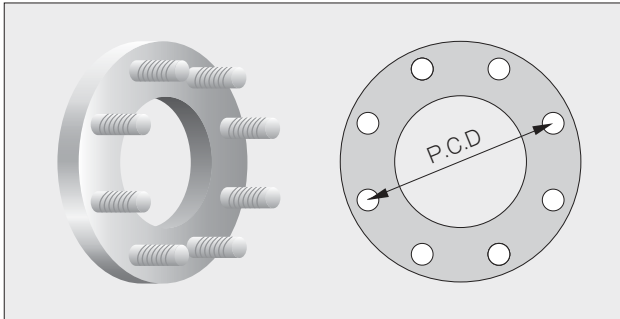

RF type (flat face seat) gasket

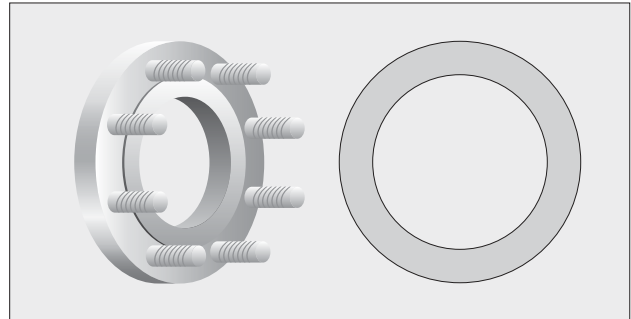

Precautions to be observed when using gasket paste

The use of gasket paste can improve the gas sealing performance and also prevent seizure. On the other hand, sliding between the gasket and the flange will increase, so the allowable seating stress is reduced. Therefore, take care not to apply excessive paste, or to tighten the gasket to an excessively large torque after applying paste to it.

● Application of paste

Spread paste thinly and evenly using a spatula or waste cloth. Take care not to apply too much paste, because the allowable seating stress will decrease, and compressive breakage may occur. Use paste that is intended exclusively for gaskets.

(Gasket paste)

- TOMBO No.9105
- TOMBO No.9106
- TOMBO No.9400

When paste is not applied

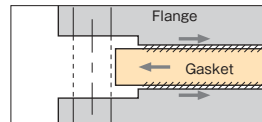

Deformation of the gasket is suppressed due to friction between the gasket and the flange.

When too much paste is applied

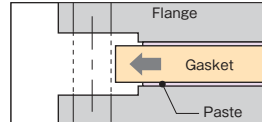

Because the friction between the gasket and the flange is small, the gasket is liable to become deformed. When the gasket can no longer follow this deformation, the gasket breaks.

● Allowable seating stress when paste is applied

Example: Allowable seating stress of TOMBO No.1120 (joint seat)
The allowable seating stress when paste is applied is lower than that when paste is not applied.

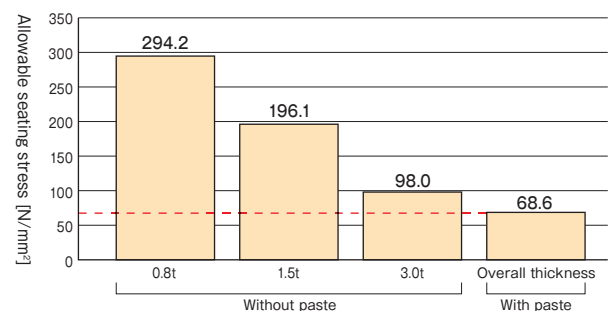



TOMBO No. 1133
CLINSIL™ Clean



Conforms to the Standards and criteria for food and food additives, etc.
 (3-D-2, Public Notice No. 370 of the Ministry of Health & Welfare, 1959) stipulated by the Food Sanitation Act

Precautions for use are on P.23.

White sheet gaskets that can be used for a wide range of applications.

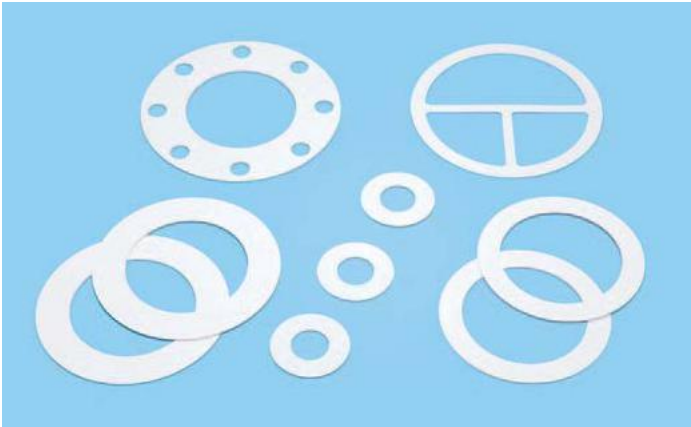

- They are clean and have excellent resistance to chemicals.
- They can be used at high temperature and high pressure.
- Alumina, which has excellent resistance to chemicals, is used as a filler, so it is not necessary to use different type of gaskets to match the type of fluid, whether it is acid or alkali.

Characteristics image chart

The diagrams are image charts. For detailed data, refer to the following items.

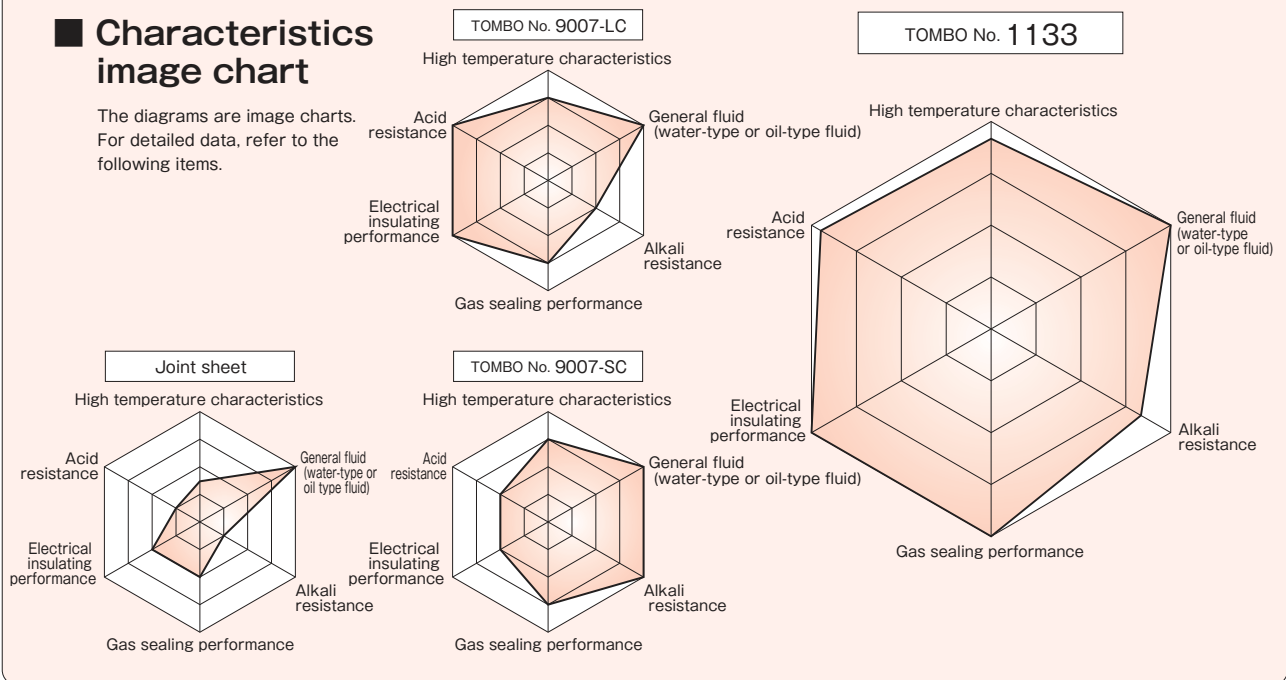

Service range

Recommended service range
 Usable range (Usable depending on the conditions of use. Consult us in advance.)

Water-type fluid

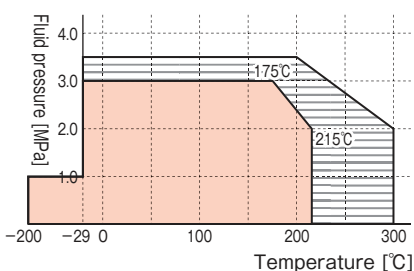

Oil-type fluid and corrosive fluid

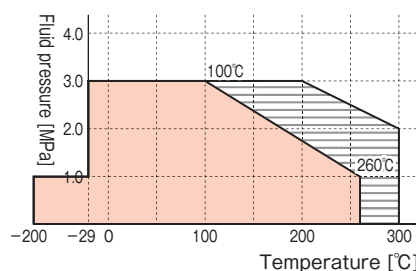

Gas-type fluid

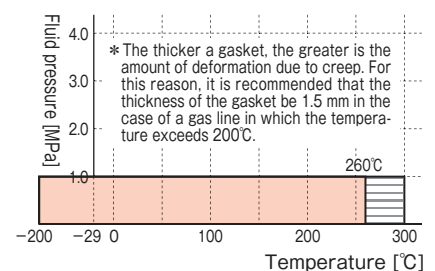

■ Design criteria

TOMBO No.		1133
Gasket factor m	[—]	
	1.0 t	3.50
	1.5 t	2.75
	2.0 t	2.75
Minimum designed seating stress y	[N/mm ²]	
	1.0 t	44.8
	1.5 t	25.5
	2.0 t	25.5
Minimum seating stress σ^3	[N/mm ²]	
	Water-type or oil-type fluid	14.7
Allowable seating stress	[N/mm ²]	
	Gas-type fluid	34.3
		150

■ Standard dimensions

TOMBO No.		1133
Maximum O.D.	[mm]	
	1.0 t	φ 610
	1.5 t	φ 1250
	2.0 t	φ 1430
Standard thickness		
	1.0 t	●
	1.5 t	●
	2.0 t	●
	3.0 t	●

* The yellow part in the table can be made larger by welding.

Chemical resistance test

Test method: Measure the weight change rate of TOMBO No.1133 and our conventional gasket after leaving them immersed in representative acid and alkali fluid for 7 days each.

Fluid	Concentration	Temperature	TOMBO No.			
			1133	9007-SC	9007-LC	
Acid	Hydrochloric acid	35%	50°C	A	A	A
	Nitric acid	95%	100°C	A	A	A
	Sulfuric acid	65%	100°C	A	Measurement impossible ^{*1}	A
	Hydrofluoric acid	55%	Room temperature	A	A	C
	Phosphoric acid	85%	100°C	A	A	A
Alkali	Sodium hydroxide	48%	100°C	A	A	C
	Potassium hydroxide	48%	100°C	A	A	B

*1: The test was interrupted because the filler reacted with the fluid and emitted smoke.

A ...Good chemical resistance. B ...Study must be carried out using actual machine. C ...Cannot be used.

TOMBO No.1133 has excellent resistance to chemicals, including acids and alkalis.

■ Examples of chemicals for which CLINSIL™ Clean is suitable

Acids	Alkalis	Halogens	Aromatics	Others
Hydrochloric acid	Potassium hydroxide ^{*1}	Chlorine gas	Benzene	Alcohols Dimethylform-amide
Sulfuric acid	Sodium hydroxide ^{*1}	Bromine	Toluene	Hydrocarbons Tetrahydrofuran
Nitric acid	Liquid ammonia		Xylene	Organic acid Diethylamin
Acetic acid			Nathphalene	Vinyl acetate monomer Acetoaldehyde
Phosphoric acid ^{*1}			Phenol	Styrene monomer Nitril liquid
Hydrofluoric acid			Cumene	Acrylonitrile Methyl chlorides
Formic acid				Saturated steam Etc.
Boric acid				Hexane

*1: Fluids for which care is necessary

Under the following conditions, the filler may liquate out and impair the performance of the gasket. For this reason, do not use this gasket under such conditions.

- For a sodium hydroxide water solution or potassium hydroxide water solution:
 - Fluid concentration is 30% or higher and fluid temperature is 100°C or higher
 - Fluid temperature is 120°C or higher
- In the case of phosphoric acid, when the temperature is at 100°C or higher.
- Chromic acid (hexavalent chrome)

*For other fluids, refer to the precautions for use.

Precautions for use are on P.23.

Gas seal test

Test method: Compress the gasket-sealed flanges filled with N₂ gas using a press, and measure the amount of leakage in terms of the reduction of pressure of the sealed gas.

[Test conditions]

- Gasket size: JIS 10K 50A FR (1.5t)
- Test jig: Platen that has the same dimensions as that used in JIS B 2490
- Tightening method: Press
- Seating stress: max. 34.3N/mm²
- Fluid: Nitrogen
- Internal pressure: 0.98MPa
- Leakage detection: Digital pressure gauge

[Test schematic drawing]

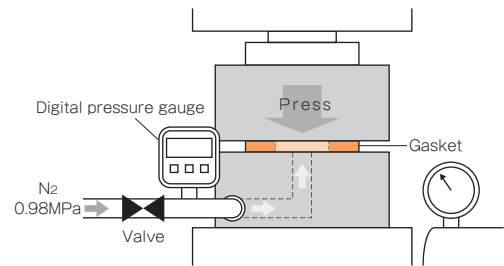

- ...TOMBO No.1133 (CLINSIL™ Clean)
- ...TOMBO No.9007-LC (NAFLON™ special filler filled PTFE cut gasket)
- △...TOMBO No.9007-SC (NAFLON™ special carbon filler filled PTFE cut gasket)
- Limit of leakage detection using soapy water foaming method (0.2ml/min)

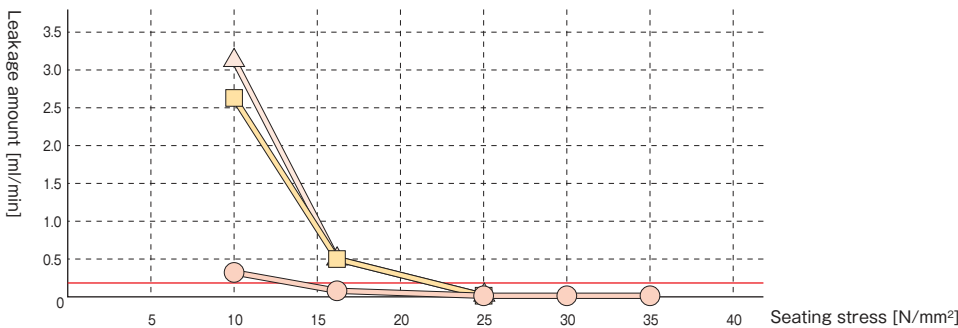

TOMBO No.1133 has excellent sealing performance, even when the seating stress is low.

Heat resistance test

Test method: Subject the gasket to a heat cycle under the following conditions, and carry out a sealing test for the specified number of cycles.

[Test conditions]

- Flange size: JIS 10K 25A RF
- Gasket thickness: 1.5mm
- Seating stress: 34.3N/mm²
- Heating conditions: 300°C × 15hr × 10 cycles
- Fluid: Nitrogen
- Internal pressure: 1.0MPa
- Sealing test method: Soapy water foaming method

[Test results]

Number of cycles	Leakage
0	None
1	None
3	None
5	None
10	None

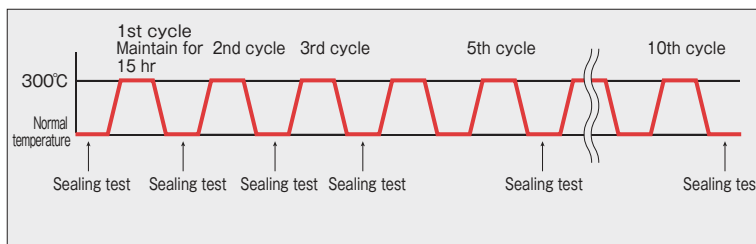

* Criterion for no leakage
Limit of detection using soapy water foaming method (0.2ml/min)

TOMBO No.1133 has excellent heat resistance.



Comparison of joint sheets

Product name

Features

Construction

Service range

*Be sure to read the precautions concerning gas-type fluids.

Lineup

TOMBO No.

1120

CLINSIL™ Top

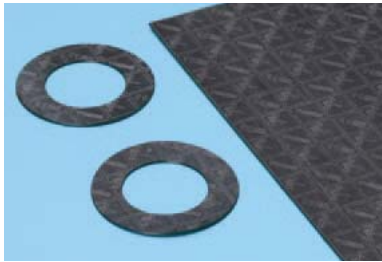

- Because the main constituent of this gasket is expanded graphite, it has excellent heat resistance, steam resistance, and corrosion resistance.
- Scratch resistant and flexible
- Can be used with relatively high temperature flanges, valves and equipment.

Main constituents: NBR, aramid fibers, expanded graphite

Water-type fluid

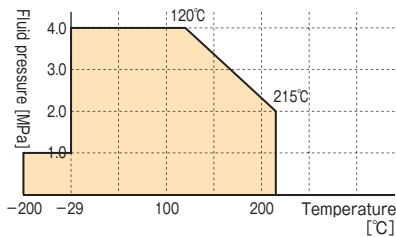

Oil-type fluid

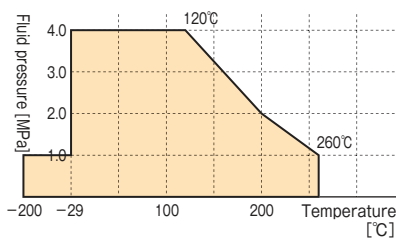

Gas-type fluid

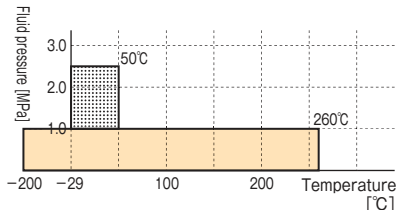

Regarding the shaded area, study it carefully before use.

TOMBO No. 1120-LN

This gasket is intended for use with low-temperature fluids, such as LNG. It is the TOMBO No. 1120 which has been specially treated.

TOMBO No.

1995

CLINSIL™ Brown

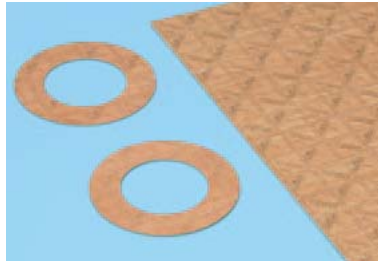

- Standard grade joint sheet
- Large-size gasket available
Can be manufactured without joints to a maximum of 3810 x 3810mm (9S size).
- Can be used with relatively low temperature flanges, valves and equipment.

Main constituents: NBR, aramid fibers, expanded graphite

Water-type fluid

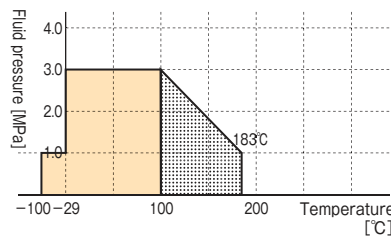

A rough guide to the service life of this gasket when it is used as a pipe gasket to seal steam of 100°C or higher is as follows.

■ area: 1-2 years

Oil-type fluid

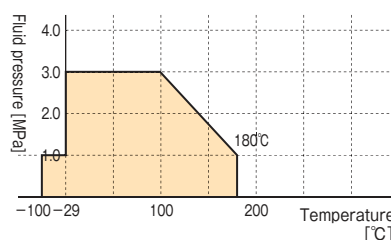

*Do not use this gasket with aromatic fluids.

Gas-type fluid

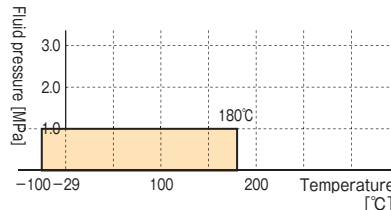

TOMBO No. 1995-W
CLINSIL™ White

This is a white joint sheet that has the same performance as the TOMBO No. 1995.

TOMBO No.

1993

CLINSIL™ Super

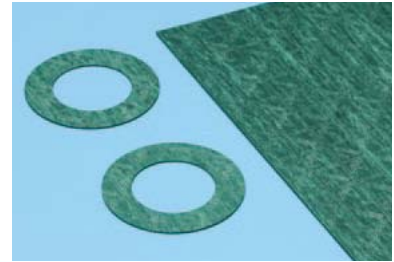

- This gasket has excellent heat resistance and steam resistance, making it suitable for use in a steam line.

Main constituents: Specially blended rubber, aramid fibers, inorganic filler

Water-type fluid

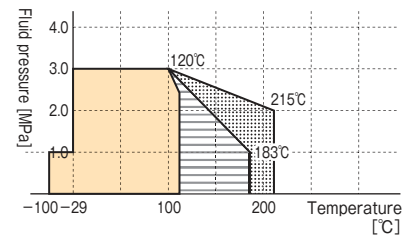

A rough guide to the service life of this gasket when it is used as a pipe gasket to seal steam of 100°C or higher is as follows.

■ area: 5-10 years ■ area: 1-2 years

Oil-type fluid

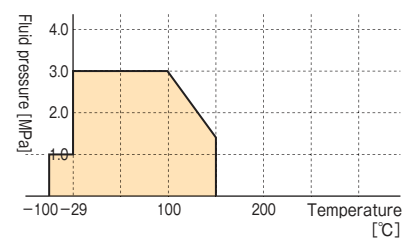

*Do not use this gasket with aromatic fluids.

Gas-type fluid

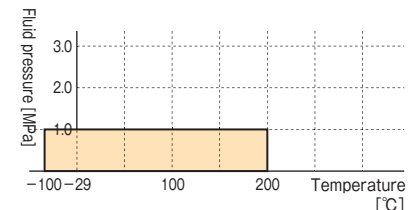

! Do not use TOMBO No. 1993 for the gas-type fluid which even a minute amount of leakage is not allowed. Even for use with the water- or oil-type fluid, be sure to use paste when carrying out an airtightness test. It is recommended to use TOMBO No. 1133 or TOMBO No. 1120 instead.

A joint sheet is a sheet gasket consisting of rubber, fibers and filler which are kneaded together and then rolled using a roller. It is formed to the necessary dimensions and shape, and used at joints of utility pipes and equipment.

TOMBO No.

1991-NF

CLINSIL™ NF

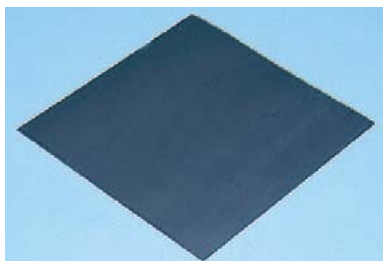

● This sheet is highly resistant to alternative CFCs. It is therefore suitable for equipment such as a chiller compressor that uses alternative CFCs (HCFC, HFC, etc.).

Main constituents: NBR, aramid fibers, special inorganic filler

Water-type and oil-type fluids

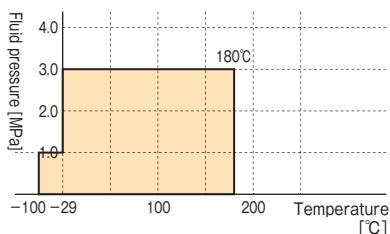

Gas-type fluid

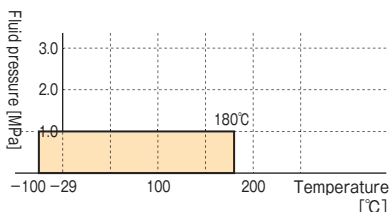

TOMBO No.

1938

CLINSIL™ UF

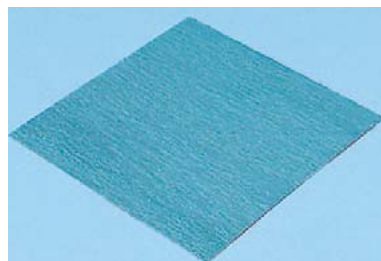

● This sheet has high tensile strength and shearing strength, and can be easily stamped into various shapes. It is suitable for union joints.

Main constituents: NBR, aramid fibers, inorganic filler

Water-type and oil-type fluids

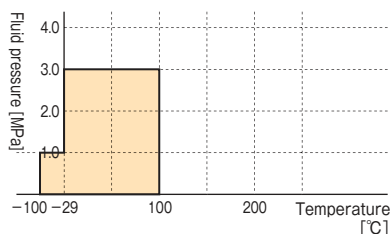

Gas-type fluid

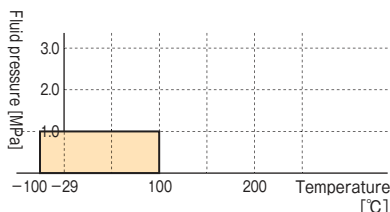

Product name

Features

Construction

Service range

*Be sure to read the precautions concerning gas-type fluids.

Details of design criteria, standard dimensions and basic physical characteristics P.18

Precautions when using a joint sheet with a gas-type fluid P.19

Dimensional table P.64-73



■ Design criteria

TOMBO No.		1120	1995	1993	
Gasket coefficient m [-]	0.8 t	3.50			
	1.5 t	2.75			
	3.0 t	2.00			
Minimum design seating stress y [N/mm ²]	0.8 t	44.8			
	1.5 t	25.5			
	3.0 t	11.0			
Minimum seating stress σ_3 [N/mm ²]	Water-type and oil-type fluids	14.7			
	Gas-type fluids	34.3 ^{*1}			
Allowable seating stress [N/mm ²]	Without paste	0.8 t	294.2		
		1.5 t	196.1		
		3.0 t	98.0	147.1	
	With paste	0.8 t	68.6 ^{*2}		
		1.5 t			
		3.0 t			

*1 : Use of gaskets with thickness of 3.0t for gas-type fluid is not recommended.

*2 : 58.8N/mm² when anti-corrosion paste is used.

■ Standard dimensions

TOMBO No.		1120	1995	1993	1991-NF	1938
1S (1270×1270mm)	0.4 t	●	—	—	●	—
	0.5 t	●	—	●	●	—
	0.8 t	●	●	●	●	—
	1.0 t	●	●	●	●	●
	1.5 t	●	●	●	●	●
	2.0 t	●	●	●	—	●
	3.0 t	●	●	●	—	—
3S (1270×3810mm)	0.4 t	●	—	—	●	—
	0.5 t	●	—	●	●	—
	0.8 t	●	●	●	●	—
	1.0 t	●	●	●	●	—
	1.5 t	●	●	●	●	—
	2.0 t	●	●	●	—	—
	3.0 t	●	●	●	—	—
6S (2540×3810mm)	0.8t	●	●	—	—	—
	1.0 t	●	●	—	—	—
	1.5 t	●	●	—	—	—
	2.0 t	●	●	—	—	—
	3.0 t	●	●	—	—	—
9S (3810×3810mm)	0.8 t	—	●	—	—	—
	1.0 t	—	●	—	—	—
	1.5 t	—	●	—	—	—
	2.0 t	—	●	—	—	—
	3.0 t	—	●	—	—	—
Weight [kg] per sheet of thickness 1.5t and 1S size (reference)		3.63	4.35	4.23	3.75	4.35

* The above are standard dimensions. We can also manufacture some sheets that are not marked ●. For details, please contact us.

■ Basic physical properties

TOMBO No.		1120	1995	1993	1991-NF	1938	
Sample thickness [mm]		1.5	1.5	1.5	1.0	1.5	
Tensile strength [N/mm ²]		27.5	24.1	14.7	26.2	21.6	
Compression ratio [%]	34.3N/mm ²	9	7	7	6	7	
Recovery [%]		70	65	52	67	55	
Oil resistance	IRM903 oil 150°C×5h	Thickness increase ratio [%]	2	3	24	1	1
		Tensile strength reduction ratio [%]	11	23	33	-1	0
	IRM903 oil 40°C×48h	Thickness increase ratio [%]	—	4	—	1	—
		Tensile strength reduction ratio [%]	—	4	—	6	—
		Compression ratio [%]	—	6	—	6	—
		Recovery [%]	—	64	—	73	—
Resistance to fuel oil	ASTM Fuel B (JIS fuel oil B) R.T.×5h	Thickness increase ratio [%]	2	4	18	3	3
		Mass increase ratio [%]	1	6	17	5	4
Stress relaxation ratio [%]		25	28	20	15	26	
Density [g/cm ³]		1.53	1.84	1.71	1.62	1.80	

* The above values are measured values. They are not standard values.

⚠️ Precautions concerning joint sheets

■ Precautions concerning design and selection

● Finish of the gasket seat

The recommended surface roughness when using a joint sheet is as follows.

- For sealing liquid : $6.3\ \mu\text{m Ra}$
- For sealing gas : $3.2\ \mu\text{m Ra}$

● Recommended thickness and shape of gasket

The recommended thickness and shape of joint sheets are basically as follows.

Fluid	Nominal diameter	Thickness	Shape
Water-type and oil-type	150A (6B) max	1.5mm	—
	200A (8B) min	3.0mm	—
Gas-type	All sizes	1.5mm min ^{*2}	Ring-shaped ^{*3}
Steam and hot water lines ^{*1}	All sizes	1.5mm	Ring-shaped ^{*3}

*1 : Recommended when TOMBO No.1995 is used in a steam or hot water line at 100°C or higher or when TOMBO No.1993 is used in a steam or hot water line at 120°C. Use a vortex™ gasket or a kamprofile gasket in a location where maintenance is difficult to carry out.

*2 : It is recommended that a thin gasket be used in order to suppress leakage due to penetration.

*3 : In the case of an FF shape, if it is not possible to obtain an adequate seating stress, it is recommended that a ring shape in which the gasket is on the inside of the bolts be used.

⟨Gasket shape⟩

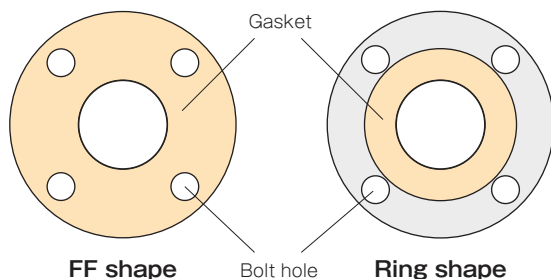

■ Precautions for use

● Using a joint sheet with a gas-type fluid

A joint sheet consists of fibers, filler and rubber which are kneaded together and then rolled. For this reason, it contains many voids. When using such a sheet with a gas-type fluid, penetration leakage is liable to occur, so pay attention to the following points.

- Apply gasket paste thinly and evenly to the seating surfaces and inner periphery.
- Apply sufficient seating stress.
- Before carrying out an airtightness test, install the gasket with paste applied and leave it for 2 to 3 hours to allow it to bond with the flange.
- **Do not use a joint sheet as a seal for a toxic gas line or a high vacuum line where even a minute amount of leakage is not allowed.**

● Using a joint sheet in a steam or hot water line

When using TOMBO No.1995 in a steam or hot water line at 100°C or higher, or when using TOMBO No.1993 in a steam or hot water line at 120°C, apply a seating stress of 29.4 N/mm² or higher and take care not to apply piping stress to the gasket.

● Using a joint sheet between stainless steel flanges

Compared to an asbestos joint sheet, a non-asbestos joint sheet contains only a small amount of soluble halogen, so it can also be used with stainless steel flanges as well. There is no need to use anti-corrosion paste.

● Additional tightening

- **When TOMBO No.1995 or TOMBO No.1993 is heated, the gasket will harden as time passes, preventing additional tightening from being performed.**
- TOMBO No.1120 can be additionally tightened, but the additional tightening at high temperature (hot bolting) cannot be performed as the allowable seating stress falls at high temperature.

● To prevent compressive breakage

To prevent compressive breakage of the joint sheet, strictly observe the following items.

Do not overtighten.

- **Do not tighten the gasket past the allowable seating stress.**
- Tighten the gasket evenly.
(If an uneven load is applied to the gasket as a result of uneven tightening, compressive breakage may occur even if the seating stress is within the allowable value. Particular care must be exercised so as not to tighten the gasket unevenly.)
- In the case of a small I.D. flange, a large tightening force is sometimes applied to the gasket, so be careful not to overtighten.

Precautions for using gasket paste

- Recommended gasket paste
TOMBO No.9105, 9106, or 9400
*Please consult us when using any paste other than the above.
- Gasket paste that must not be used
Do not use the following kinds of paste as they may cause compressive breakage below the allowable seating stress.
Solvent-type liquid packing (It may swell the gasket.)
Silicone-type oil or grease (It may increase the slipping of the gasket.)

Tightening gasket at high temperature (hot bolting)

Hot bolting may cause compressive breakage even below the allowable seating stress.

● The surface sometimes becomes white, but this has no effect on performance.

Applicable standards

- JIS R 3453 "Compressed fiber jointing"
- ASME B 16.21
"Nonmetallic Flat Gaskets for Pipe Flanges"
- JIS F 0602
"Shipbuilding - Non-asbestos gasket to cargo piping system - Application standard"
(HJ TOMBO No. 1995, TOMBO No. 1993, TOMBO No. 1991-NF, TOMBO No. 1938)
- JIS F 7102
"Standard for Using Gaskets and Packing for Pipes in Marine Engines"
(HJH TOMBO No. 1995, HJT TOMBO No. 1993)



Comparison of fluororesin gaskets

Product name

Features

Construction

Service range

Recommended service range
Usable range (The usable range depends upon the conditions. Be sure to consult us in advance.)

TOMBO No.

1133

CLINSIL™ Clean



Conforms to the Standards and criteria for food and food additives, etc. (S.D.2: Public Notice No. 370 of the Ministry of Health & Welfare, 1959) stipulated by the Food Sanitation Act



- Can be used with a wide range of fluids including acids, alkalis, petroleum, petrochemical products, organic solvents, hot oil, heating medium gas, and steam. (Excluding some strong alkalis and strong acids.)
- Has the highest heat resistance of all fluororesin gaskets.
- Can also be used where electrical insulating performance is necessary.

Main constituents: PTFE, alumina

Water-type fluid

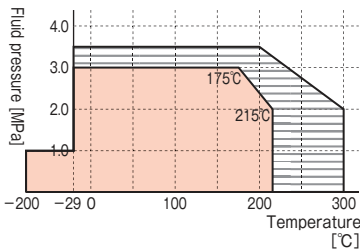

Oil-type or corrosive fluids

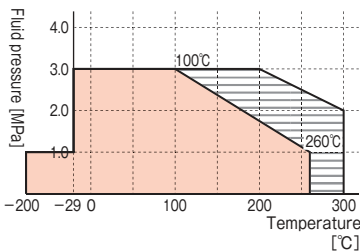

Gas-type fluid

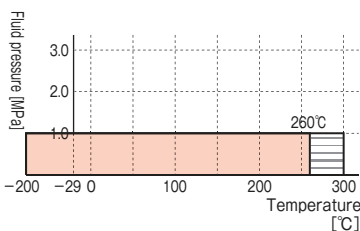

* The greater the thickness, the larger is the deformation due to creep. For this reason, it is recommended that you select a gasket of 1.5 mm in thickness for a gas line which exceeds 200°C.

TOMBO No.

9007-SC

NAFLON™ special carbon filler filled PTFE cut gasket



- Can be used with strong alkaline fluids that do not permit TOMBO No.1133 to be used. (It cannot be used with nitric acid, concentrated sulfuric acid, chromic acid, or other oxidizing fluids.)

Main constituents: PTFE, carbon

Water-type, oil-type or corrosive fluids

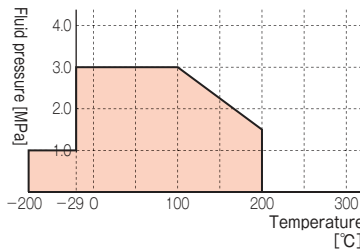

Gas-type fluid

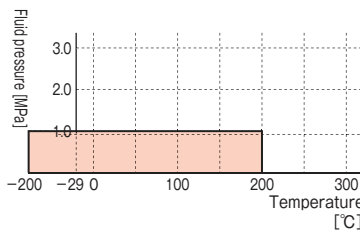

Information

Creep is deformation that occurs after the lapse of a certain time after a material has been exposed to a certain temperature and stress. Creep at normal temperature is also called "cold flow".

TOMBO No.

9007-LC

NAFLON™ special filler filled PTFE cut gasket



- Can be used with strong acidic fluids that do not permit TOMBO No.1133 to be used. (It cannot be used with hydrofluoric acid or strong alkalis.)
- Can be used where electrical insulating performance is necessary.

Main constituents: PTFE, silica

Water-type, oil-type or corrosive fluids

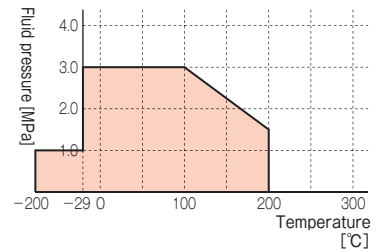

Gas-type fluid

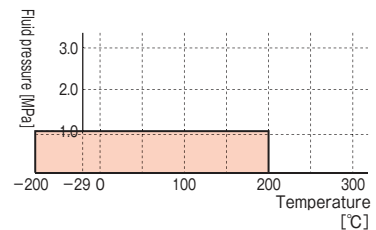

These gaskets are based on fluororesin that has excellent heat resistance and chemical resistance. A gasket that is blended with a filler, such as alumina, has reduced deformation because of the filler, so compared to a gasket that consists of PTFE alone, these gaskets do not creep even at high temperature.

TOMBO No.

9007-GL

NAFLON™ GL gasket



- This gasket is very flexible, so it is suitable for glass-lined pipes, plastic pipes, etc. where a large tightening torque cannot be applied.

Main constituents: PTFE, silica filler

Water-type, oil-type or corrosive fluids

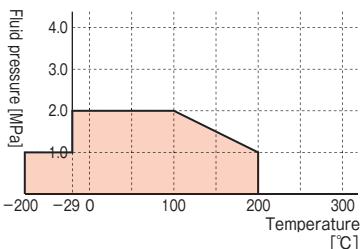

Gas-type fluid

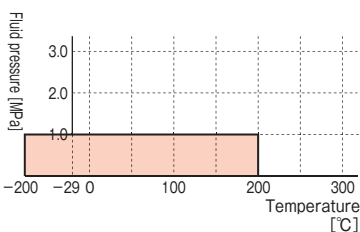

- When using TOMBO No.9007-GL or 9007-SGM in a gas-type fluid
- A ring-shaped (FR type) gasket is recommended (because the use of an FF type may fail to generate sufficient seating stress).
 - In order to improve the sealing performance, it is recommended that TOMBO No.9400 (NAFLON™ paste) be used as well.

TOMBO No.

9007-FD

NAFLON™ FD gasket



- This gasket is more flexible than TOMBO No.9007-GL.
- Because this gasket is porous, it is not suitable for a gas-type fluid.

Main constituents: PTFE, silica filler

Water-type, oil-type or corrosive fluids

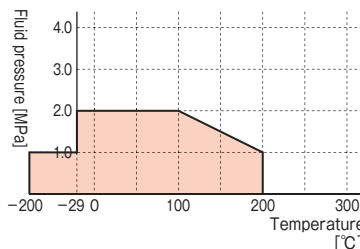

Gas-type fluid

TOMBO No.9007-FD is of a porous construction, so it is not recommended for use with a gas-type fluid.

TOMBO No.

9096-SGM

SGM™ gasket

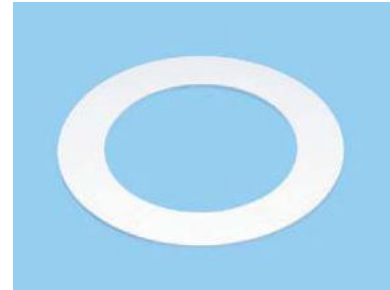

- This gasket is very flexible.
- Because it does not contain filler, it can be used in a line where contamination is not permitted.
- Can be used where electrical insulating performance is necessary.

Main constituents: Rolled PTFE

Water-type, oil-type or corrosive fluids

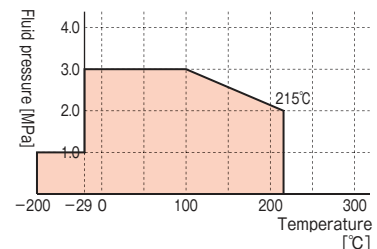

Gas-type fluid

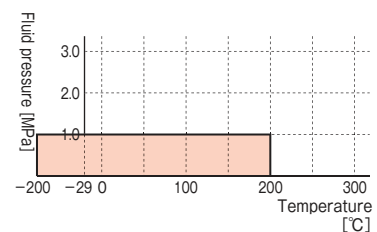

Product name
Features
Construction
Service range
Recommended service range
Line up

TOMBO No.

9007

NAFLON™ PTFE cut gasket

 Conforms to the Standards and criteria for food and food additives, etc. (3-D-2, Public Notice No. 370 of the Ministry of Health & Welfare, 1959) stipulated by the Food Sanitation Act

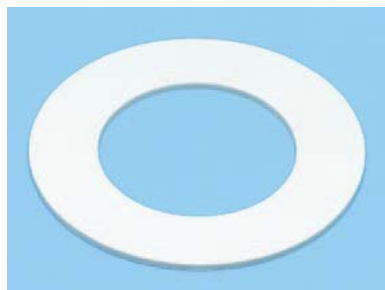

- This is a pure PTFE sheet, so it is suitable for use with fluids that are not permitted to become contaminated.
- This gasket is resistant to virtually all conceivable chemicals, but cannot be used at a temperature of 100°C or higher because deformation due to creep becomes large.

Main constituents: PTFE

* Compared to a gasket that contains a filler, this gasket is liable to creep. Use it with a grooved flange (T&G) as a general rule.

Water-type, oil-type or corrosive fluids

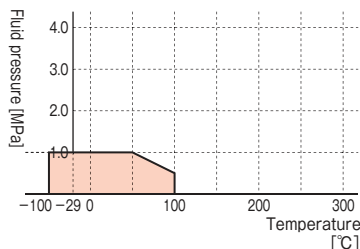

Gas-type fluid

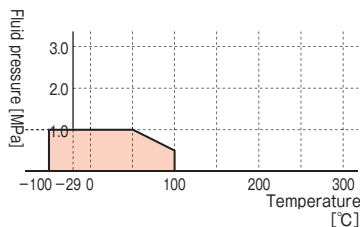

TOMBO No.9007-ST

Denatured PTFE gasket. Compared to TOMBO No.9007, this gasket has high creep resistance, so it can be used up to 150°C.

TOMBO No.

9007-LP

NAFLON™ LP gasket



- This gasket is less permeable than PTFE when used with a chemical liquid or gas. It is thus suitable for use with highly permeable halogen-based fluid, for example.

Main constituents: PFA

Water-type, oil-type or corrosive fluids

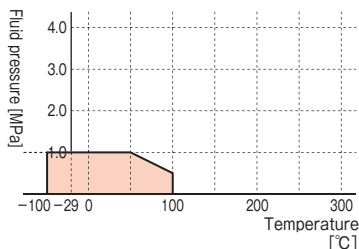

Gas-type fluid

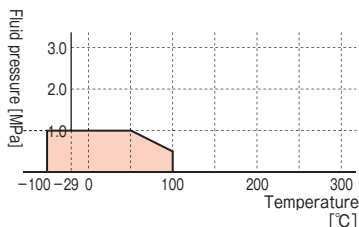

TOMBO No.

9007-G20

NAFLON™ glass fiber-filled PTFE cut gasket



- Standard PTFE gasket containing a filler.
- Cannot be used with hydrofluoric acid or strong alkali.

Main constituents: PTFE, glass fiber

Water-type, oil-type or corrosive fluids

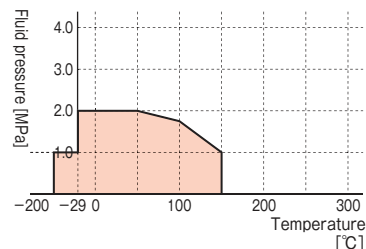

Gas-type fluid

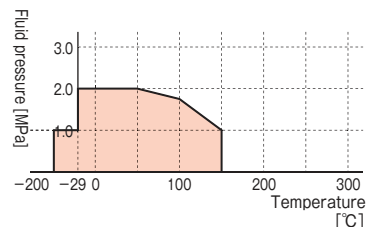



Design criteria

TOMBO No.		1133	9007-SC	9007-LC	9007-GL	9007-FD	9096-SGM	9007	9007-LP	9007-G20
Gasket coefficient m [—]	1.0 t	3.50	—	3.50	—	—	2.50	3.50	—	3.50
	1.5 t	2.75	3.20	3.20	—	—	2.50	3.20	—	3.20
	2.0 t	2.75	3.00	3.00	—	—	2.50	3.00	3.00	3.00
	3.0 t	2.00	2.50	2.50	2.50	2.50	2.50	2.50	—	2.50
Minimum design seating stress σ_y [N/mm ²]	1.0 t	44.8	—	24.5	—	—	19.6	24.5	—	24.5
	1.5 t	25.5	22.5	22.5	—	—	19.6	22.5	—	22.5
	2.0 t	25.5	19.6	19.6	—	—	19.6	19.6	19.6	19.6
	3.0 t	11.0	19.6	19.6	19.6	19.6	19.6	19.6	—	19.6
Minimum seating stress σ^3 [N/mm ²]	Water-type or oil-type fluid	14.7	14.7	14.7	14.7	14.7	19.6	10.8	14.7	12.7
	Gas-type fluid	34.3	29.4	24.5	14.7	—	39.2	19.6 ^{*1} 14.7 ^{*2}	14.7	24.5 ^{*1} 19.6 ^{*2}
Allowable seating stress [N/mm ²]		150.0	58.8	49.0	39.2	39.2	117.6 ^{*3}	39.2	29.4	49.0

*1 : Minimum seating stress for a thickness of 1.0t or 1.5t.

*2 : Minimum seating stress for a thickness of 2.0t or 3.0t.

*3 : The allowable seating stress for a thickness of 2.0t or 3.0t is 78.4N/mm².

Standard dimensions

TOMBO No.		1133	9007-SC	9007-LC	9007-GL	9007-FD	9096-SGM	9007	9007-LP	9007-G20
Maximum O.D. [mm]	1.0 t	φ 610	—	φ 1200	—	—	φ 1380	φ 1200	φ 277	φ 1200
	1.5 t	φ 1250	φ 1200							
	2.0 t	φ 1430	φ 1200	φ 1430	φ 600	φ 1220				
	3.0 t									
Standard thickness	1.0 t	●	—	●	—	—	●	●	—	●
	1.5 t	●	●	●	—	—	●	●	—	●
	2.0 t	●	●	●	—	—	●	●	●	●
	3.0 t	●	●	●	●	●	●	●	—	●

* Gaskets indicated by the yellow areas in the drawing can be made larger than that indicated by employing welding.

Basic physical properties

TOMBO No.		1133	9007-SC	9007-LC	9007-GL	9007-FD	9007	9007-LP
Thickness [mm]		1.5	1.5	1.5	3.0	3.0	1.5	2.0
Specific gravity [g/cm ³]		2.74	2.06	2.30	1.94	1.62	2.18	2.18
Tensile strength [N/mm ²]		18	24	18	22	17	34	28
Compression ratio [%]	34.3MPa	5	4	5	7	10	20	9
Recovery [%]		47	67	55	73	57	48	78
Stress relaxation ratio [%]	100°C × 22h	27	56	50	62	71	73	65
	200°C × 22h	59	79	74	87	90	—	—

* The above values are measured values. They are not standard values.

Precautions for fluororesin products

Precautions concerning design and selection

● Finish of the gasket seat

The recommended gasket seat when using a fluororesin gasket is as follows.

- For sealing liquid: 6.3 μm Ra
- For sealing gas: 3.2 μm Ra

Precautions for use

● Fluids for which a fluororesin gasket is not suitable.

- Do not use a PTFE gasket with molten alkali metal, high-temperature fluorine, chlorine trifluoride or other fluid that corrodes PTFE.
- When a fluororesin gasket is used with a monomer-based fluid, the fluid may permeate into the gasket, resulting in polymerization. In such a case, it is recommended that you either replace the gasket at shorter intervals, or use a vortex™ gasket.

● Gas-type fluid

- When using a fluororesin gasket to seal gas, use TOMBO No.9400 (NAFLON™ paste) together in order to improve the sealing performance.



TOMBO No. 9010-NA series

NAFLON™ PTFE cushion gasket

Precautions for use
P.23

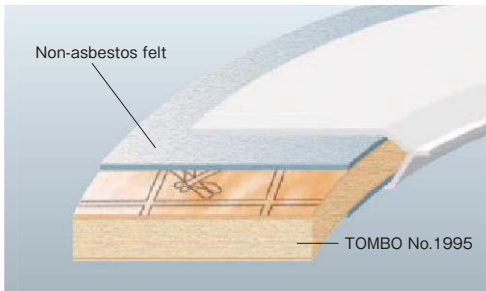

This is a PTFE-clad type gasket consisting of a core made of a joint sheet, for example, covered with an outer PTFE skin. The sealing face is completely covered by a film of PTFE, providing resistance to contamination and also resistance to chemicals. This gasket is used in a wide variety of applications including fine chemicals, petrochemicals, pharmaceuticals, foodstuffs, and general industries.

Fluororesin gaskets

■ How to read a TOMBO No. When placing an order, specify the following product specifications (TOMBO No.).

TOMBO No. **9010** — **NA** — **A** — **5**

Shape		Kind of core material
Shape	Indication symbol	Indication symbol
	Standard type A	 TOMBO No.1995 5
	Large bore type*1 B	 TOMBO No.1995 Felt 6
	Right-angled type AS	 TOMBO No.1120 7
	Fully-covered type R-A R-AS	 TOMBO No.1120 Felt 8
	For NAFLON-lined pipes*2 FG	 TOMBO No.1120 SUS mesh 9

*1 : Gaskets with an O.D. of 1000 mm or larger can be manufactured. However, because there is a heat seal at one location, the sealing performance is somewhat inferior to the A type (standard type). It is thus recommended that TOMBO No.9400 (NAFLON paste) be used as well.

*2 : If you use a gasket of standard dimensions in a NAFLON-lined pipe, the dimensions will not match each other, which may result in leakage. For this reason, use the FG series gasket the dimension of which is appropriate for NAFLON-lined pipes. The construction of the FG series is the same as that of the A type or AS type.

Other lineups

- TOMBO No.9010-NA-K (This product is sewn around the outer periphery.)
- TOMBO No.9010-NA-KH (This product is sewn around the outer periphery and also has a hand grip.)

Examples of TOMBO No.

9010-NA-A-5

Type: Standard type Core: TOMBO No.1995

9010-NA-AS-7

Shape: Right-angled type Core: TOMBO No.1120

9010-NA-R-A-5

Shape: Fully-covered type Core: TOMBO No.1995

Service range

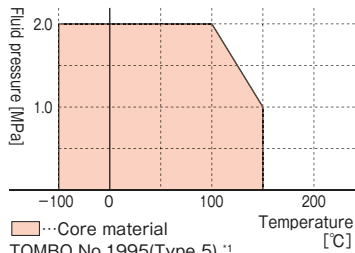

Core material
TOMBO No.1995(Type 5) *1
TOMBO No.1995+Felt(Type 6) *1
TOMBO No.1120(Type 7)
TOMBO No.1120+Felt (Type 8)

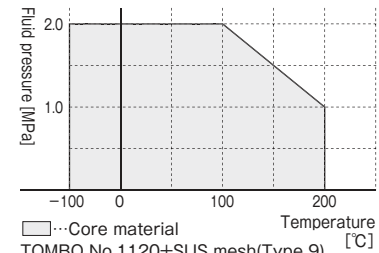

Core material
TOMBO No.1120+SUS mesh(Type 9) [°C]

*1 : It is not recommended that these gaskets be used in places where the temperature fluctuates 100°C or more, where the pressure frequently fluctuates, or where maintenance is difficult to carry out.

Design criteria

Shape	Type A	Type B	Type AS	
Kinds of core materials [TOMBO No.]	1995 (Type 5) 1995+Felt (Type 6) 1120 (Type 7) 1120+Felt (Type 8)	1120+SUSMesh (Type 9)	1995 (Type 5) 1995+Felt (Type 6) 1120 (Type 7) 1120+Felt (Type 8) 1120+SUS mesh (Type 9)	
Gasket coefficient m [-]	3.50	3.50	4.00	
Minimum design seating stress γ [N/mm ²]	14.7	19.6	19.6	
Minimum seating stress σ_3 [N/mm ²]	Water-type or oil-type fluids	9.8	14.7	14.7
	Gas-type fluid	14.7	19.6	19.6
Allowable seating stress [N/mm ²]	29.4	39.2	29.4	

Standard dimensions

Shape	Type A	Type B	Type AS
Minimum I.D. [mm]	φ 16	φ 300	φ 20
Maximum O.D. [mm]	φ 1000	Arbitrary	φ 700

⚠️ Precautions for NAFLON™ PTFE cushion gaskets

PTFE-clad type gaskets can be used for a wide range of applications, but there is a possibility of trouble occurring in the following cases. It is recommended that you use a fluororesin gasket such as the TOMBO™ No.1133 or TOMBO No.9007 series, as far as possible.

Case	Assumed phenomenon	Remedy
Tightened with an excessive force.	A joint sheet may deform or break (compression breakage), resulting in leakage. This phenomenon is particularly liable to occur in small bore products or fluororesin-lined pipes.	●Tighten the cushion gasket using a tightening torque that is lower than the allowable seating stress.
Used with a permeable fluid Nitric acid, ethylene oxide, halogens (chlorine, bromine, etc.), molten sulfur, monochloroacetic acid.	During long-term use, the fluid may permeate into the gasket through the PTFE covering material, damaging the core material and causing the gasket to lose its function.	●Replace the gasket at shorter intervals. ●Use a PTFE cut gasket.
A gasket of a type that was covered only on the inside diameter side (Type A, B and AS) was used on a pipe in a vacuum condition.	The PTFE outer skin may be drawn into the pipe.	●Use a fully-covered type (Type R-A and R-AS) or a sewn-around-outer-periphery type (Type -K).
Standard type (Type A) is used.	Fluid may accumulate around the gasket due to its construction.	●Use a right-angled type (Type AS). ●Use a gasket of the proper I.D.
Gasket with core material of joint sheet + felt (Core type No.: 6 or 8) is used.	If the core material is wet by a fluid, the compression breakage strength will fall. If soapy water or rainwater penetrates the gasket, causing the felt to soften and be pushed outward, the seating stress of the gasket may fall, resulting in possible leakage.	●Store the gasket in a waterproof pouch or the like. ●After installing the gasket, take care that there is no ingress of rainwater. ●Ensure that the tightening force is not insufficient.
The gasket was installed at a location where there was insufficient space between the flange faces.	Defective sealing occurs due to breaking of the gasket or curling of the PTFE outer skin.	●Use a fully-covered type (Type R-A and R-AS) or a sewn-around-outer-periphery type (Type -K).
Air bubbles were found between the PTFE outer skin and the core material when an airtightness test was performed.	Air included in the core material and also air stagnating on the inner periphery side has been discharged.	●Wait for a certain time after applying the internal pressure load before carrying out an airtightness test. * This phenomenon is particularly liable to occur in the case of a gasket that has felt core material (Core type No.: 6 or 8).



TOMBO No. 9096 series

Nichias Soft Seal™



Conforms to the Standards and criteria for food and food additives, etc.

(3-D-2, Public Notice No. 370 of the Ministry of Health & Welfare, 1959) stipulated by the Food Sanitation Act
* Gaskets both with and without adhesive tape conform to the above.

Precautions for use
P.23

This is a PTFE soft type gasket. It is extremely soft, and the version with adhesive tape can be easily installed on sealing faces that are of complicated shapes. It is suitable as a piping sealant, or as a gasket for tanks, casings, ducts, pressure vessels, reaction tanks, lined containers, large bore equipment, and other applications.

■ How to read TOMBO No. When placing an order, specify the following product specifications (TOMBO No.).

TOMBO No. **9096** — **R** — **10**

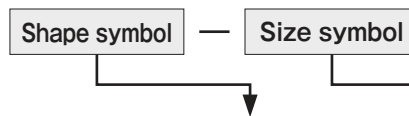

Shape	Shape symbol	Size			Size symbol
		Width [mm]	Thickness [mm]	Standard length/roll [m]	
Elliptical	No shape symbol	3.0	1.5	30	3
		6.0	3.0	15	6
		9.0	4.5	8	9
Not available without adhesive tape		12.0	6.0	5	12



Shape	Shape symbol	Size		Size symbol
		Width [mm]	Standard length/roll [m]	
Round	R	10.0	5	10
		12.0	5	12
		20.0	5	20
Not available without adhesive tape				



Shape	Shape symbol	Size			Size symbol
		Width [mm]	Thickness [mm]	Standard length/roll [m]	
Tube	TB	2.0	1.0	30	21
		3.0	2.0	30	32
		4.0	3.0	30	43
		5.0	4.0	20	54
		6.0	5.0	20	65
		7.0	6.0	20	76
		8.0	7.0	10	87
		10.0	8.0	10	108
Not available without adhesive tape		12.0	10.0	10	1210

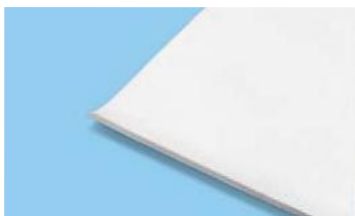

Shape	Shape symbol	Size		Size symbol
		Width [mm]	Thickness [mm]	
Sheet	ST (with adhesive tape)	1500 × 1500	1.0	1.0
			1.5	1.5
			2.0	2.0
			3.0	3.0
			4.0	4.0
			0.5	0.5
	S (without adhesive tape)	1500 × 1500 1500 × 3000	1.0	1.0
			1.5	1.5
			2.0	2.0
			3.0	3.0
			4.0	4.0
			5.0	5.0^{*1}
			6.5	6.5^{*1}
			10.0	10.0

*1 : Not available in 1500 × 3000 size.

Examples of TOMBO No.

9096-03	Shape: Elliptical	Size: Width 3mm, Thickness 1.5mm
9096-ST-1.0	Shape: Sheet (with adhesive tape)	Size: Width 1500×1500mm, Thickness 1.0mm
9096-TB-21	Shape: Tubular	Size: O.D. 2.0mm, I.D. 1.0mm
9096-B-1020	Shape: Flat (without adhesive tape)	Size: Width 20mm, Thickness 1.0mm
9096-G	Shape: Cut gasket (without adhesive tape)	Size: Please specify.



Shape	Shape symbol	Size			Size symbol
		Width [mm]	Thickness [mm]	Standard length/roll [m]	
Flat	BT (with adhesive tape)	20.0	1.0	15	1020
		30.0	1.0	15	1030
		50.0	1.0	15	1050
	B (without adhesive tape)	100.0	1.0	15	1100
		20.0	2.0	5	2020
		30.0	2.0	5	2030
		50.0	2.0	5	2050
		20.0	3.0	5	3020
		30.0	3.0	5	3030
		50.0	3.0	5	3050
100.0	3.0	5	3100		



Shape	Shape symbol	Size			Size symbol
		Width [mm]	Thickness [mm]	Standard length/roll [m]	
Square	KT (with adhesive tape)	14.0	5.0	10	5014
	K (without adhesive tape)	20.0	7.0	5	7020



Shape	Shape symbol	Remarks
Cut gasket	GT (with adhesive tape)	Gaskets for JIS and JPI piping are cut from soft seal sheets.
	G (without adhesive tape)	For other dimensions, please consult us.

Scope of use

Shape		Elliptical	Sheet
Temperature [°C]		-100~260	
Pressure [MPa]	Liquid	5	2
	Gas	2	

Design criteria

Shape		Elliptical				Sheet
		3mm	6mm	9mm	12mm	
Minimum seating stress	[N/mm]	75	100	125	150	15~20



Comparison of **GRASEAL™** Gaskets

Expanded graphite sheet

Product name

TOMBO No.

1880-GR

CMGC gasket

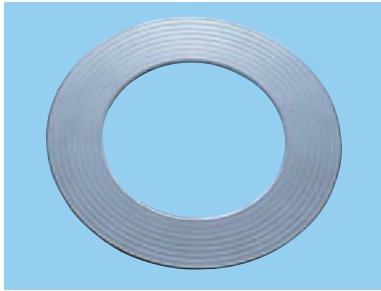

Construction

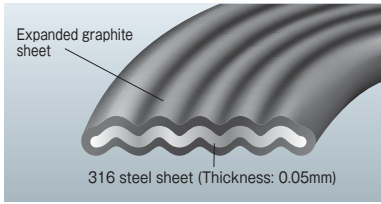

Features

- Gasket that is corrugated to concentrate the contact pressure, thus improving the sealing performance.
- Can also be formed into special shapes such as picture frame and flat face.
- Used with specially shaped flanges, valve bonnets, heat exchangers, and so on.

Service range

Service temperature

Oxide atmosphere -240~400°C

Non-oxide atmosphere -240~800°C

Service pressure

~5.2MPa

Remarks

TOMBO No.

1215-A

GRASEAL™ gasket PM-A

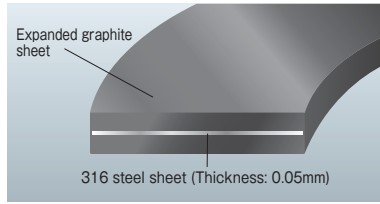

- Has excellent handling ability, and can be formed into complicated shapes.
- Used with specially shaped flanges, valve bonnets, heat exchangers, and so on.

Service temperature

Oxide atmosphere -240~400°C

Non-oxide atmosphere -240~800°C

Service pressure

~5.2MPa

[Other lineups]

A type with SUS304 steel sheet core is available. Its heat resistance and pressure resistance are not significantly different from those of TOMBO No.1215-A, so select a gasket that matches your specifications.

- TOMBO No.1215 ... SUS304 with a thickness of 0.1mm
- TOMBO No.1215-B-E04 ... SUS304 with a thickness of 0.4mm
- TOMBO No.1215-B-E10 ... SUS304 with a thickness of 1.0mm

[Impermeability treatment]

The TOMBO No.1215 series contains a lineup that has been treated to make it impermeable.

- TOMBO No.1215-T
- TOMBO No.1215-AT
- TOMBO No.1215-BT-E04
- TOMBO No.1215-BT-E10

TOMBO No.

1210-A

GRASEAL™ gasket MI-A

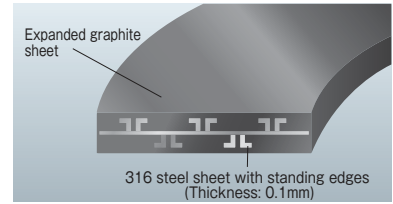
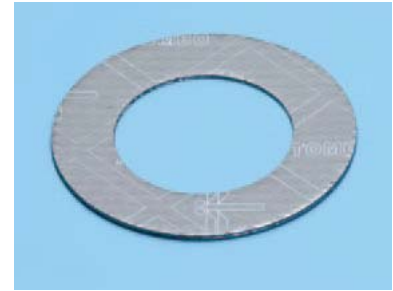

- Has higher strength than TOMBO No. 1215-A.

*This type is recommended in the case where the strength of TOMBO No.1215-A is insufficient, or when there is a limitation imposed by the specifications.

Service temperature

Oxide atmosphere -240~400°C

Non-oxide atmosphere -240~800°C

Service pressure

~5.2MPa

Information

Oxide atmosphere: This refers to the state in which a gas contains a large quantity of oxygen, ozone, nitrogen dioxide or other oxidized gas. *Ambient atmosphere corresponds to an oxide atmosphere.

Non-oxide atmosphere: This refers to a state in which a space is filled with a noble gas, nitrogen, nitrogen dioxide, or the like.

Impermeability treatment: Expanded graphite is graphite that has been expanded between the crystalline layers. It has a porous construction, so a GRASEAL™ gasket is unable to completely prevent minute amounts of gas leakage. If high gas sealing performance is demanded, use a gasket that has been subjected to impermeability treatment and to which sufficient seating stress for sealing can be applied.

When impermeability treatment is carried out, the heat resistance will fall (maximum service temperature: 260°C), but the gas sealing performance will improve.

A GRASEAL™ gasket is a cut gasket made from expanded graphite sheet or an expanded graphite sheet containing a metallic reinforcing plate.

TOMBO No.

1200

GRASEAL™ gasket

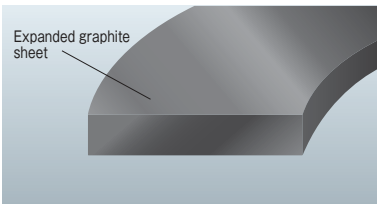

- More economical than other GRASEAL™ gaskets.
- This gasket has lower strength and poor handling compared to a gasket containing a steel plate. For this reason, it should be used only for a nominal diameter of 4 inches or less.

Service temperature

Oxide atmosphere -240~400°C

Non-oxide atmosphere -240~800°C

Service pressure

~3.0MPa

TOMBO No.

1220/1221

GRASEAL™ gasket tape (Plane/Crinkle)

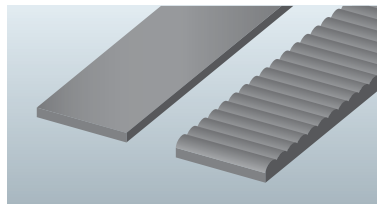

- Can be directly applied to the flange face as a free size gasket.
- Can be bonded to a hard gasket (TOMBO No.1850 or 1841) as an auxiliary sealing material.

*Do not apply this tape to a soft gasket such as a joint sheet.

Service temperature

Oxide atmosphere -240~400°C

Non-oxide atmosphere -240~800°C

Service pressure

~3.0MPa

[Examples of use]

- TOMBO No.1220, 0.13mm in thickness
As a sealant tape for a high temperature screw coupling
(Maximum service temperature: 300°C)
- TOMBO No.1220, 0.25mm in thickness
As a seal for a flange of 18 inches or larger bore
- TOMBO No.1221
As a seal for a flange of 16 inches or smaller

Product name

Construction

Features

Service range

Remarks

Details of design criteria, standard dimensions, and precautions P.30

Dimension table P.64 - 73



Design criteria

TOMBO No.		1880-GR	1215-A	1210-A	1200
Gasket coefficient m	[-]	2.00	2.00	2.00	2.00
Minimum design seating stress y	[N/mm ²]	26.0	29.4	29.4	26.0
Minimum seating stress σ_3	Water-type or oil-type fluid	14.7	14.7	14.7	14.7
	Gas-type fluid ^{*1}	39.2	49.0	49.0	49.0
Allowable seating stress	0.8 t	—	294.0	294.0	170.0
	1.6 t	166.0	167.0	167.0	106.0
	3.2 t	166.0	98.0	98.0	79.0

*1 : There may be cases that it is difficult to obtain the required seating stress by the standard dimension gaskets.

Standard dimensions

TOMBO No.	1880-GR	1215 1215-T	1215-A 1215-AT	1215-B-E04 1215-BT-E04	1215-B-E10 1215-BT-E10	1210-A	1200
Nominal thickness [mm]	1.6, 3.2	0.8, 1.6, 3.2	0.8, 1.6, 3.0	1.2, 2.0	1.8, 2.6	1.5, 2.0, 3.0	0.4, 0.8, 1.6, 3.2
Reinforcing plate thickness [mm]	0.8	0.10	0.05	0.40	1.00	0.10	—
Diameter of gasket that can be manufactured [mm]	φ 3300 ^{*1}	φ 580	φ 1480 ^{*3}	φ 985 ^{*2}	φ 985 ^{*2}	φ 1480	φ 985
Minimum width [mm]	10	10	5	10	10	—	—

*1 : For a dimension exceeding φ 3300mm, please consult us.

*2 : If the O.D. of the gasket exceeds φ 900mm, weld a stainless steel sheet of 0.4mm or 1.0mm thickness at several locations, or bond an expanded graphite sheet at several locations.

*3 : A gasket with a nominal thickness of 0.8mm can be manufactured to a maximum diameter of φ 985mm.

[GRASEAL™ tape]

TOMBO No.	1220			1221	
Thickness [mm]	0.13	0.25	0.25	0.38	0.38
Width [mm]	12.7	12.7	25.4	12.7	25.4
Length [mm]	7.6	7.6	15.2	7.2	14.2

⚠ Precautions concerning GRASEAL™ gaskets

Precautions concerning design and selection

● Finish of the gasket seat

The recommended gasket seat surface roughness when using a GRASEAL gasket is as follows.

- For sealing liquid: 6.3μm Ra max.
- For sealing gas: 3.2μm Ra max.

● Dimension of the gasket

When a GRASEAL gasket is used to seal the gas-type fluid, care should be taken that it is difficult to obtain the required seating stress (σ_3 or the like) by the gasket of the standard dimension.

Precautions for use

An expanded graphite gasket is liable to deform or become damaged, so be very careful when handling it. If the gasket surface is deformed or greatly damaged, it may be impossible to maintain its intrinsic performance.

- Do not place a heavy object on the gasket.
- Do not strike the gasket with a hard object.
- Do not step on the gasket or bend it with your foot.
- When using a cutter or other sharp implement to unpack the gasket, take care not to damage the gasket.
- Do not pull out the gasket until you have completely unpacked it.

Fluids for which a GRASEAL™ gasket is not suitable.

Classification	Name of fluid
Oxidizing acid	Nitric acid, concentrated sulfuric acid, hot sulfuric acid, chromic acid, mixed acid, etc.
Oxidizing salt	Nitrate, chloride, hypochlorite, etc.
Halogen compound	Bromine, fluorine, iodine, chlorine dioxide, etc.
Combustible gas	Oxygen (pure oxygen)

Applicable standards (TOMBO No.1200, 1210, 1215 series)

■ JPI-7S-79

"Expanded Graphite Sheet Gasket for Piping"

■ JIS F 7102

"Standard for Using Gaskets and Packing for Pipes in Marine Engines"



Semi-metal gasket

A semi-metal gasket consists of a combination of a metal, such as a stainless steel sheet, and a non-metal, such as expanded graphite. It can be used at higher temperature and pressure than a soft gasket. Nichias offers the following semi-metal gaskets.

For details of kammprofile gaskets, see P.32, P.35 and P.36.

For details of vortex™ gaskets, see P.32 to 34, and P.38 to 45.

For details of metal jacket gaskets, see P.34, P.46 and P.47.

Kammprofile gaskets

〈Standard type〉

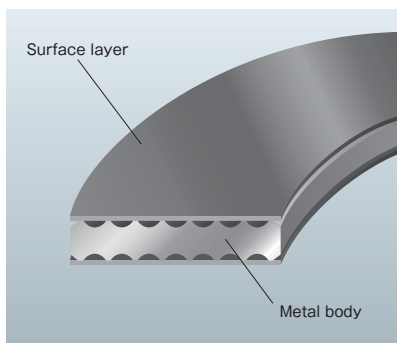

〈Outer ring type〉

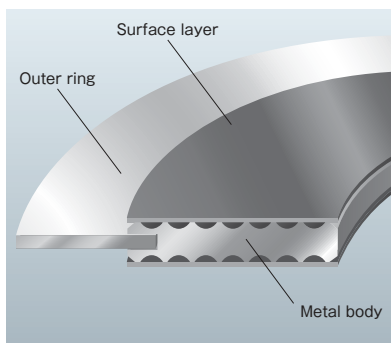

A kammprofile gasket is a semi-metallic gasket consisting of an expanded graphite sheet or a PTFE sheet bonded to both faces of a metal ring that has a special groove cut in it. It features a construction in which the convex surface has been flattened so as to greatly reduce damage to the flange.

Vortex™ gaskets

〈Basic type〉

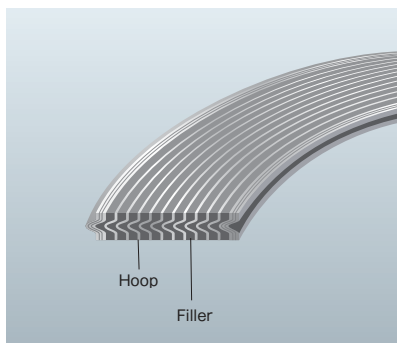

〈Inner and outer ring type〉

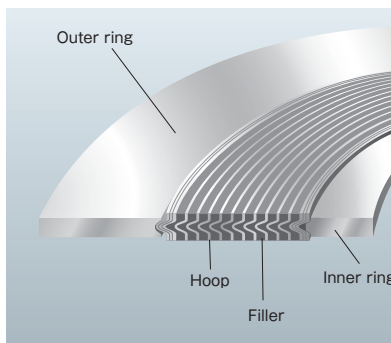

A vortex gasket consists of alternate layers of thin V-shaped metal band plates called hoops and cushion material called filler, wound in the shape of a vortex. There is also a type that has metal reinforcing material (inner and outer rings). When using this type of gasket, it is necessary to select an appropriate shape according to the type of flange to be used.

Metal jacketed gasket

〈Flat type〉

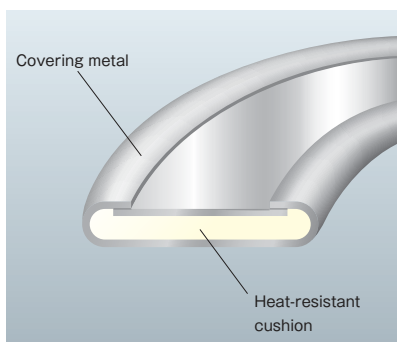

〈Corrugated type〉

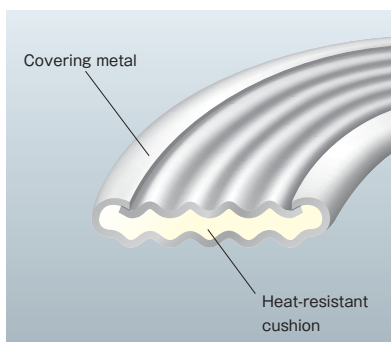

A metal jacketed gasket is a gasket that has an inorganic heat-resistant cushion covered by a thin metal plate. It is manufactured in various shapes and covering methods depending upon the intended application and the location where it is to be used. It is used for high temperature coupling flanges and man-holes, etc. for heat exchangers, pressure vessels, towers and vessels, equipment, valves, and so on.



Comparison of semi-metal gaskets

Product name

Construction

Features

Service range

Recommended service range
Usable range (The usable range varies according to the conditions of use. Be sure to consult us in advance.)

TOMBO No.

1891 series

Kammprofile gasket

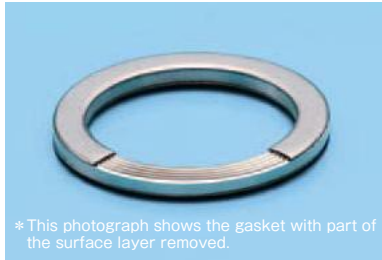

* This photograph shows the gasket with part of the surface layer removed.

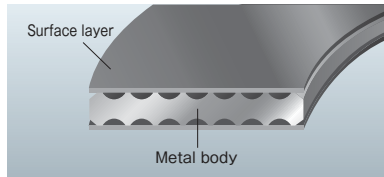

- Can be used even under severe conditions encountered in a heat cycle, and exhibits excellent sealing performance even when a small tightening force is used.
- There is no need for an inner ring to stop buckling. This enables this gasket to be designed with a narrow width.
- There is no need to worry about the gasket breaking up even in the case of a large bore gasket.
- Suitable for use in heat exchangers and pressure vessels.

Water-type, oil-type, gas-type or corrosive fluids

TOMBO No.1891-GR

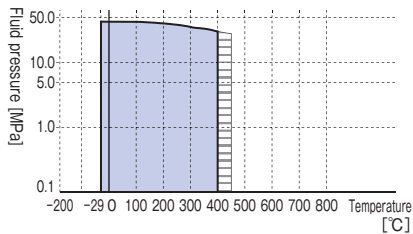

Maximum service temperature 450°C
 Maximum service pressure Class 2500 (Approx. 43MPa)

Water-type, oil-type, gas-type or corrosive fluids

TOMBO No.1891-TF

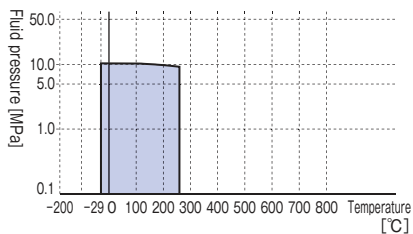

Maximum service temperature 260°C
 Maximum service pressure Class 600 (Approx. 10MPa)

* When using TOMBO No.1891 at Class 400 or higher, use an interlocking type (M&F) or a grooved type (T&G) flange.

For details of a kammprofile gasket, see P.35 and P.36.

TOMBO No.

1834R-GR series

GRASEAL™ Vortex™ gasket

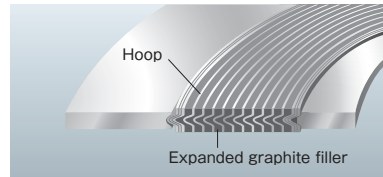

- Exhibits excellent sealing performance even under at severe conditions such as high temperature and high pressure, extremely low temperatures, or heat cycles.
- It is suitable for a variety of applications in pipes, equipment, and so on.

Water-type fluid

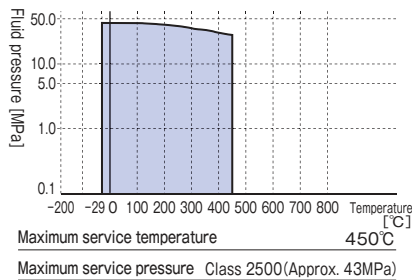

Maximum service temperature 450°C
 Maximum service pressure Class 2500 (Approx. 43MPa)

Oil-type, gas-type or corrosive fluids

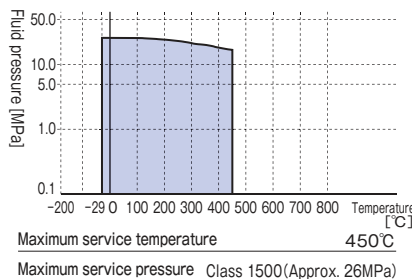

Maximum service temperature 450°C
 Maximum service pressure Class 1500 (Approx. 26MPa)

Low temperature fluids

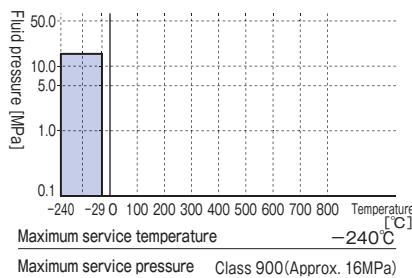

Maximum service temperature -240°C
 Maximum service pressure Class 900 (Approx. 16MPa)

TOMBO No.

9090-IOR series

NAFLON™ Vortex™ gasket

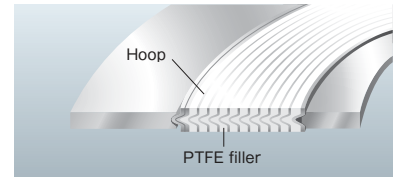

- Can be used with corrosive fluids and pure oxygen gas, in vacuum lines that require airtightness.
- Can be used in pipes, pressure vessels, heat exchangers, valve bonnets, and so on.

Water-type, oil-type, gas-type or corrosive fluids

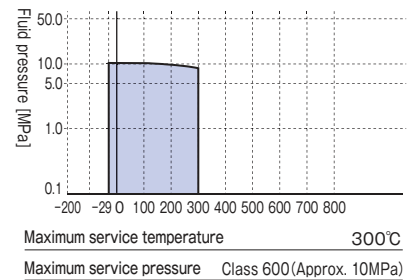

Maximum service temperature 300°C
 Maximum service pressure Class 600 (Approx. 10MPa)

Low temperature fluids

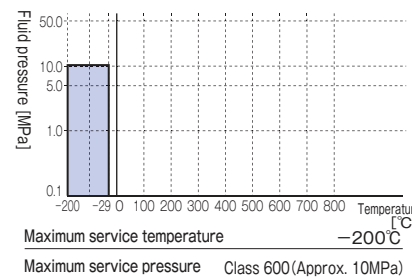

Maximum service temperature -200°C
 Maximum service pressure Class 600 (Approx. 10MPa)

These gaskets use metal as the base material, so they can be used at higher temperature and pressure compared to a sheet gasket. These gaskets fit well with the flanges, so a good seal can be obtained using a smaller tightening force than that of a metal gasket.

TOMBO No.

1834R-NA series

NA Vortex™ gasket

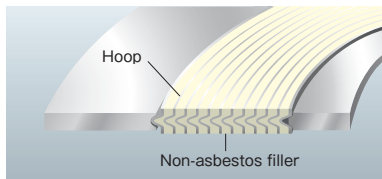

● This is an economical vortex™ gasket which uses non-asbestos (NA) paper as a filler.

* So long as there are no restrictions such as the inability to use black filler, the use of GRASEAL™ Vortex™ which has superior heat resistance and sealing performance is recommended.

Water-type fluid

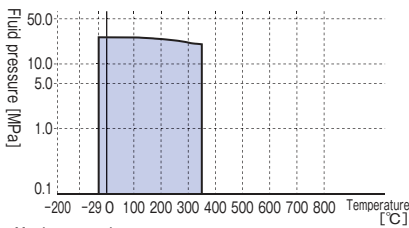

Maximum service temperature 350°C

Maximum service pressure Class 1500 (Approx. 26MPa)

Oil-type fluid

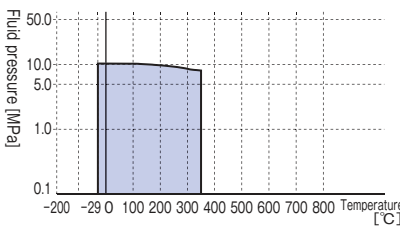

Maximum service temperature 350°C

Maximum service pressure Class 600 (Approx. 10MPa)

Gas-type fluid

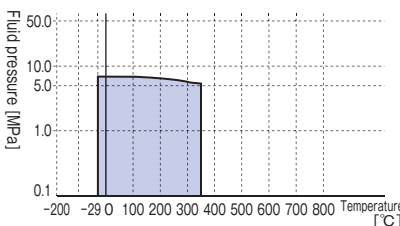

Maximum service temperature 350°C

Maximum service pressure Class 400 (Approx. 7MPa)

TOMBO No.

1836R-GS/-GM/-GH series

Vortex™ gasket -GS / -GM / -GH

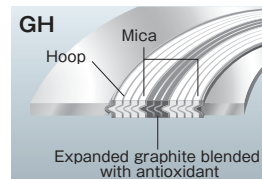
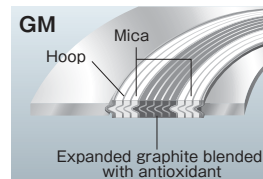
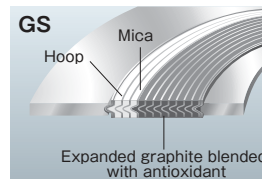
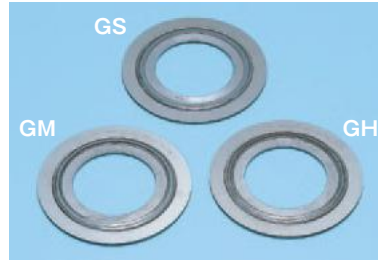

● This gasket uses a special expanded graphite filled with antioxidant, enabling it to be used at a temperature of 450°C or higher.

* The sealing performance of the normal GRASEAL™ vortex™ gasket is superior to this type.

● One of three types, -GS, -GM and -GH, can be selected according to the conditions of use.

-GS series: A location where oxygen is not contained in the internal fluid

-GM series: Temperature of 450°C or higher

-GH series: Temperature of 650°C or higher

Water-type and oil-type fluids

-GS series, -GM series

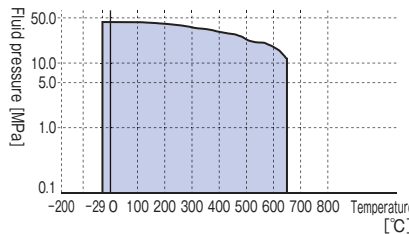

Maximum service temperature 650°C

Maximum service pressure Class 2500 (Approx. 43MPa)

Water-type and oil-type fluids

-GH series

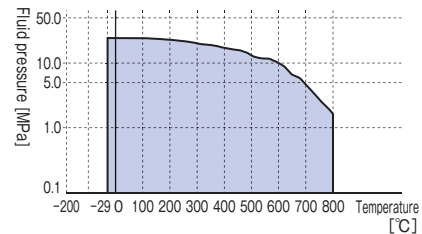

Maximum service temperature 800°C

Maximum service pressure Class 1500 (Approx. 26MPa)

Oil-type and gas-type fluids

-GS series, -GM series

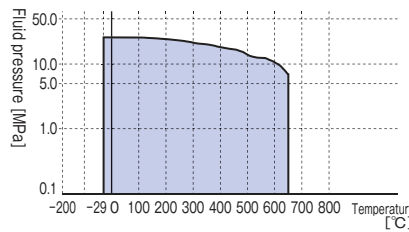

Maximum service temperature 650°C

Maximum service pressure Class 1500 (Approx. 26MPa)

Oil-type and gas-type fluids

-GH series

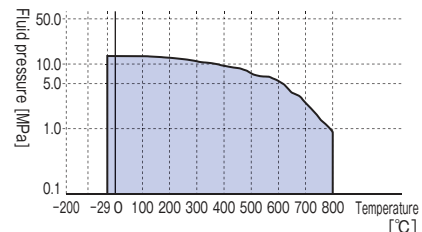

Maximum service temperature 800°C

Maximum service pressure Class 1500 (Approx. 26MPa)

* In the case of a gas-type fluid at 650°C or higher, use Class 600 or lower.

* This product has been designed to minimize the loss of expanded graphite through oxidation. If oxygen is contained in the internal fluid, however, it is conceivable that the loss of expanded graphite will start to occur when the temperature exceeds 450°C. Do not use this type of gasket at 450°C or higher if the internal fluid contains oxygen.

For details of vortex™ gaskets, see P.38 to P.45.

Product name

Construction

Features

Service range

TOMBO No.

1839R series

GRASEAL™ Vortex™ gasket -L

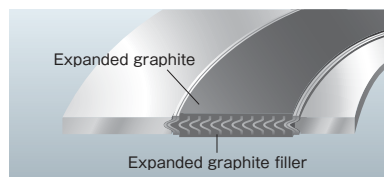

- This gasket exudes a large quantity of filler on the seal face, enabling a satisfactory seal to be obtained when using a smaller tightening force than that of a normal GRASEAL vortex gasket.
- Can be used in a low-temperature line containing LNG, LN₂, liquefied air, and so on.

Water-type, oil-type, gas-type or corrosive fluids

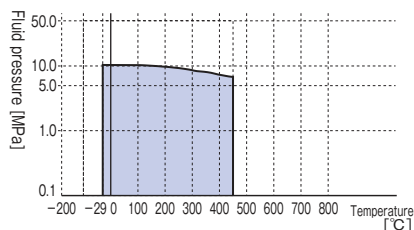

Maximum service temperature 450°C

Maximum service pressure Class 600 (Approx. 10MPa)

Low-temperature fluid

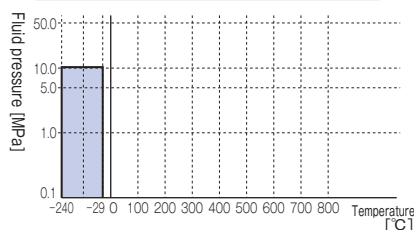

Maximum service temperature -240°C

Maximum service pressure Class 600 (Approx. 10MPa)

TOMBO No.

1839R-AL series

GRASEAL™ Vortex™ gasket -AL

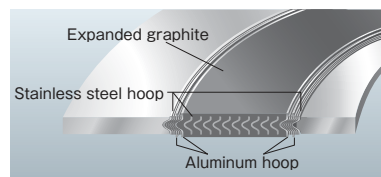

- This GRASEAL vortex gasket for aluminum flanges is constructed in such a way that it does not readily damage the flange face.
- Can be used in low-temperature lines carrying LNG, LNN₂, and so on.

Water-type, oil-type and gas-type fluids

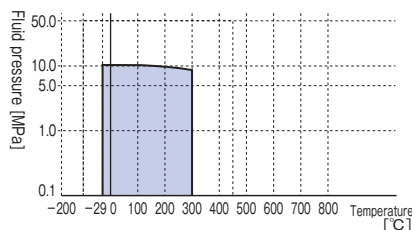

Maximum service temperature 300°C

Maximum service pressure Class 600 (Approx. 10MPa)

Low-temperature fluid

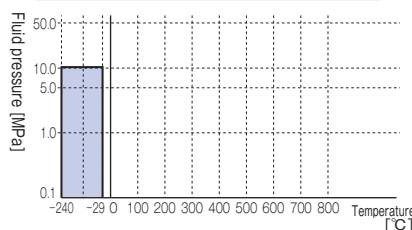

Maximum service temperature -240°C

Maximum service pressure Class 600 (Approx. 10MPa)

For details of vortex gaskets, see P.38 to P.45.

TOMBO No.

1841/1861

Metal jacketed gasket/Corrugated metal jacketed gasket



TOMBO No.1841



TOMBO No.1861

- This gasket can be manufactured in various shapes, such as a branched type, according to the particular application and the intended location.
- It is used in heat exchangers, pressure vessels, towers and vessels, equipment, valves, high-temperature coupling flanges, manholes, and so on.

The maximum service temperature of a metal jacket differs according to the type of core material and cover metal.

Maximum service temperature for different core materials

Millboard 530°C

Millboard for high-temperature 1300°C

Expanded graphite 400°C

Maximum service pressure

6MPa

Maximum service temperature by cover metal

Carbon steel 535°C

304 steel 800°C

316 steel 800°C

Copper 400°C

Aluminum 400°C

310S steel 1150°C

Monel 800°C

For details of a metal jacket gasket, see P.46 and P.47.

TOMBO No. **1891****Kammprofile gasket**

Lineup

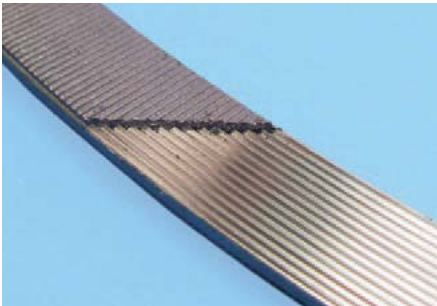

Expanded graphite clad gasket (TOMBO No.1891-GR)
* This photograph shows the gasket with part of the surface layer removed.

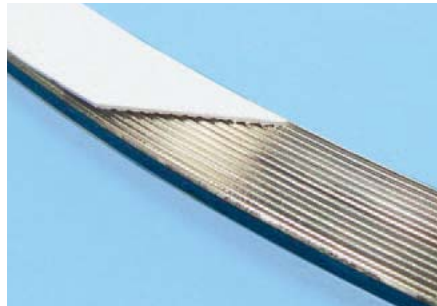

PTFE clad gasket (TOMBO No.1891-TF)

(Example of metal body material)

304 steel	Carbon steel
316L steel	329J4L
321 steel	Monel
	Titanium
	Nickel

* For other materials, please contact us.

How to read TOMBO No.

When placing an order, please specify the following product specifications (TOMBO No.).

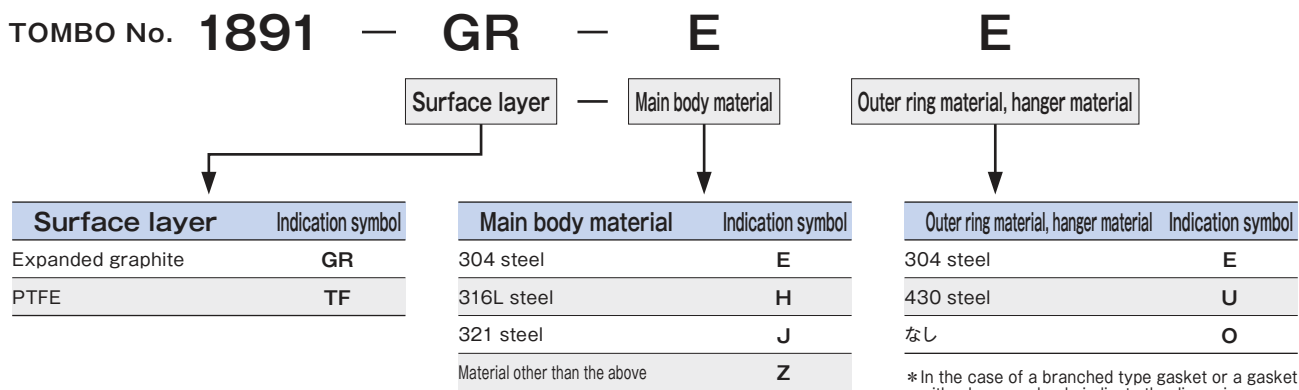

Design criteria

TOMBO No.	1891-GR	1891-TF
Gasket coefficient m	[-]	
Minimum design seating stress γ	[N/mm ²]	
Minimum seating stress σ_3	Water-type and oil-type fluids	29.4
	Gas-type fluid	39.2
Allowable seating stress	[N/mm ²]	
	450	

Standard dimensions

Standard O.D. [mm]	$\phi 4000^{*1}$
Standard thickness [mm]	4.0 (Metal thickness: 3.0, Cover material: $0.5 \times 2 = 4.0$)
Standard width [mm]	10, 13, 15, 20
Minimum manufacturable width [mm]	5 ^{*2}
Standard metal main body material	304 steel, 316L steel
Standard hanger material	304 steel
Construction	Basic type, type with hangers, branched type

*1:
For gaskets larger than $\phi 4000$ mm, please consult us. We can also manufacture gaskets to specifications other than those shown at left. Note, however, that due to structural considerations we are unable to manufacture the fully-seating type gaskets with bolt holes or irregularly shaped (track type or, elliptical type) gaskets. In such a case, please consider the use of TOMBO No.1880-GR (CMGC™ gasket).

*2:
This is the minimum width to which a gasket can be manufactured. Please note that the minimum width that can provide satisfactory sealing performance varies according to the conditions of use.

■ Design guideline concerning the standard clearance and appropriate groove depth

● Groove to gasket clearance

Gasket [mm]	Standard clearance [mm]	
	(a)	(b)
250 or lower	0.5	0.5 or higher
251 ~ 630	0.7	0.7 or higher
631 ~ 2000	1.0	1.0 or higher
2001 ~ 3000	1.3	1.3 or higher
3001 or higher	1.5	1.5 or higher

● Groove depth (when the gasket thickness is 4mm)

Flange seat type	Appropriate groove depth (f) [mm]
Tongue and groove type (T&G)	5.0 min.
Male and female type (M&F)	5.0 min.

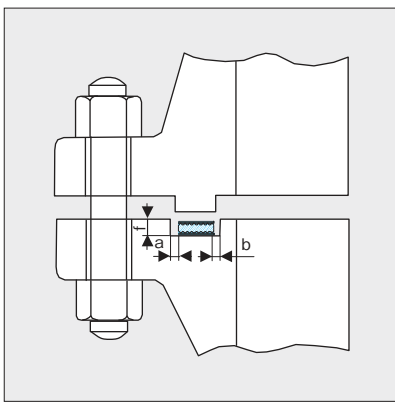

When used in a tongue and groove (T&G) type flange

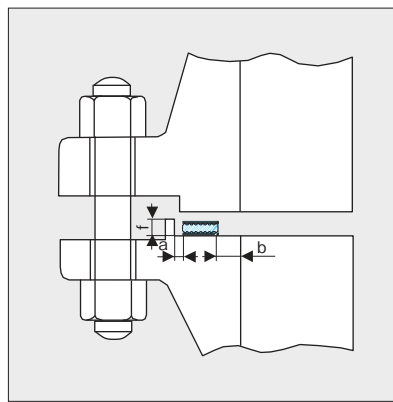

When used in a male and female (M&F) type flange

■ Flange seat type and appropriate gasket shape

Flange seat type	Full Face (FF)	Raised Face (RF)	Male and Female (M&F)	Tongue and Groove (T&G) ²
Appropriate shape	Gasket with hanger ^{*1}	Gasket with hanger ^{*1}	Basic type	Basic type

* 1 : In the case of a piping standard gasket (Class 150 /Class 300), the gasket has an outer ring.

* 2 : In the case of Class 400 or higher, the use of the tongue and groove type (T&G) flange is recommended.

⚠ Precautions for use

- A Kammprofile gasket is clad with expanded graphite or PTFE. For this reason, the surface of the gasket is easily damaged. If the damage causes the metal to be exposed, leakage may occur. Handle the gasket carefully.
- A Kammprofile gasket clad with expanded graphite cannot be used with the fluids shown in the table at right, as a general rule.

Fluids for which a Kammprofile gasket (clad with expanded graphite) is not suitable.

Classification	Name of fluid
Oxidizing acid	Nitric acid, concentrated sulfuric acid, hot sulfuric acid, chromic acid, mixed acid, etc.
Oxidizing salt	Nitrate, chloride, hypochlorite, etc.
Halogen compound	Bromine, fluorine, iodine, chlorine dioxide, etc.
Combustible gas	Oxygen (pure oxygen)

Shapes of gaskets for heat exchangers

Nichias can manufacture semi-metal gaskets that are suitable for various heat exchangers. They are used in a wide range of applications.

When placing an order, please specify the desired shape using the corresponding symbol shown below, or a drawing.

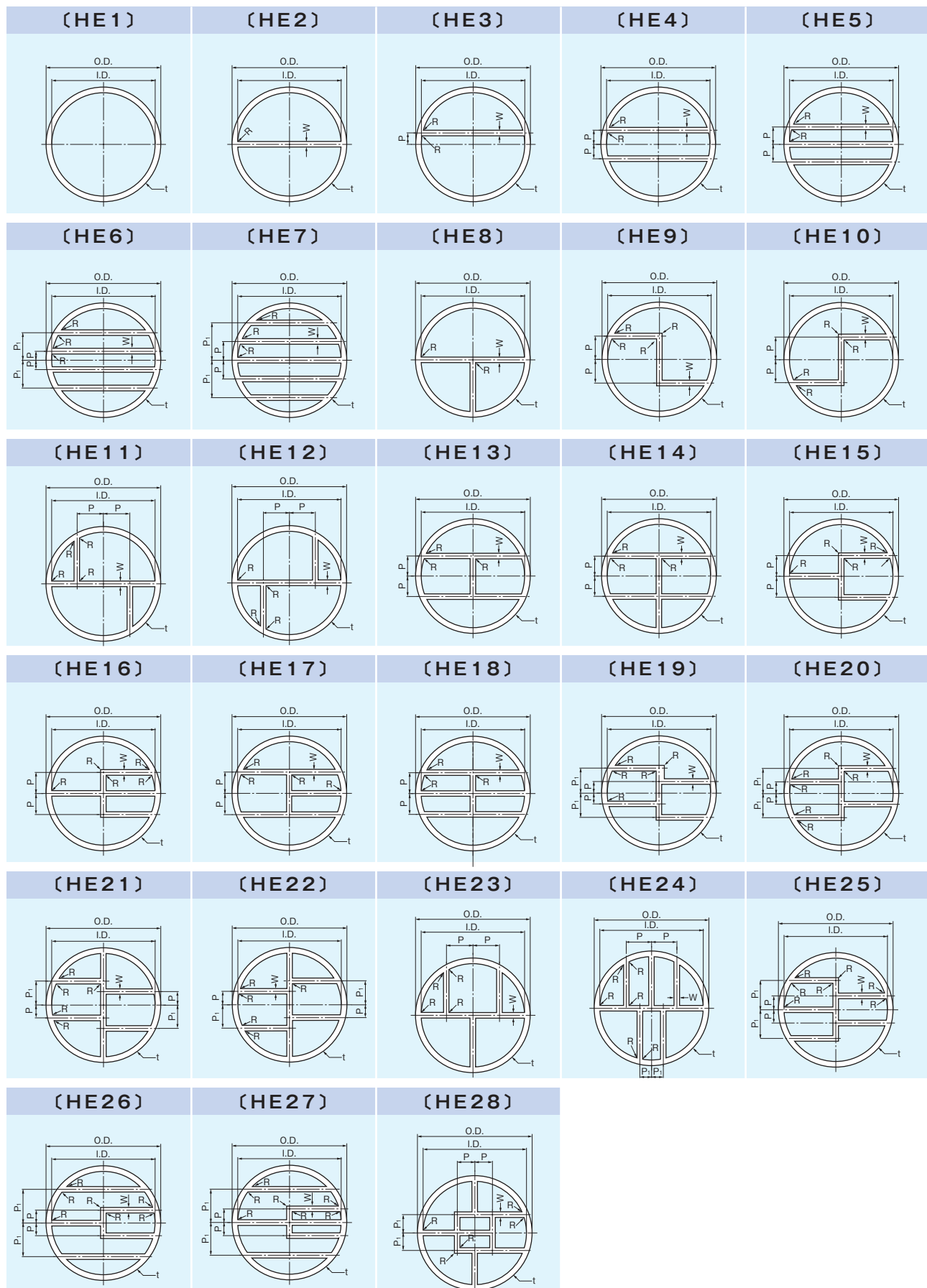



Vortex™ gaskets

For details of the design criteria and the standard dimensions, see P.42.

For handling precautions, see P.45.

Lineup

Nichias Vortex gaskets are available in the following special shapes, in addition to the basic type gaskets and gaskets with inner and outer rings.

Inner ring rod type

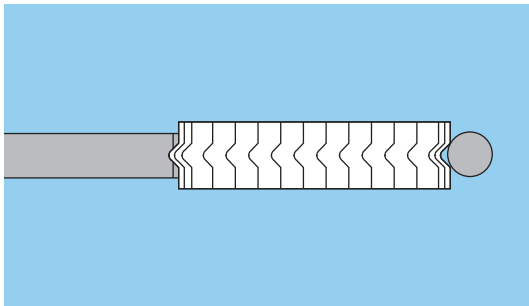

- This type of gasket has a metal rod installed at the I.D. side. It is intended to be used in a place where the width of the necessary inner ring is narrow.
- When the bore is large, this gasket is liable to buckle. TOMBO No.1891 (Kammprofile gasket) is recommended.

Gasket thickness*1	4.5mm
Rod diameter	φ3.2mm
Standard material	304 steel, 316 steel

* 1 : This gasket is available only in a thickness of 4.5mm, as a general rule.

Wound metal hoop type

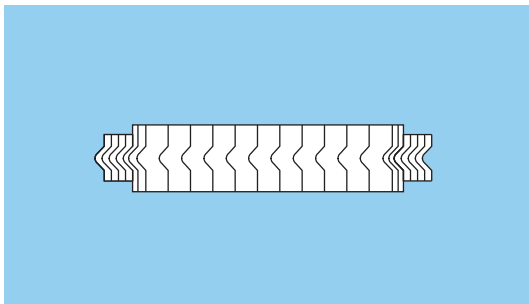

- This gasket has a 3.2mm winding metal hoop at the I.D. side or the O.D. side.
- This gasket is used on an M&F type or T&G type the flanges of which have insufficient width to permit the use of an outer ring.
- The winding metal part does not have the same degree of strength as the inner ring or outer ring, so this type of gasket is not suitable for an FF or an RF type flange.

Gasket thickness*1	4.5mm	
Wound metal part	Thickness	3.2mm
	Maximum width	3.0mm

* 1 : This gasket is available only in a thickness of 4.5mm, as a general rule.

〈Effectiveness of winding metal〉

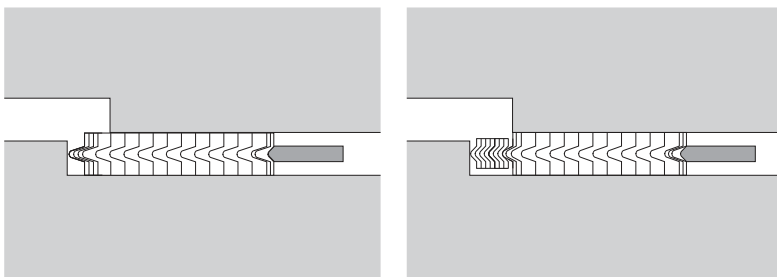

When the gasket main body has moved from the seat

When the wound metal hoop type is used

In the case of an M&F or T&G flange, if the clearance between the tongue and the groove is large, the main body of the gasket may slip off the flange seat as shown in the figure at left, resulting in possible leakage. When a wound metal hoop type gasket is used, the winding metal part functions to prevent centering and abnormal deformation to the O.D. side. It thus eliminates the risk of the main body slipping off the seat.

Branched type for heat exchanger

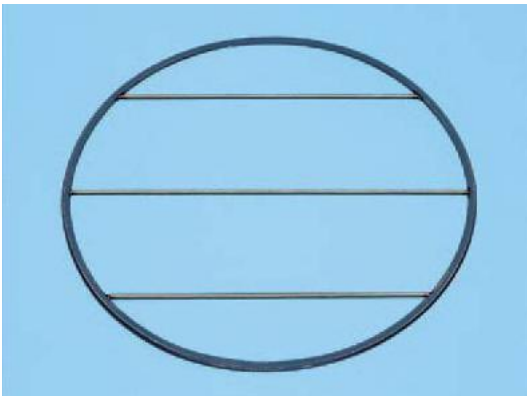

- This type of gasket can be made to any desired shape. It is suitable for use in multipath type heat exchangers.

Types of gasket body	NA vortex™, GRASEAL™ vortex™, NAFLON™ vortex™		
Kind of branch (For a thickness of 4.5mm)	Metal O seal	Material	321 steel
		Dimensions	4.8 (pipe diameter) × 0.5 (wall thickness)
	TOMBO No.1841 (Metal jacket)	Cover metal	Normally, same as the material of the hoop or inner ring
		Standard shape	10 (width) × 4.7 (thickness)

Irregular shaped type



- This type of gasket is used mainly for boiler manholes, hand holes, and valve bonnets.

- When placing an order for a gasket, please specify the dimensions A, B, C, R1, R2, and R3 shown in the diagrams. In the case of a diamond shape, if R3 is a straight line, there is no need to specify R3.
- In the case of an elliptical or track type, dimension A must be at least 40mm. In the case of a diamond type, dimension A must be at least 60mm.
- The ratio A/B must be at least 2/3.
- Because this type of gasket is liable to break up, ensure that the straight part (indicated by ★ in the diagrams below) is no more than 100mm, as a rough guide. If it is necessary to use a straight length of more than 100mm, use TOMBO No.1880-GR (CMGC™ gasket).

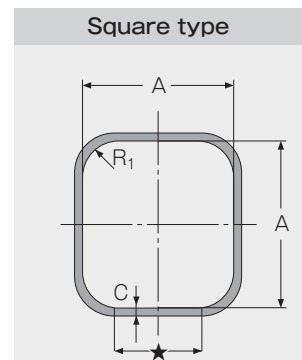
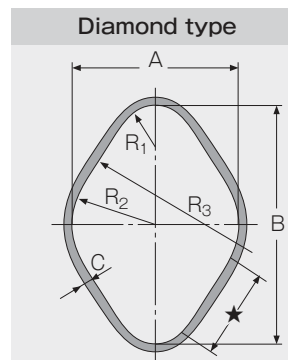
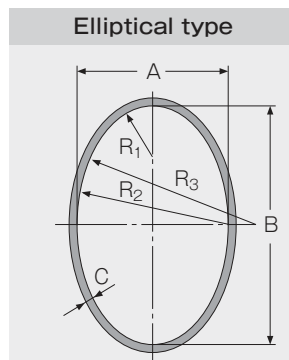
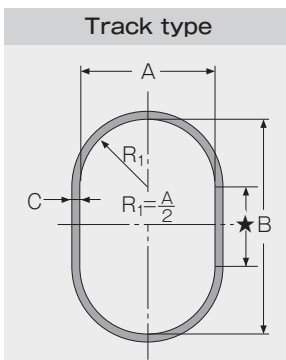

■ How to read TOMBO No. When placing an order, specify the following product specifications (TOMBO No.).

TOMBO No. **1804-EX-GR-000-G**

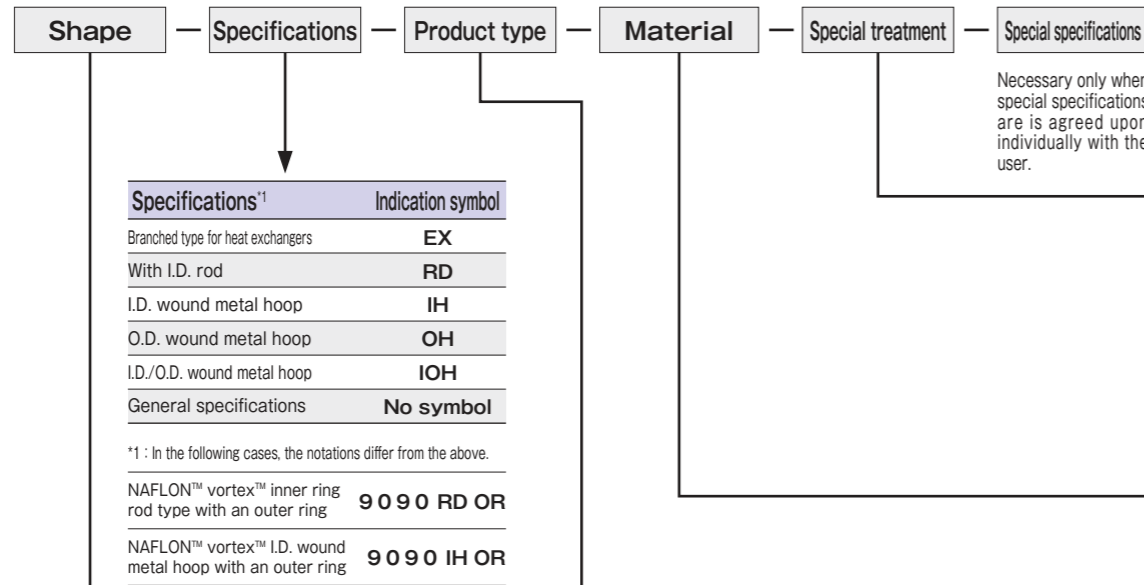

Specifications ¹	Indication symbol
Branched type for heat exchangers	EX
With I.D. rod	RD
I.D. wound metal hoop	IH
O.D. wound metal hoop	OH
I.D./O.D. wound metal hoop	IOH
General specifications	No symbol
*1 : In the following cases, the notations differ from the above.	
NAFLON™ vortex™ inner ring rod type with an outer ring	9090 RD OR
NAFLON™ vortex™ I.D. wound metal hoop with an outer ring	9090 IH OR

Special treatment	Indication symbol
General product	No symbol
Gas-tight treatment	G
Degreasing	K
For oxygen (OX treatment)	OX

* Products that can be subjected to G treatment or K treatment

- GRASEAL™ Vortex™
- GRASEAL™ Vortex™ -L
- GRASEAL™ Vortex™ for aluminum flange

* Products that can be subjected to OX treatment

- OX treatment refers to a gasket that has been degreased and made suitable for oxygen lines in which even a minute amount of oil is not permitted.

Shape	Hoop material	Indication symbol	Type of product	Indication symbol
Basic type	304 steel	1804	GRASEAL™ Vortex™ gasket	GR
	316 steel	1806		
	Other materials	1808		
With inner ring	304 steel	1804 R	NA Vortex™ gasket	NA
	316 steel	1806 R		
	Other materials	1808 R		
With outer ring	304 steel	1834	Vortex™ gasket -GS	GS
	316 steel	1836		
	Other materials	1838		
With inner and outer rings	304 steel	1834 R	Vortex™ gasket -GM	GM
	316 steel	1836 R		
	Other materials	1838 R		
Basic type	304 steel	1804	Vortex™ gasket -GH	GH
	316 steel	1806		
	Other materials	1808		
With inner ring	304 steel	1804 R	Vortex™ gasket -GS	GS
	316 steel	1806 R		
	Other materials	1808 R		
With outer ring	304 steel	1834	Vortex™ gasket -GM	GM
	316 steel	1836		
	Other materials	1838		
With inner and outer rings	304 steel	1834 R	Vortex™ gasket -GH	GH
	316 steel	1836 R		
	Other materials	1838 R		

Shape	Indication symbol	Type of product	Indication symbol
Basic type	1809	GRASEAL™ vortex™ gasket-L	No symbol
With inner ring	1809 R		
With outer ring	1839		
With inner and outer rings	1839 R	GRASEAL™ Vortex™ gasket for aluminum flange	AL

Shape	Indication symbol	Type of product	Indication symbol
Basic type	9090	NAFLON™ Vortex™ gasket	No symbol
With inner ring	9090 -IR		
With outer ring	9090 -OR		
With inner and outer rings	9090 -IOR		

Material	Material	Material
Hoop material Indication symbol	Inner ring material (rod and wound metal materials)* Indication symbol	Outer ring material (wound metal material) Indication symbol
	None O	None O
304 steel E	304 steel E	304 steel E
316 steel G	316 steel G	316 steel G
316L steel H	316L steel H	316L steel H
321 steel J	321 steel J	321 steel J
Titanium T	Titanium T	Titanium T
304L steel L	304L steel L	304L steel L
309S + Cb steel W	309S + Cb steel W	309S + Cb steel W
316ELC steel X	316ELC steel X	316ELC steel X
347 steel K	347 steel K	347 steel K
Inconel 600 Y	Inconel 600 Y	Inconel 600 Y
Monel M	Monel M	Monel M
Nickel N	—	—
310S steel V	—	—
410 steel R	410 steel R	410 steel R
—	430 steel U	430 steel U
—	Carbon steel S	Carbon steel S
Others Z	Others Z	Others Z

...Standard materials of TOMBO No.1804-GR series (GRASEAL VORTEX).
Materials not specified as standard or not listed here may be used under special individual specifications. Please contact us for details. In such a case, use the symbol "Z" and indicate the material name.

*1: In the case of a gasket with an I.D. rod (RD), indicate the rod material. In the case of a wound metal hoop type (IH, OH, IOH), indicate the material of the wound metal hoop. In the case of IOH, specify the material in the sequence I.D. wound metal followed by O.D. wound metal.

■ Examples of TOMBO No.

1806-GR-GOO

■ Shape ■ Product type ■ Hoop material ■ Inner ring material ■ Outer ring material
Basic type GRASEAL™ Vortex™ 316 steel None None

1834-NA-EOS

■ Shape ■ Product type ■ Hoop material ■ Inner ring material ■ Outer ring material
With outer ring NA Vortex™ 304 steel None Carbon steel

9090-IOR-TTG

■ Shape ■ Type of product ■ Hoop material ■ Inner ring material ■ Outer ring material
With inner and outer rings NAFLON™ Vortex™ Titanium Titanium 316 steel

1838-IH-GR-ZZZ

■ Shape ■ Specifications ■ Product type ■ Hoop material ■ Inner ring material ■ Outer ring material
With outer ring I.D.wound metal hoop GRASEAL™ Vortex™ Others*1 Others*1 Others*1

*1: In the case of "Others", specify the material name.

■ Recommended service temperature for material^{1,2} and applicable standards

Material	Recommended service temperature	Applicable standards
Carbon steel	—	JIS G 3141 SPCC JIS G 3131 SPHC ASTM A285 Grade-C SNI-07-0601-BJPC (Indonesian standard)
304 steel	500°C max	JIS G4305 SUS304 ASTM A240 TYPE304
304L steel	500°C max	JIS G4305 SUS304L ASTM A240 TYPE304L
309S + Cb steel	—	AICI 309S+Cb
316 steel	600°C max	JIS G4305 SUS316 ASTM A240 TYPE316
326 steel	600°C max	JIS G4305 SUS316L ASTM A240 TYPE316L
316ELC steel	—	AISI 316ELC (Corresponds to JIS G4305 SUS316L and C content of 0.025% max.)
310S steel	—	JIS G4305 SUS310S ASTM A240 TYPE310S
347 steel	750°C max	JIS G4305 SUS347 ASTM A240 TYPE347
Inconel 600	800°C max	JIS G 4902 NCF600
Monel metal	750°C max	JIS H 4551 NcuP
Titanium	500°C max	JIS H 4600 Type 2 TR340C
321 steel	750°C max	JIS G4305 SUS321 ASTM A240 TYPE321

²: Recommended service temperature as hoop material

[Reference: Old material symbol]

Carbon steel SS	316L steel 316L	430 steel 430
304 steel 304	316ELC steel 316ELC	Inconel 600 Y
304L steel 304L	321 steel 321	Monel M
309S + Cb steel 309S+CB	347 steel 347	Titanium T
316 steel 316	410 steel 410	Others —

■ Design criteria

TOMBO No. ^{*1}	1804-GR	1804-NA	9090	1806-GS -GM, -GH	1809 1809-A L	
Gasket coefficient m [-]	3.00				3.00	
Minimum design seating stress γ [N/mm ²]	68.9				58.8	
Minimum seating stress σ_3 [N/mm ²]	Water-type and oil-type fluids	29.4	34.3	29.4	34.3	—
	Gas-type fluids	39.2	78.4	39.2	78.4	Class150 29.4
						Class300 39.2
Class600 49.0						
Allowable seating stress [N/mm ²]	294.2				294.2	

*1 : Indicates the TOMBO No. for the basic type.

■ Standard dimensions

Gasket thickness [mm] ^{*1}	Inner and outer ring thickness [mm]		Recommended I.D. ^{*2} [mm]	
	Carbon steel	Other than carbon steel	Min.	Max.
3.2	2.0	2.0	φ 16	φ 600
4.5 (Standard)	3.2	3.0	φ 16	φ 3000
6.4	4.5	4.0	φ 1500	φ 3000

*1 : When this gasket is to be used as a pipe flange gasket, use a gasket thickness of 4.5mm as a general rule.

*2 : We can also manufacture gaskets to dimensions other than the above. Note, however, that this may result in deformation, warping or breaking up of the gaskets. In addition, the delivery period may be longer than normal due to the custom specifications. Please consult us separately.

■ Recommended width of the main body of the gasket (When the gasket thickness is 4.5mm)

When individually setting the Vortex dimensions, ensure that the width of the main body of the gasket is the recommended minimum width indicated in the minimum diagram below.

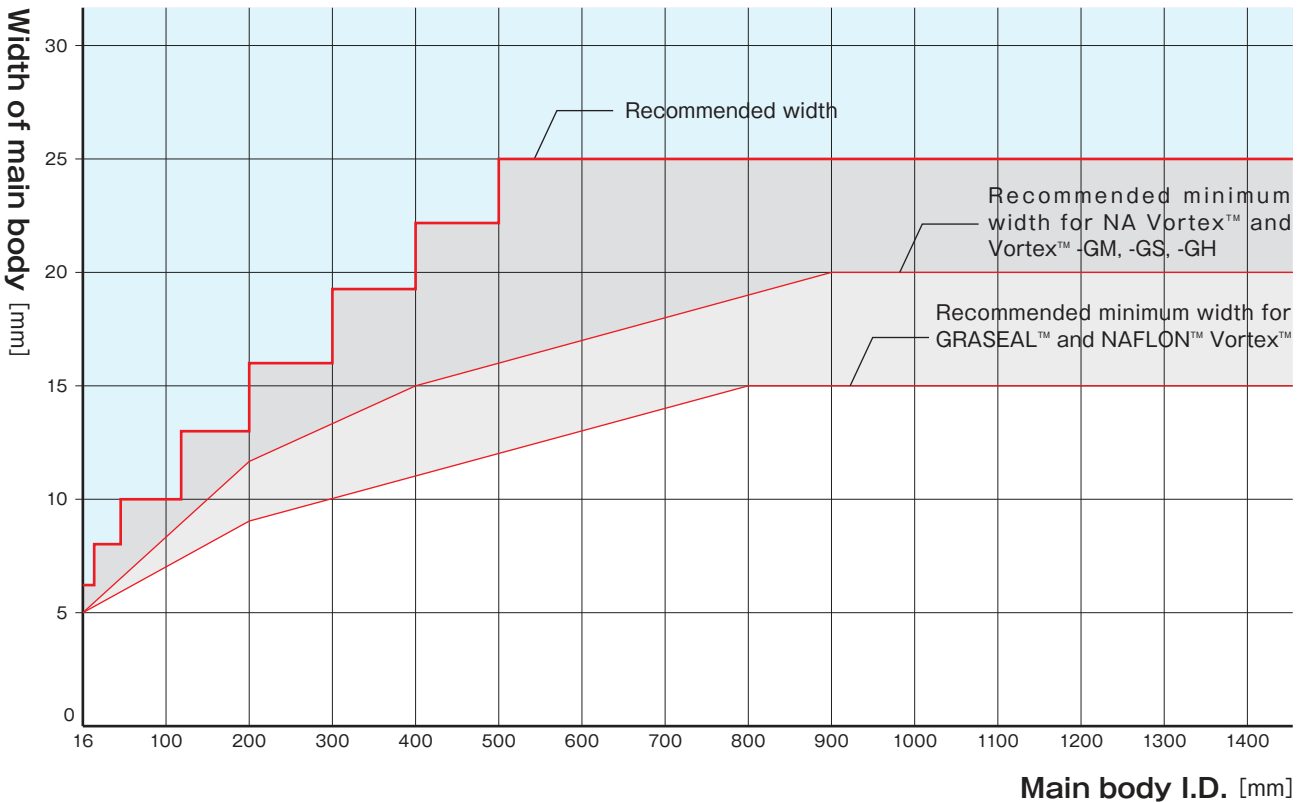

Available range of gasket widths

Main body I.D. Inner ring I.D. Outer ring I.D. [mm]	Range of available main body widths [mm]			Minimum available width of inner ring [mm]	Minimum available width of outer ring [mm]
	Main body thickness: 3.2	Main body thickness: 4.5	Main body thickness: 6.4		
16 ~ 30	4.0 ~ 10	4.5 ~ 10	—	2.5	—
31 ~ 46	4.0 ~ 15	4.5 ~ 15	—	2.5	4
47 ~ 55	4.0 ~ 20	4.5 ~ 20	—	3	4
56 ~ 70	4.0 ~ 22	4.5 ~ 25	—	3	4
71 ~ 90	4.0 ~ 22	4.5 ~ 30	—	3.5	4
91 ~ 110	4.5 ~ 22	5.0 ~ 35	—	3.5	4
111 ~ 150	4.5 ~ 22	5.0 ~ 35	—	4	4
151 ~ 170	4.5 ~ 22	5.0 ~ 40	—	4	4.5
171 ~ 200	4.5 ~ 20	5.0 ~ 40	—	4	4.5
201 ~ 300	4.5 ~ 20	5.0 ~ 40	—	4.5	4.5
301 ~ 400	4.5 ~ 18	5.0 ~ 40	—	5	5
401 ~ 500	5.0 ~ 18	5.5 ~ 40	—	5.5	5.5
501 ~ 600	5.5 ~ 15	6.0 ~ 35	—	6	6
601 ~ 700	—	6.5 ~ 35	—	7	7
701 ~ 800	—	7.0 ~ 35	—	8	8
801 ~ 900	—	7.5 ~ 35	—	9	9
901 ~ 1000	—	8.0 ~ 30	—	10	10
1001 ~ 1100	—	8.5 ~ 30	—	11	11
1101 ~ 1200	—	9.0 ~ 30	—	11	12
1201 ~ 1300	—	10.0 ~ 27 (25)	—	11	13
1301 ~ 1400	—	11.0 ~ 27 (25)	—	11	14
1401 ~ 1500	—	12.0 ~ 27 (25)	—	11	15
1501 ~ 1600	—	(12) ~ 27 (25)	(12) ~ 30	15	16
1601 ~ 1700	—	(12) ~ 25 (22)	(12) ~ 30	15	17
1701 ~ 1800	—	(12) ~ 25 (22)	(12) ~ 30	15	18
1801 ~ 1900	—	(12) ~ 25 (22)	(12) ~ 30	15	19
1901 ~ 2000	—	(12) ~ 25 (22)	(12) ~ 30	20	20
2001 ~ 2100	—	(12) ~ 22 (20)	(12) ~ 30	20	20
2101 ~ 2200	—	(12) ~ 20	(12) ~ 30	20	20
2201 ~ 2300	—	(12) ~ 20	(12) ~ 25	20	20
2301 ~ 2500	—	(12) ~ 18	(12) ~ 25	20	20
2501 ~ 2800	—	—	(12) ~ 22	20	20
2801 ~ 3000	—	—	(12) ~ 20	20	20

* We can also manufacture gaskets to dimensions other than the above. Note, however, that this may result in deformation, warping or breaking up of the gaskets, and also the delivery period may be longer than normal due to the custom specifications. Please consult us for details.

* The numbers in parenthesis are reference values.

* The numbers in the above table are for gaskets with expanded graphite filler. The numbers in [] are for gaskets with PTFE filler and a titanium hoop.

* The thickness of TOMBO No.1809, 1809-AL or an irregular shaped Vortex™ gasket is limited to 4.5mm only, as a general rule.

* The maximum available size of TOMBO No.1809 is ϕ 1200, and that of TOMBO No.1809AL is ϕ 600. If you require a larger size, please consult us.

■ Design guidelines concerning the standard clearance and appropriate groove depth

(Tongue and groove (T&G) type or male and female (M&F) type flange)

● Gasket clearance

Main body of gasket [mm]	Standard clearance [mm]	
	(a)	(b)
250 or less	0.5	0.5
251 ~ 630	0.7	0.7
631 ~ 1600	1.0	1.0
1601 or more	1.5	1.5

● Groove depth

Gasket thickness [mm]	Appropriate groove depth (f) [mm]
3.2	3.5 min.
4.5	5.0 min.
6.4	7.0 min.

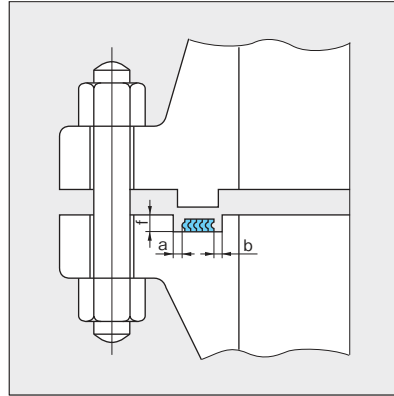

When used in a tongue and groove type flange

(Face and groove (F&G) type flange)

● Gasket clearance

The clearance (b) differs according to the gasket seating stress. Please consult us for details.

● Groove depth

Gasket thickness [mm]	Appropriate groove depth (f) [mm]
3.2	2.4 (+0.1, -0)
4.5	3.2 (+0.1, -0)
6.4	—

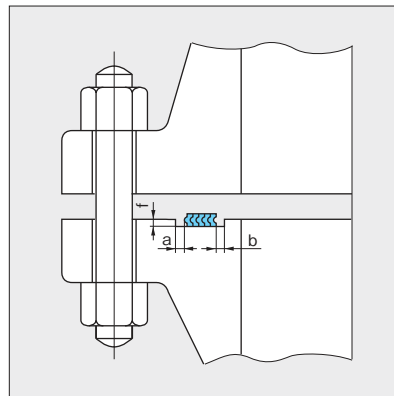

When used in a face and groove type flange

■ Flange seat type and appropriate gasket shape

Flange seat type	Full Face (FF)	Raised Face (RF)	Male and Female (M&F)	Tongue and Groove (T&G)
Applicable shape	With inner and outer rings	With inner and outer rings	With inner ring	Basic type

* A Vortex™ gasket requires a larger tightening force compared to a soft gasket, so it cannot be used on a flange for low pressure (JIS 2K, 5K, vacuum flange, etc.).

* For an aluminum flange, use a TOMBO No.1809-AL series gasket. The use of another Vortex gasket may cause damage to the flange.

* If all of the following conditions are satisfied, the gasket can be used without an inner ring.

- Size (nominal diameter): ϕ 24B or less or 600A or less
- Pressure rating: Class 600 or less or 40K or less
- NA Vortex gasket

⚠️ Precautions for Vortex™ gaskets

■ Precautions concerning design and selection

● Finish of the gasket seat

The recommended surface roughness of the seat of a Vortex gasket is as follows.

- For sealing liquid: 6.3 μm Ra max.
- For sealing gas: 3.2 μm Ra max.

● Bolt material

A Vortex gasket necessitates a larger tightening force compared to a soft gasket. The use of high tension bolts made of SNB7 or higher, is recommended.

● Shape of Vortex™

The inner ring functions to prevent buckling of the seat of the main body of the gasket, maintain high tightening force, and prevent the gasket from breaking (breaking up), in order to prevent deformation of the main body of the gasket to the I.D. side when the gasket is tightened. Be sure to select a type with an inner ring if it is to be installed onto a flange that is unconstrained on the I.D. side, and also in the following cases.

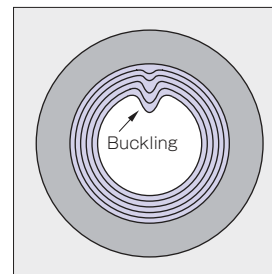

- If the filler used has a low friction coefficient, like GRASEAL and NAFLON
- When the pressure rating of the flange is Class 900 {63K} or higher
- When the nominal diameter of the flange is 650A {26B} or larger

● Recommended gaskets for various kinds of fluids

Fluid	Precautions	Recommended gaskets
Combustible gas	Do not use a GRASEAL Vortex or NA Vortex gasket. There is a possibility of loss of GRASEAL and the organic component of the NA filler due to oxidation.	● NAFLON Vortex for oxygen (TOMBO No.9090-OX series)
Strongly oxidizing fluid (oxidizing acids, oxidizing salts, halogen components)	Do not use GRASEAL vortex gaskets. There is a possibility of GRASEAL being oxidized.	● NAFLON VORTEX
High-temperature fluid	Select materials for the hoop and inner ring that withstand the conditions under which the gasket is to be used.	● Vortex gasket -GS, -GM ● Vortex gasket -GH (when the oxidizing strength of the fluid is weak)
Corrosive fluid	Do not use an NA Vortex gasket because the fluid corrodes the filler.	● GRASEAL Vortex, NAFLON Vortex (Select materials for the inner and outer rings and hoop that can withstand the fluid.)

■ Precautions for use

● Before installation

- Before installing a gasket, clean the flange face and confirm that it is free of foreign matter and damage.
- Handle a gasket with care. Particularly, note that a large bore gasket is liable to break (break up), so have several persons handle it carefully.
- Place a gasket in a suitable position so that it does not shift to one side of the flange.
- There is no need to apply gasket paste, as a general rule. However, if it is considered particularly necessary and also the temperature is no higher than 300°C, apply No.9400 (NAFLON paste).
- You cannot reuse a gasket.

● When using a basic type of Vortex™ gasket

A basic type vortex gasket (including an irregularly shaped gasket) may deform under a very small force, so be very careful when installing it. Note that even if the gasket becomes slightly deformed, it may be possible to insert it into the flange groove and use it as it is, so please consult us.

Applicable standards

- JIS F 0602
"Shipbuilding - Non-asbestos gaskets to cargo piping system - Application standard"
(HUC TOMBO No.1834-NA, HUD TOMBO No.1834R-NA
KUD TOMBO No.1834R-GR, FUC TOMBO No.9090-IOR)
- JIS F 7102
"Standard for Using Gaskets and Packing for Pipes in Marine Engines"
(HUC TOMBO No.1834-NA, HUD TOMBO No.1834R-NA
KUD TOMBO No.1834R-GR)
- JPI-7S-41 "Vortex Type Gaskets for Piping"
(TOMBO No.1804-GR series, TOMBO No.9090 series)
- ASME B16.20
[METALLIC GASKETS FOR PIPE FLANGES, RING JOINT,
SPIRAL-WOUND, AND JACKETED]
- API 601(former)
METALLIC GASKETS FOR RAISED FACE PIPE
FLANGES AND FLANGED CONNECTIONS
(DOUBLE JACKETED CORRUGATED AND SPIRAL-WOUND)
- BS 3381
METALLIC SPIRAL-WOUND GASKETS FOR
USE WITH FLANGES TO BS 1560, PARTS 1 AND 2
- ISO 7483
DIMENSIONS OF GASKETS FOR USE WITH FLANGES
TO ISO 7005



TOMBO No. 1841 / 1861

Metal jacketed gaskets

Lineup

Flat type

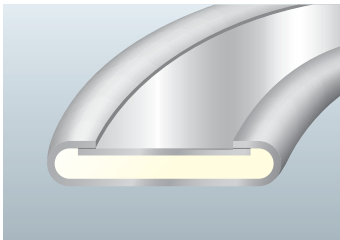

TOMBO No. **1841**

NA metal jacketed gasket

Core material : Millboard

TOMBO No. **1841-FI**

NA metal jacketed gasket for high temperature

Core material : Millboard for high temperature

TOMBO No. **1841-GR**

GR metal jacketed gasket

Core material : Expanded graphite

Corrugated type

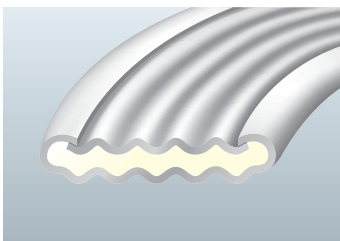

TOMBO No. **1861**

NA corrugated metal jacketed gasket

Core material : Millboard

TOMBO No. **1861-FI**

NA corrugated metal jacketed gasket for high temperature

Core material : Millboard for high temperature

TOMBO No. **1861-GR**

GR corrugated metal jacketed gasket

Core material : Expanded graphite

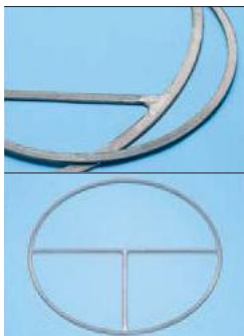

Metal jacketed gasket with GRASEAL™ tape

This is a metal jacketed gasket with GRASEAL™ (expanded graphite) tape applied to the seal face. (Maximum service temperature: 400°C)

Metal jacketed gasket for heat exchangers

This type of gasket can be manufactured to any desired shape for use in a heat exchanger. Install the gasket in such a way that the face with the turned edges touches the bottom of the groove in the flange.

How to read TOMBO No.

When placing an order, indicate the required product specifications (TOMBO No.) from those set out below.

TOMBO No. **1841** — **FI** — **S** — **GR**

Shape of outer skin — Core material — Metal jacket material — Surface material

Shape of outer skin	Indication symbol
Flat	1841
Corrugated	1861

Core material	Indication symbol
NA sheet	No indication symbol
FF sheet	FI
Expanded graphite	GR

Metal jacket material	Indication symbol
Carbon steel	S
304 steel	E
316 steel	G
310S steel	V
Aluminum	A
Copper	C
Monel	M
Other than the above	Z

Surface material	Indication symbol
Expanded graphite	GR
None	No indication symbol

* Shown at left are the standard materials for cover metal. We can manufacture from other metals according to your specifications.

Maximum service temperature

Different core materials	Maximum service temperature
Millboard	530
Millboard for high-temperature	1300
Expanded graphite	400

Cover metal	Maximum service temperature
Carbon steel	535
304 steel	800
316 steel	800
Copper	400
Aluminum	400
310S steel	1150
Monel	800

* Be sure to check the heat-resisting property of both the core material and the cover metal material.

Design criteria

TOMBO No.	1841-S	1841-E, 1841-G, others	1841-C	1841-A	1861-S	1861-E, 1861-G, others	1861-C	1861-A
Cover metal material	Carbon steel	304 steel, 316 steel, others	Copper	Aluminum	Carbon steel	304 steel, 316 steel, others	Copper	Aluminum
Gasket coefficient m [-]	3.75	3.75	3.50	3.25	3.00	3.50	3.25	2.50
Minimum design seating stress y [N/mm ²]	52.4	62.1	44.8	38.0	31.0	44.8	38.0	20.0
Minimum seating stress σ_3 [N/mm ²]	Water-type and oil-type fluids	39.2	49.0	34.3	29.4	—	—	—
	Gas-type fluids	101.4	120.4	76.2	58.8	—	—	—

Standard dimensions

Metal jacket material	Carbon steel	304 steel	316 steel	Copper	Aluminum	310S steel
Material symbol	S	E	G	C	A	V
Standard dimensions [mm]	1480	1180	1180	1180	980	1180

* Indicates the largest diameter of gasket that can be made using a single metal sheet. If a larger gasket is necessary, we will make it by welding two or more metal sheets together.

⚠ Precautions for metal jacketed gasket

Precautions concerning design and selection

● Finish of the gasket seat

The recommended surface roughness when using a metal jacketed gasket is as follows.

- For sealing liquid: 3.2 μm Ra max.
- For sealing gas: 1.6 μm Ra max.

● For 400°C or lower

The sealing face of a metal jacketed gasket is made of metal. If the service temperature is 400°C or lower, the use of the TOMBO No.1891 (kammprofile gasket) which realizes a good fit with the flange and ensures a stable seal is recommended.

● For a standard flange

A standard pipe flange cannot readily acquire adequate tightening force, so the use of a metal jacketed gasket is not recommended. If it necessary to use a metal jacketed gasket, the use of one with a hanger rather than a self-centering type is recommended.

Precautions for use

- When using a metal jacketed gasket for a gas-type fluid, use it together with GRASEAL™ (expanded graphite) tape or gasket paste (Never-Seez™ (service temperature range: -183 to 1425°C), etc.).
- When using a metal jacketed gasket with a T&G type flange, install the gasket so that the face with the turned edges is at the inside of the groove.

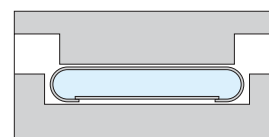

Reference standard

■ ASME B16.20

[Metallic Gaskets for Pipe Flanges-Ring-Joint, Spiral-Wound, and Jacketed]
(TOMBO No.1850C, TOMBO No.1850V)



Comparison of metal gaskets

Product name

Construction

Features

Applications

Service range

TOMBO No.

1850C

Octagonal ring joint gasket



This gasket is made of forged metal that is formed into an octagonal cross-section.

- The surface-to-surface contact of the gasket sealing face and the flange groove realizes excellent sealing performance.
- The gasket can be reused by re-grinding^{*1}.

*1: This involves rubbing the metal surfaces against each other in order to obtain smoother surfaces.

This type of gasket is suitable for sealing pipe flanges, valves, pressure vessels, and heat exchangers, etc., under high-temperature and high-pressure, which is difficult to realize with a plain type metal gasket.

Depends upon the material.

TOMBO No.

1850V

Oval type ring joint gasket



This gasket is made of forged metal formed into an oval cross-section.

- Compared to an octagonal type, the sealing face of this type of gasket touches the flange along a line, thus realizing a good fit with the flange groove. On the other hand, the ring cannot be reused.

This type of gasket is suitable for flange faces on which an octagonal type gasket cannot be used, and also pipe flanges, valves, pressure vessels, heat exchangers, and other applications where fit is important.

Depends upon the material.

TOMBO No.

1850P

Flat type metal gasket

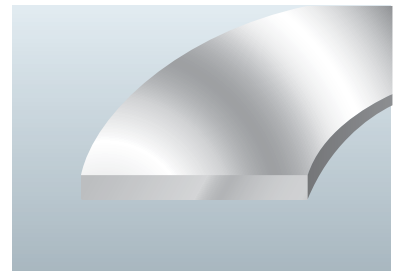

This is a flat gasket that is cut out from a flat sheet, circular rod, or a forged part, and shaped using a lathe.

- Flat type gasket made by flat-forming metal.
- A high tightening pressure is necessary to ensure a good fit between the seal face and the flange.

Pipe flanges, valves, pressure vessels, heat exchangers and other places under high-temperature and high-pressure where the flange cannot be formed to the designated shape.

Depends upon the material.

These gaskets, which are made of various kinds of metal, are formed to the necessary shape and dimensions for the intended conditions of use.

TOMBO No.

1890

Serrated type metal gasket

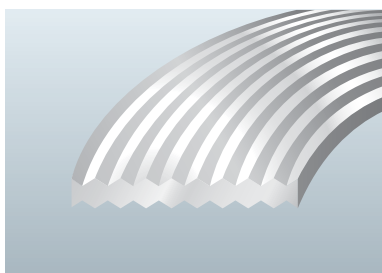

Metal gasket with concentric serrations on its seating faces.

- Compared to a flat type metal gasket, the shape of this gasket results in high sealing performance.
- This gasket can withstand the application of concentrated face pressure. On the other hand, it can sometimes damage the flange.

This gasket is used for pipe flanges, valves, pressure vessels, and heat exchangers, etc., where it is necessary to obtain higher sealing performance than that realized by a flat type gasket under the same tightening force.

Depends upon the material.

TOMBO No.

9200P

Standard type metal O-seal

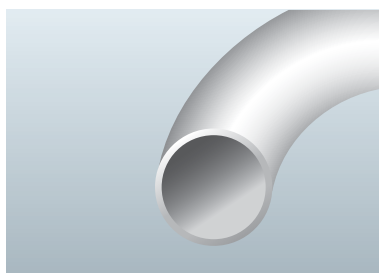

TOMBO No.

9200V

Vent hole type metal O-seal

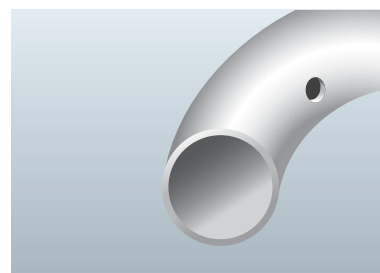

- This gasket is made of a fine metal pipe, which is formed into a circle with its ends welded and its surface finished to a high degree of precision.
- TOMBO 9200V has two or more small holes on its I.D. side (for internal pressure) or O.D. side (for external pressure), through which the fluid enters the ring to increase self-sealing performance.
- This gasket is used by inserting it into a groove and tightening it fully. It can thus provide a high pressure seal with only a small tightening force.

- It has stable, high sealing performance over a wide range of conditions from high temperature to low temperature, and from high pressure to negative pressure.
- When using this gasket in a gas, vacuum or highly volatile fluid, it is recommended that you use a PTFE-coated or silver-plated version.

This gasket is recommended for equipment couplings, forming machines, compression equipment and various engines that necessitate compact design.

- TOMBO No. 9200P...From a vacuum to fluid of about 7.0MPa
- TOMBO No. 9200V...High pressure seal of 7.0MPa or higher

Depends upon the material.

Product name

Construction

Features

Applications

Service range

Metal Gasket



TOMBO No. **1850 series / 1890**

Metal solid gasket

■ **Lineup**

We can manufacture octagonal, oval, plain and serrated gaskets, and also metal gaskets of various shapes.

Shape	Product name	Indication symbol	Features
	RX type ring joint gasket	RX	This is a special octagonal ring joint intended for use on a 6B flange which is stipulated in API spec 6A.
	BX type ring joint gasket	BX	This is a special octagonal ring joint intended for use on a 6BX flange which is stipulated in API spec 6A.
	Delta type metal gasket	D	This is an auto-seal type metal gasket that has a triangular cross-section.
	Lens type metal gasket	L	This is an auto-seal type metal gasket that has a lens-shaped cross-section. It is stipulated in DIN 2696.
	Double cone type metal gasket	No indication symbol	This is an auto-seal type metal gasket the cross section of which is a longitudinally split octagonal ring.
	Bridgeman type metal gasket	No indication symbol	This is an auto-seal type metal gasket which has a wedge-shaped cross-section. It is also called a seal ring.

*For shapes other than the above, please contact us.

■ **How to read TOMBO No.** When placing an order, please specify the following product specifications (TOMBO No.)

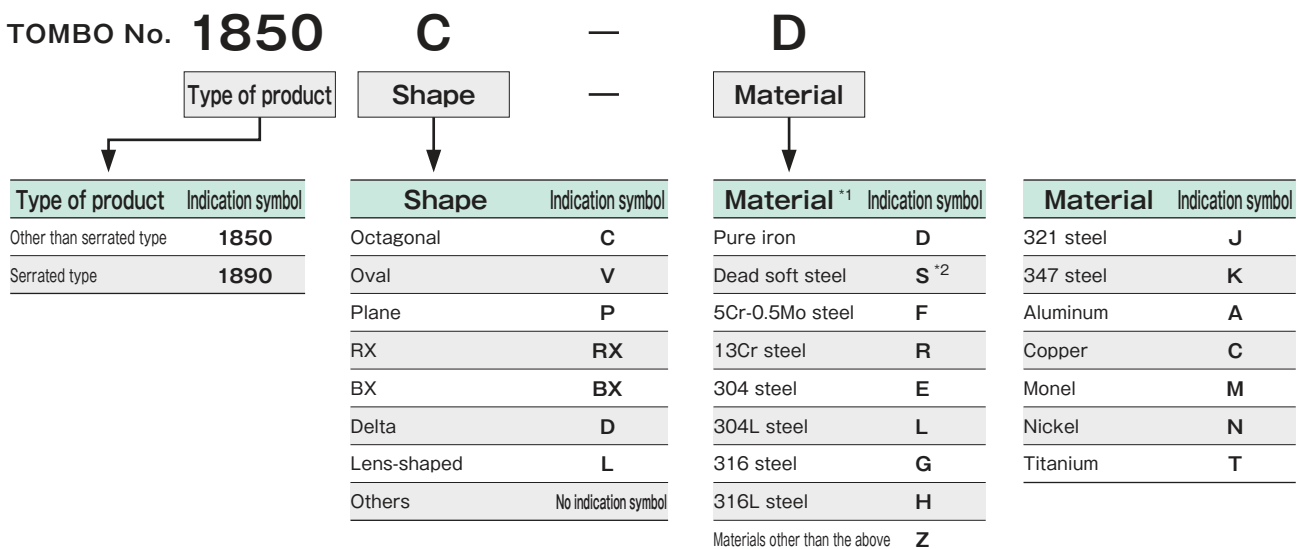

*1: We can manufacture gaskets from other metals according to your specifications. We recommend that you select a gasket that has a Brinell hardness (HB) value of between 30 and 40 softer than that of the flange material.
 *2: A plane metal gasket made from rolled steel is indicated as SS.

■ Type of metal and usable temperature

Material	Material symbol	Max. service temperature [°C]	Max. hardness*2	
			HB	HV
Pure iron	D	538	90	—
Dead soft steel	S *1	538	120	—
5Cr-0.5Mo steel	F	649	130	—
13Cr steel	R	704	170	—
304 steel	E	816	160	—
304L steel	L	816	150	—
316 steel	G	816	160	—
316L steel	H	816	150	—
321 steel	J	816	160	—
347 steel	K	816	160	—
Aluminum	A	300	—	40
Copper	C	400	—	80
Monel	M	800	130	—
Nickel	N	760	120	—
Titanium	T	800	140	—

*1: A plane metal gasket made from rolled steel is indicated as SS.

*2: In the case of TOMBO No.1850P and No.1890, the actual values may differ from those indicated in the table.

*All metal gaskets are made to order. Regarding the possibility of making a gasket from a material other than those listed in this table, please contact us.

■ Finish of the gasket seat

The recommended surface roughness when using a metal solid gasket is as follows.

- For sealing liquid: 1.6 μm Ra max.
- For sealing gas: 1.6 μm Ra max.

Application standards

■ JPI-7S-23

"Ring joint gaskets and grooves for the petroleum industry"
(TOMBO No.1850C, TOMBO No.1850V)

■ ASME B16.20



[Metallic Gaskets for Pipe Flanges-Ring-Joint, Spiral-Would, and Jacketed]
(TOMBO No.1850C, TOMBO No.1850V)

■ API spec 6A

[Wellhead Equipment 6BX Flanges]
(TOMBO No.1850C, 1850RX, 1850BX)

Blinds, spacers, and spectacle blinds

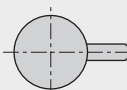
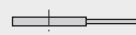
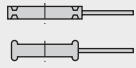
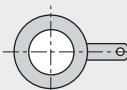
Blinds and spacers are used together with gaskets for blocking pipes or for cutting off pressure during sealing or a pressure resistance test. We also manufacture spectacle blinds which are a combination of a blind and a spacer. In addition, we can also manufacture blinds, spacers and spectacle blinds integrated with ring joint gaskets. Please specify the required material, dimensions, and so on.

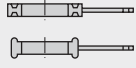
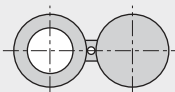
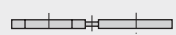
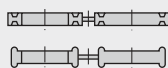
	Shape	RF type	RTJ type
TOMBO No.1850-BL Blind			
TOMBO No.1850-SP Spacer			
TOMBO No.1850-SB Spectacle blind			



TOMBO No. 9200 series

Metal O-seal

The sealing performance of a metal O-seal is realized as the reaction to a compression force. A vent hole type O-seal provides greater sealing performance due to the fluid that enters the hollow part of the ring, so it is recommended that a vent hole type O-seal be used when the pressure is 7 MPa or greater.

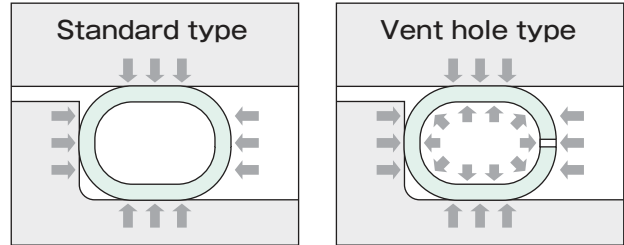

■ **How to read TOMBO No.** When placing an order, indicate the required product specifications (TOMBO No.) from those set out below.

TOMBO No. **9200 P** — **J** — **AG**

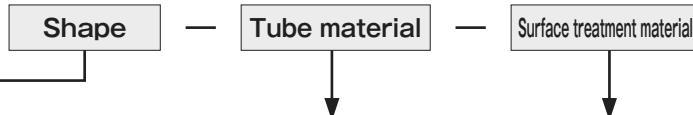

Shape	Indication symbol	Tube material	Indication symbol	Surface treatment material	Indication symbol
Standard type	P	321 steel	J	None	No indication symbol
Vent hole type	V	Inconel 600	Y	Silver plating	AG
				PTFE coating	TF

[Reference: Old material symbol]

321 steel	321
Inconel 600	In
Silver plating	Ag
PTFE coating	TFE

■ Service range

Tube material ^{*1}	Surface treatment ^{*2}	Service temperature range [°C]	Serviceable pressure
321 steel	None	-250~500	High water pressure: 400MPa High-pressure gas: 300MPa Vacuum: 10 ⁻⁴ Pa
	Silver plating	-250~250	
	PTFE coating		
Inconel 600	None	-250~700	
	Silver plating	-250~250	
	PTFE coating		

*1: A metal O-seal can only be made from 321 steel or Inconel 600.

*2: The surface treatment thickness is between 0.03 and 0.05 mm. For sealing a gas, vacuum or volatile fluid, surface treatment is necessary.

■ Tightening criteria

Tube cross-section diameter [mm]	Wall thickness [mm]	Compression load [N/mm]
φ0.8	0.15	69
φ1.6	0.25	118
	0.36	284
φ2.4	0.25	59
	0.46	235
φ3.2	0.25	49
	0.35	88
	0.5	177
φ4.8	0.5	69
	0.8	333
φ6.4	0.8	177

To calculate the actual tightening load, add the load (Wa) of the end force part due to fluid pressure to the load (Wb) calculated from the compression load (Y). The compression load indicates the necessary load for applying the correct tightening force.

■ Calculation of tightening force

$$W = W_a + W_b = \frac{\pi}{4} G^2 P + \pi G Y$$

W: Total bolt load [N]
G: Gasket O.D. [mm]
P: Pressure [MPa]
Y: Compression load [N/mm]

Standard dimensions

Tube cross-section diameter [mm]	Wall thickness [mm]	O.D. dimension [mm]	
		Recommended service range	Manufacturable dimensions
φ0.8	0.15	6 ~ 25	6 ~ 30
φ1.6	0.25	—	10 ~ 200
	0.36	15 ~ 50	11 ~ 200
φ2.4	0.25	—	40 ~ 500
	0.46	40 ~ 200	20 ~ 500
φ3.2	0.25	—	60 ~ 1500
	0.35 *1	—	60 ~ 1500
	0.5	65 ~ 700	50 ~ 1500
φ4.8	0.5 *1	—	150 ~ 1500
	0.8	500 ~ 1200	150 ~ 1500
φ6.4	0.8	1000 ~ 1500	250 ~ 1500 *2

Minimum value of the corner radius in the case of a square gasket

For a standard wall thickness (hatched area)

Radius of I.D. side ≥ 6times the O.D. of the tube

For a wall thickness that is less than the standard wall thickness

Radius of I.D. side ≥ 8times the O.D. of the tube

 Indicates the standard wall thickness. For sealing gas, use the standard wall thickness.

 The minimum O.D. of a vent hole type is φ10mm.

 The maximum O.D. of the PTFE coating is φ1300mm. That of silver plating is φ1100.

*1: The only material that can be used to manufacture a tube is SUS321.

*2: If you wish to use a diameter exceeding 1500mm, please consult us.

Groove dimensions

Tube cross-section diameter [mm]	For an internal pressure seal Groove O.D.*1 [mm]	For an external pressure seal Groove I.D.*1 [mm]	Groove width(W)*1 [mm]		Groove depth(H) [mm]	Groove corner rounding(R) [mm]
			Recommended	Min.		
φ0.8	A +0.35 +0.25	(A-1.6) -0.25 -0.35	1.2 以上	1.1	0.60 ± 0.05	0.2
φ1.6	A +0.40 +0.30	(A-3.2) -0.30 -0.40	2.4 以上	2.0	1.15 ± 0.05	0.3
φ2.4	A +0.40 +0.30	(A-4.8) -0.30 -0.40	3.6 以上	2.9	1.75 ± 0.05	0.5
φ3.2	A +0.50 +0.35	(A-6.4) -0.35 -0.50	4.8 以上	3.7	2.55 ± 0.05	0.8
φ4.8	A +0.50 +0.35	(A-9.6) -0.35 -0.50	7.2 以上	5.6	3.75 ± 0.05	0.8
φ6.4	A +0.55 +0.40	(A-12.8) -0.40 -0.55	9.6 以上	7.5	5.00 ± 0.05	0.8

[A = O.D. of gasket]

*1: In the case of a PTFE-coated or silver-plated gasket, the dimensions of the groove will be changed as follows.

- For an internal pressure seal: 0.1mm will be added to the groove O.D., groove width (W) and the groove depth (H).
- For an external pressure seal: 0.1 mm will be reduced from the groove I.D., and 0.1 mm will be added to the groove width (W) and the groove depth (H).
- If the groove width is narrow, it will be difficult to remove the gasket, so the use of a wide groove width is recommended.

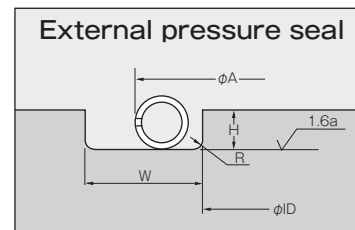
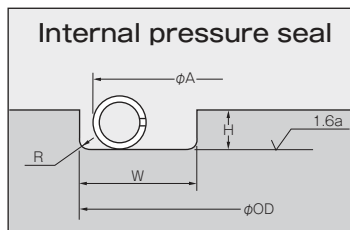

Finish of groove

- For sealing gas or vacuum: 0.8μmRa max.
- In other cases: 1.6μmRa max.



Comparison of rubber gaskets

Product name

TOMBO No.

1050/1051

Rubber cut gaskets



TOMBO No.1050

This gasket is formed by cutting a rubber sheet into the shape of a gasket.

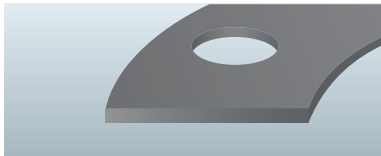

TOMBO No.1051

This gasket is formed by cutting a rubber sheet reinforced with polyester layer into the shape of a gasket.

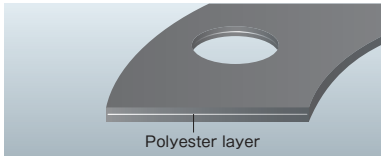

● This gasket utilizes the elasticity, restoring ability and fitting ability of rubber to realize good sealing performance under low contact pressure.

* Because TOMBO No.1051 is reinforced with a polyester layer, the protrusion from the flange is small. However, this gasket is not suitable as a gas seal, because leakage due to permeation is liable to occur.

Service temperature range Depends upon the rubber material.

Maximum service pressure 1.0MPa

TOMBO No.1050

-NBR (nitrile rubber), -CR (chloroprene rubber), -EP (ethylene propylene rubber), -IIR (butyl rubber), -SI (silicone rubber), -FA & -FS (fluorine rubber), -NR (natural rubber), -ZR (hydrogen-added nitrile rubber), -PF (perfluoro rubber)

TOMBO No.1051-NBR,-CR,-NR

For details of the service temperature and standard dimensions, see P.56.

TOMBO No.

9013/9013-D

EBILON™ gasket



Conforms to the Standards and criteria for food and food additives, etc. (3-D-2. Public Notice No. 370 of the Ministry of Health & Welfare, 1959) stipulated by the Food Sanitation Act
* This applies to PTFE film used on the face that is in contact with the fluid.

This gasket consists of a rubber core integrated with a pressurized and heat-formed PTFE film.

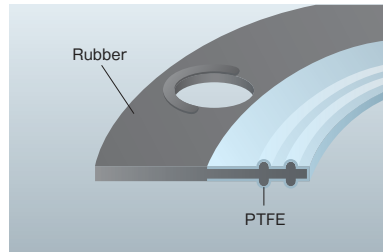

● This gasket combines the elasticity of rubber with the corrosion resistance of PTFE, resulting in excellent sealing performance.

● It is ideal for PVC pipes, glass-lined pipes and other applications where a large tightening force cannot be applied.

Service temperature range -30 - 150°C

Maximum service pressure 2.0MPa

Flange shape Full face

TOMBO No.9013

Consists of EPDM covered with PTFE.

TOMBO No.9013-D

Consists of special EPDM for an electrolytic tank. Covered with PTFE.

TOMBO No.

9013-EP/-DEP

EBILON™ gasket



Rubber gasket pressure-formed to the shape shown below.

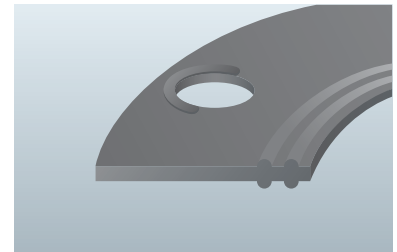

● This gasket realizes stable sealing performance under a lower contact pressure than that of a rubber cut gasket.

* This gasket is recommended for use at places where the service conditions are not harsh, and there is not much need for chemical resistance.

Service temperature range -30 - 150°C

Maximum service pressure 1.0MPa

Flange shape Full face

TOMBO No.9013-EP

EPDM

TOMBO No.9013-DEP

Special EPDM for an electrolytic tank

For details of standard dimensions, see P.56.

Rubber Gaskets

Construction

Features

Service range

Lineup

These gaskets consist mainly of elastic rubber. Consequently, they feature good fit with the flange, even under low tightening face pressure.

TOMBO No.

9014-B/BW

Saniclean™ gaskets for ferrules



 Conforms to the Standards and criteria for food and food additives, etc. (3-D-2, Public Notice No. 370 of the Ministry of Health & Welfare, 1959) stipulated by the Food Sanitation Act
* This applies to PTFE film used on the face that is in contact with the fluid.

This sandwiched type combination gasket is an elastic rubber sanitary gasket covered with PTFE film, realizing excellent resistance against chemicals, heat, and contamination.

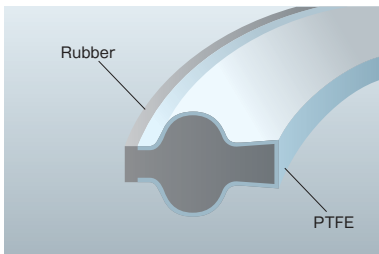

TOMBO No.

9014-A

Saniclean™ gaskets for screw coupling



 Conforms to the Standards and criteria for food and food additives, etc. (3-D-2, Public Notice No. 370 of the Ministry of Health & Welfare, 1959) stipulated by the Food Sanitation Act
* This applies to PTFE film used on the face that is in contact with the fluid.

This sandwiched type combination gasket is an elastic rubber sanitary gasket covered with PTFE film, realizing excellent resistance against chemicals, heat, and contamination.

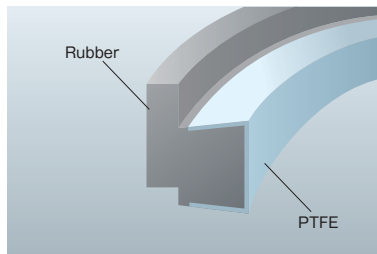

- Because the entire face in contact with the fluid is made of PTFE¹, the surface is not degraded by hot water, hot caustic fluid, or chlorine water used in a sanitation² process.
- Because the entire face in contact with the fluid is made of PTFE, there is little adhesion or penetration of liquid, so these gaskets are effective for preventing contamination of flavor during a flavor change³.
- The use of these gaskets reduces the duration of the sanitation process during a flavor change, contributing to improved productivity.

* The method of using these gaskets is basically the same as that of a conventional rubber sanitary gasket, and is easy, however it is necessary to carry out additional tightening work.

*1: PTFE used on the fluid contact surface of TOMBO No.9014 (Saniclean gasket) has passed the elution test for plastic implement, container and package specified in 3-D-2 of the standard covering foodstuffs and additives, etc.(Public Notice No.370, 1959).

*2: Sanitation: This is cleaning work carried out using tap water, chlorine water, hot water or hot caustic fluid.

*3: Flavor change: This is a change of a production item on a beverage production line, such as a product filler line, which is shared among several kinds of beverages.

Service temperature range -30 - 150°C

Maximum service pressure 1.0MPa

TOMBO™ No.9014-B for ferrule Black EPDM

TOMBO™ No.9014-BW for ferrule White EPDM

For details of standard dimensions, see P.57.

TOMBO No.

2670

Rubber O-rings



Rubber O-rings are manufactured from various rubber elastic bodies using a die.

- These rubber O-rings realize a good fit, even under a small tightening force, and can provide a seal from a vacuum to a high pressure of about 25MPa.
- In addition to their use as shaft seals (packing), these rubber O-rings can be inserted into a groove and used as gaskets.

Service temperature range Depends upon the rubber material.

Maximum service pressure 25MPa

※ These O-rings can also be used at pressures above 25MPa, provided that consideration is given to clearances, backup rings, and so on.

Rubber materials

-NBR (nitrile rubber), -CR (chloroprene rubber), -EP (ethylene propylene rubber), -IIR (butyl rubber), -SI (silicone rubber), -FA & -FS (fluorine rubber), -ZR (hydrogen-added nitrile rubber), -PF (perfluoro rubber), -BNX (Blazer Next)

For details of standard dimensions and basic physical properties, see P.57.

Product name

Construction

Features

Service range

Lineup

Rubber Gaskets



TOMBO No. 1050 / 1051

Rubber cut gaskets

Standard dimensions

Thickness [mm]	Width [mm]	Max. O.D. [mm]
1.0	1,000	φ1,000
1.5		
2.0		
3.0		
5.0		
10.0		

* The maximum O.D. for ZR and PF materials of thickness 1.0mm, 1.5mm, 2.0mm and 3.0mm is φ 300mm.

* The minimum thickness of a cloth-reinforced NR gasket is 1.5mm.

Design standard

TOMBO No.	1050 (HS ^{*1} less than 75)	1050 (HS ^{*1} 75 or more)	1051
Gasket coefficient m [-]	0.50	1.00	1.25
Minimum design seating stress y [N/mm ²]	1.4	1.4	2.8
Minimum seating stress σ _s [N/mm ²]	Water-type and oil-type fluids	1.5	2.0
	Gas-type fluids	2.0	2.9
Allowable seating stress [N/mm ²]	14.7	14.7	14.7

*1: Hardness of rubber (by Type A durometer)

Finish of gasket seat

The recommended surface roughness for a rubber cut gasket is as follows.

- For sealing liquid: 25 μm Ra max.
- For sealing gas: 25 μm RA max.

Standard materials

Material	Material symbol	Service temperature range [°C]	TOMBO No.	
			1050	1051
Nitrile rubber (oil resistant)	NBR	-30 ~ 120	●	●
Chloroprene rubber (weather resistant)	CR	-30 ~ 120	●	●
Ethylene-propylene rubber (weather resistant and vapor resistant)	EP	-40 ~ 150	●	—
Butyl rubber (weather resistant, acid resistant and vapor resistant)	IIR	-30 ~ 150	●	—
Silicone rubber (weather resistant and cold resistant)	SI	-50 ~ 200	●	—
Fluorine rubber (heat resistant)	FA	-15 ~ 200	●	—
Fluoro-nitrile rubber (corrosion resistant)	FS	0 ~ 200	●	—
Natural rubber	NR	-20 ~ 100	●	●
Hydrogen added nitrile rubber (oil resistant)	ZR	-30 ~ 150	●	—
Perfluoro rubber (corrosion resistant)	PF	0 ~ 200	●	—



TOMBO No. 9013 series

EBILON™ gaskets

Standard dimensions

- Plastic flange (equivalent to JIS 10K) 15A to 300A
- JPI class 150 1/2 - 24B

Finish of gasket seat

The recommended surface roughness for an EBILON gasket is as follows.

- For sealing liquid: 25 μm Ra max.
- For sealing gas: 25 μm RA max.

* The surface roughness of the seat on a steel flange is 6.3 μm Ra.



TOMBO No. 9014 series

Saniclean™ gaskets

Standard dimensions

Nominal dimension [inch]	TOMBO No.					
	9014-A (for screw coupling) [mm]			9014-B (for ferrule) [mm]		
	φA	φB	φC	φA	φB	φC
1	32.5	29.2	23.0	49.5	43.5	23.1
1 1/2	46.0	42.7	35.6	49.5	43.5	35.8
2	59.5	56.2	47.8	63.0	56.5	48.0
2 1/2	73.0	69.9	59.5	76.5	70.5	59.7
3	86.5	82.6	72.1	90.0	83.5	72.3
4	112.5	108.3	97.6	118.0	110.0	97.8

* The standard dimensions of TOMBO No.9014-A and B are determined based on the IDF standard. It can also be used for screw couplings and clamp type couplings stipulated by ISO2852 and ISO2853.

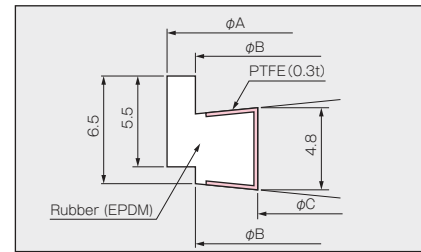

TOMBO No.9014-A (for screw coupling)

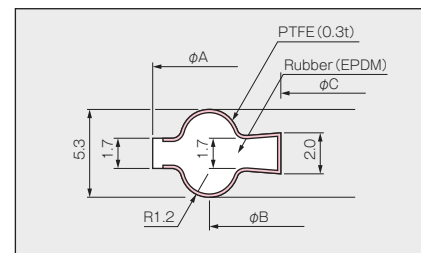

TOMBO No.9014-B and BW (for ferrule)



TOMBO No. 2670

Rubber O-rings

Standard dimensions

- JISB 2401 "O-rings," ●AS 568B "Aerospace size standards for O-rings" ●JIS B 8365 "Dimensions of Clamped-type Vacuum Couplings"

Service temperature and basic physical properties

Product name		Nitrile rubber	Chloroprene rubber	Ethylene-propylene rubber	Silicone rubber	Fluorine rubber FA	Fluorine rubber FB
Material symbol		NBR	CR	EP	SI	FA	FB
Features		Mineral oil-resistant	Weather-resistant and oil-resistant	Weather-resistant and water-resistant	Heat-resistant	Heat-resistant	Acid-resistant and vapor-resistant
JIS class		Class 1A	—	Class 3	Class 4C	Class 4D	—
Color tone		Black	Black	Black	Reddish brown	Black	Black
Service temperature range (rough guide) [°C]		-30~120	-30~120	-40~150	-50~200	-15~200	0~200
Physical properties in normal state	Hardness measured using a type A durometer	73	70	71	72	70	70
	Tensile strength [Mpa]	16.1	11.0	14.8	6.8	13.6	23.9
	Elongation [%]	270	270	250	200	240	320
	Tensile stress [at 100% elongation]	4.2	—	4.6	2.4	4.5	3.1
Compression permanent deformation	Temperature × Time [°C] × [hrs]	120×70	100×70	100×70	175×22	175×22	175×22
	Compression permanent deformation [%]	20	31	9	20	8	20
Aging resistance	Temperature × Time [°C] × [hrs]	120×70	100×70	100×70	230×24	230×24	230×24
	Change of hardness measured using a type A durometer	+1	+9	0	+4	+2	0
	Tensile strength rate of change [%]	+6.5	+16.3	+6.6	-5.9	+12.5	-13
	Elongation rate of change [%]	-25.9	-35	0	0	-16.6	-6

* In addition to the above, butyl rubber (IIR), fluorine rubber (FS), hydrogen added nitrile rubber (ZR), perfluoro rubber (PF), and Blazer next (BNX) are also available.

* The table above indicates the general physical properties of rubber O-rings. For details, please refer to the "Rubber O-rings" catalog.



Comparison of cloth gaskets

These gaskets are not suitable for tight gas seals. Use them in places where a certain amount of leakage is permitted.

Product name

TOMBO No.

1374

NA manhole gasket

TOMBO No.

1400-TH

FF manhole gasket

TOMBO No.

1400-NA/-S

Super manhole series

TOMBO No.

1400-ST

Super manhole series

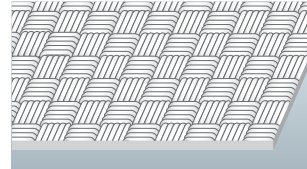

These gaskets consist of heat resistant cloth which is caulked with rubber filler and then cut to the specified shape.

Features

TOMBO No.		1374	1400-TH	1400-NA	1400-ST	1400-S
Cloth construction	Woof	Glass fiber	Ceramic fiber + SUS wire	Ceramic fiber + SUS wire	Ceramic fiber + SUS wire	Ceramic fiber + SUS wire
	Warp	Glass fiber	Ceramic fiber + SUS wire	SUS wire	Ceramic fiber + SUS wire	SUS wire
Heat-resistant temperature [°C]		400	600		800	
Color tone		Gray	Yellow	Black	Yellow	Gray
Smoke emission ^{*1} (quantity of organic matter)		25% or less	20% or less	15% or less	25% or less	15% or less

*1: Differs according to the conditions of use. Carry out an evaluation using an actual machine.

* This is the measured value. It is not a guaranteed value.

Handling

TOMBO No.		1374	1400-TH	1400-NA	1400-ST	1400-S
Hardness/softness	Evaluation	Soft	Soft	Hard	Soft	Soft
	Compression [%] ^{*1}	59	70	34	70	58
Stiffness	Evaluation	Strong	Weak	Very strong	Strong	Strong
	Deflection [mm] ^{*2}	18	36	1	19	15
Tensile strength	Evaluation	Strong	Weak	Very strong	Somewhat weak	Somewhat strong
	Tensile strength ^{*3}	47N	9N	81N	11N	16N

*1: Degree of compression when a contact pressure of 5.9MPa is applied.

*2: Fix a testpiece of 20mm × 200mm at one point, and measure the deflection when the test piece is allowed to droop under its own weight.

*3: Tensile strength per one piece of cloth.

* This is the measured value. It is not a guaranteed value.

Applications

Manholes and hand holes for exhaust gas, hot air passage, etc. Autoclaves and large bore flanges.
Diesel engine exhaust pipe, flue manhole, boiler combustion port.

Lineup

TOMBO No. 1374-G

This gasket consists of TOMBO No.1374 that has been subjected to anti-seizure treatment (graphite treatment). Black.

TOMBO No. 1400-THG

This gasket consists of TOMBO No.1400-TH that has been subjected to anti-seizure treatment (graphite treatment). Black.

TOMBO No.9094 NAFLON™ manhole gasket

This is a manhole gasket that uses PTFE dispersion as the filler material. It is used for the ducts where chemical resistance or solvent resistance is required and the ducts for corrosive gas such as acidic exhaust gas. It withstands a temperature of 300°C. Color: White

Woven gaskets are divided mainly into two types. One is a tape type consisting of woven cloth coated with rubber compound that is folded into several layers and pressed into the form of a tape. The other is a manhole type consisting of woven cloth sewn to fit the shape of the manhole and then formed into a gasket. They are ideal for applications in which the bore of the flange is large, where there is distortion, and also where a high seating stress cannot be applied.

TOMBO No.

1364

NA gasket tape



This gasket tape consists of woven glass cloth coated with natural rubber and folded to form a laminated tape.

3-layer fold

4-layer fold

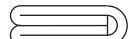
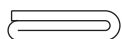

400°C

Gray

Manholes, hand holes, autoclaves and large bore flanges that are exposed to low pressure vapor, exhaust gas, hot air, etc.

TOMBO No.

1368

NA tadpole gasket tape

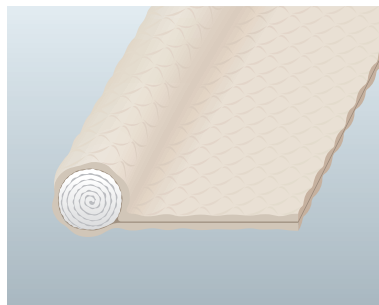

■ TOMBO No.1368 gasket tape has a core of woven glass cloth coated with rubber compound and coiled, and its outer skin is formed as shown in the figure above.

■ TOMBO No.1378 is TOMBO No.1368 that is formed into a ring and sewn into the shape of a gasket.

400°C

Gray

Doors of furnaces, heaters, dryers, etc., dampers, and also manholes for passages of exhaust gas, hot air, dust, etc.

■ TOMBO No.1368-G

This is TOMBO No.1368 subjected to anti-seizure treatment (graphite treatment). Black.

TOMBO No.

1378

NA tadpole gasket



Product name

Series reference

Color tone

Applications

Lineup

Cloth Gasket

Standard dimensions

TOMBO No.		1374 1374-G	1400-TH 1400-THG	1400-ST	1400-NA	1400-S	9094	1364	1368 1368-G	1378	
Nominal thickness	1.6	—	—	—	—	—	●	—	—	—	
	2.5	—	—	●	—	—	—	—	—	—	
	3.0	—	—	—	—	●	—	—	—	—	
	3.2	●	—	—	●	—	●	●	●	●	
	4.0	—	●	—	—	—	—	—	—	—	
	4.8	●	—	—	●	—	●	●	—	—	
	5.0	—	—	●	—	●	—	—	—	—	
	6.0	—	●	—	—	●	—	—	—	—	
	6.4	●	—	—	●	—	●	●	—	—	
	7.5	—	—	●	—	—	—	—	—	—	
	8.0	●	●	—	●	●	—	—	—	—	
	9.6	●	—	—	●	—	—	—	—	—	
10.0	—	●	●	—	●	—	—	—	—		
Dimensions		Please specify.					Please specify.		[Width mm] 13, 20, 25, 30, 40, 50 [Length m]30	[Height mm] 6.4, 7.9, 9.5, 11.1, 12.7, 15.9, 19.1, 22.2, 25.4	Please specify.



Comparison of pastes and other sealing materials

Product name	TOMBO No. 9105 Aqua-tight™ Paste	TOMBO No. 9106 Oil-tight™ Paste	TOMBO No. 9400 NAFLON™ paste
Features	This gasket paste is suitable for a water-type fluid. It consists of fine mica powder blended with a special oil-soluble binder.	This gasket paste is suitable for use with oil-type fluids. It consists of fine mica powder blended with a water-soluble binder which is highly resistant to oil and solvents.	<ul style="list-style-type: none"> This gasket paste, which is inert at normal temperature, consists of a colloidal suspension of fluoro-resin particles dispersed in water. This versatile paste has excellent chemical resistance, and can be used for acidic fluids and corrosive fluids.
Applications	Water-type fluids such as water, steam, hot water, seawater, acids, alkalis, and saline solutions	Petroleum-based oil, oil gas, solvents, solvent vapor, animal and mineral oil, hydrocarbon-based fluids, exhaust gas, etc.	Various water-type fluids, various oil-type fluids, acidic fluids, corrosive fluids, and vacuum seals.
Color	Cream	Cream	White
Service range	-200°C - 200°C	-200°C - 900°C	~ 260°C
Coverage	Approx. 200g/m ² (12.5m ² /can)	Approx. 300g/m ² (8.3m ² /can)	Approx. 50g/m ² (2m ² /tube)
Package	2.5kg polyethylene container	2.5kg polyethylene container	65cc (approx. 100g) tube 700cc (approx. 1kg) polyethylene container

⚠ Precautions for using gasket paste

- Gasket paste is intended to assist the sealing function of a gasket. It is not intended to be used on its own. Be sure to use it by applying it to a gasket.
- Before using gasket paste that comes in a container, agitate it thoroughly.
- Spread gasket paste thinly and apply it using a brush, shop towel, etc. If you apply too much paste, the gasket may become damaged.
- When using gasket paste for the purpose of improving the gas sealing performance of a joint sheet, apply the gasket paste to the I.D. side in order to prevent gas leakage due to penetration.
- Set the gasket on the flange before the gasket paste has completely dried.
- After use, close the container securely and store in a cool and dark location.
- There is a possibility of elution of a minute quantity of paste particles. Do not use gasket paste in applications such as foodstuff where even a minute quantity of elution is not tolerated.

■ Guide to the suitability of gasket paste

Product	TOMBO No. (example)	Gas	Liquid	Applicable paste (TOMBO No.)
Joint sheet	1120	◎	×	9105
	1995	◎	×	9106
				9400
Fluoro-resin gasket	1133	◎	×	9400
GRASEAL™ gasket	1200 series	▲	▲	—
Vortex™ gasket	1834-GR series	×	×	—
	1834R-NA series	×	×	—

◎ Recommended.

▲ When high gas sealing performance is required, use TOMBO No.1215-T.

× Paste is not required. (However, it can be used.)

*On a gasket using expanded graphite, if paste containing metal, such as Never-Seez, is used at high temperature, the expanded graphite may be lost by oxidation due to the catalytic action of the paste components.

TOMBO No.

9401

Fluorine grease



This type of grease consists of fluorine resin oil to which chemically inert highly heat resistant fine powder macromolecular material has been added.

Oxygen, corrosive fluids, vacuum seal

White

~ 150°C

Approx. 50g/m² (1m²/tube)

50g tube

TOMBO No.

9082/9082-BL

NAFLON™ sealing tape



- This product consists of unsintered PTFE that is extruded by an extruder and rolled into the form of tape.
- It is very soft, so it enables a seal of a complicated shape to be easily made. It does not contaminate the fluid, can be removed easily, and has excellent workability.

*When using this tape on a screw coupling, be sure to use it on a tapered thread.

Screw coupling for various fluids other than combustible gases and toxic gases

*Do not use this seal tape for combustible gases or toxic gases.

Standard dimensions

Thickness 0.1mm

Width 13mm

Length 5m / 15m

This tape is wound on a plastic reel. It comes in a box containing 10rolls.

Lineup

TOMBO No.9082

Apparent density[g/cm³] 1.0 or more, but less than 1.4

Tensile strength[N/mm²] 6.9 ~ 15.7

TOMBO No.9082-BL

Apparent density[g/cm³] 0.75 or more, but less than 1.15

Tensile strength[N/mm²] 4.9 ~ 12.7

Application standard

■ JIS K 6885

"Unsintered Polytetrafluoroethylene Tapes for Thread Sealing"
(TOMBO No.9082)

TOMBO No.

1600

META-COAT™



- This gasket consists of a thin metal sheet that is lightly coated on both sides with rubber, and surface-treated with graphite.
- It has good thickness and dimensional accuracy, and there is no substantial leakage.
- The amount of stress reduction is small, so there is no need to perform additional tightening.

Gaskets and sealing washers for hydraulic equipment, pneumatic equipment, equipment related to automobiles, and compressors for chillers

Maximum service temperature

~180°C

LDC
LUAN DUNG

TOMBO™ BRAND GASKETS

Dimension Tables / Basic Items Concerning Gaskets

■ Dimension Tables

Sheet gaskets	64 – 73
Vortex™ gaskets	74 – 89
Metal gaskets	90 – 94
Cushion gaskets	95 – 107
Rubber gaskets	108 – 109

■ Basic Items Concerning Gaskets

Gasket tightening criteria	110 – 111
Introduction of JIS B 2251-2008 Bolt tightening for pressure boundary flanged joint assembly	111
Gasket design criteria list	112 – 113
Gasket standard dimension list	114 – 115

Soft gaskets / ring gaskets (F.R.)

■ Applicable gaskets

Joint seat gaskets, fluororesin gaskets, GRASEAL™ gaskets, cut rubber gaskets, cloth reinforced rubber cut gasket

■ Applicable standards

JIS B 2404-2006 "Dimensions of Gaskets for Use with Pipe Flanges," Appendix Table 4 Dimensions
(Old) JIS B 2238-1996 "General Rules for Steel Pipe Flanges," Reference Tables 2 and 3
(Old) JIS B 2404-1999 "Dimensions of Gaskets for Use with Pipe Flanges," Table 7

■ Applicable flanges

JJIS B 2220-2004 "Steel Pipe Flanges"
(Old) JIS B 2238-1996 "General Rules for Steel Pipe Flanges"
JIS B 2239-2004 "Cast Iron Pipe Flanges"
(Old) JIS B 2240-1996 "General Rules for Copper Alloy Pipe Flanges"
JIS B JIS B 2240-2006 "Copper Alloy Pipe Flanges"
(Old) JIS B 2241-1986 "Basic Dimensions of Aluminium Alloy Pipe Flanges"
JIS B 2241-2006 "Aluminium alloy pipe flanges"

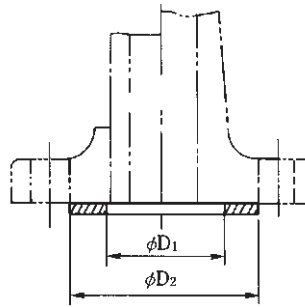

For full-face seat flange

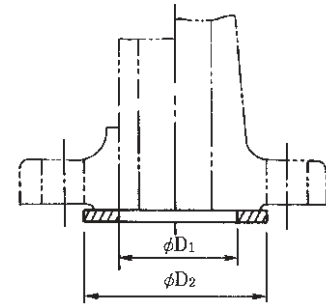

For large flat seat flange

[Dimension Table 1]

Unit [mm]

Nominal flange diameter	I.D. of gasket D ₁	For full-face seat, large flat seat, and small flat seat flanges									
		Gasket O.D. D ₂							Nominal pressure 30K	Nominal pressure 40K	Nominal pressure 63K
		Nominal pressure 2K	Nominal pressure 5K	Nominal pressure 10K	Thin flange nominal pressure 10K	Nominal pressure 16K	Nominal pressure 20K				
10A	18	—	45	53	55	53	53	59	59	64	
15	22	—	50	58	60	58	58	64	64	69	
20	28	—	55	63	65	63	63	69	69	75	
25	35	—	65	74	78	74	74	79	79	80	
32	43	—	78	84	88	84	84	89	89	90	
40	49	—	83	89	93	89	89	100	100	108	
50	61	—	93	104	108	104	104	114	114	125	
65	84 (77)	—	118	124	128	124	124	140	140	153	
80	90	—	129	134	138	140	140	150	150	163	
90	102	—	139	144	148	150	150	163	163	181	
100	115	—	149	159	163	165	165	173	183	196	
125	141	—	184	190	194	203	203	208	226	235	
150	167	—	214	220	224	238	238	251	265	275	
175	192	—	240	245	249	—	—	—	—	—	
200	218	—	260	270	274	283	283	296	315	330	
225	244	—	285	290	294	—	—	—	—	—	
250	270	—	325	333	335	356	356	360	380	394	
300	321	—	370	378	380	406	406	420	434	449	
350	359	—	413	423	425	450	450	465	479	488	
400	410	—	473	486	488	510	510	524	534	548	
450	460	535	533	541	—	575	575	—	—	—	
500	513	585	583	596	—	630	630	—	—	—	
550	564	643	641	650	—	684	684	—	—	—	
600	615	693	691	700	—	734	734	—	—	—	
650	667	748	746	750	—	784	805	—	—	—	
700	718	798	796	810	—	836	855	—	—	—	
750	770	856	850	870	—	896	918	—	—	—	
800	820	906	900	920	—	945	978	—	—	—	
850	872	956	950	970	—	995	1,038	—	—	—	
900	923	1,006	1,000	1,020	—	1,045	1,088	—	—	—	
1,000	1,025	1,106	1,100	1,124	—	1,158	—	—	—	—	
1,100	1,130	1,216	1,210	1,234	—	1,258	—	—	—	—	
1,200	1,230	1,326	1,320	1,344	—	1,368	—	—	—	—	
1,300	1,335	—	—	—	—	1,474	—	—	—	—	
1,350	1,385	1,481	1,475	1,498	—	1,534	—	—	—	—	
1,400	1,435	—	—	—	—	1,584	—	—	—	—	
1,500	1,540	1,636	1,630	1,658	—	1,694	—	—	—	—	

*The dimension in parentheses [] and unstipulated nominal pressure values of 2K, 40K and 63K are the same as those in (Old) JIS B 2238-1996 "General Rules for Steel Pipe Flanges" Reference Tables 2 and 3 and (Old) JIS B 2404-1999 "Dimensions of Gaskets for Use with Pipe Flanges" Table 7.

*Bold border □ : It may sometimes be impossible to apply adequate tightening force to joint sheets, GRASEAL gaskets and PTFE cut gaskets, so we do not recommend that they be used at nominal pressure values of 2K and 5K, as a general rule. Rubber cut gaskets and cloth reinforced gaskets are recommended.

*Double border □ : We do not recommend soft gaskets for a nominal pressure of 30K or more, as a general rule. Semi-metal gaskets are recommended.

Soft gaskets / full-face gaskets (F.F.)

■ Applicable gaskets

Joint sheet gaskets, fluororesin gaskets, GRASEAL™ gaskets, cut rubber gaskets, cloth reinforced rubber cut gaskets

■ Applicable standards

JIS B 2404-2006 "Dimensions of Gaskets for Use with Pipe Flanges," Appendix Tables 1, 2, 3 Dimensions
(Old) JIS B 2404-1999 "Dimensions of Gaskets for Use with Pipe Flanges," Table 6

■ Applicable flanges

JIS B 2220-2004 "Steel Pipe Flanges"
(Old) JIS B 2238-1996 "General Rules for Steel Pipe Flanges"
JIS B 2239-2004 "Cast Iron Pipe Flanges"
(Old) JIS B 2240-1996 "General Rules for Copper Alloy Pipe Flanges"
JIS B 2240-2006 "Copper Alloy Pipe Flanges"
(Old) JIS B 2241-1986 "Basic Dimensions of Aluminium Alloy Pipe Flanges"
JIS B 2241-2006 "Aluminium alloy pipe flanges"

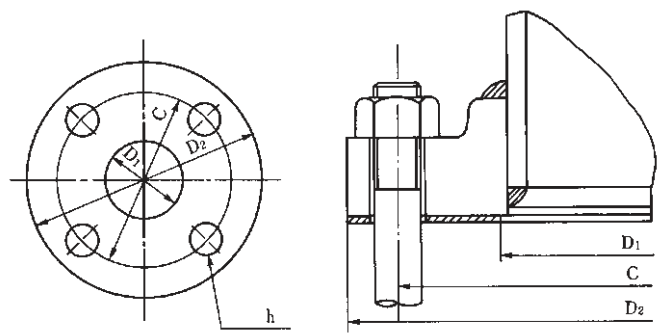

[Dimension Table 2]

Unit [mm]

Nominal flange diameter	I.D. of gasket D ₁	Nominal pressure 2K			5K			10K			16K		
		O.D. of gasket D ₂	Pitch circle diameter C	n x h	O.D. of gasket D ₂	Pitch circle diameter C	n x h	O.D. of gasket D ₂	Pitch circle diameter C	n x h	O.D. of gasket D ₂	Pitch circle diameter C	n x h
10A	18	—	—	—	75	55	4×12	90	65	4×15	90	65	4×15
15	22	—	—	—	80	60	4×12	95	70	4×15	95	70	4×15
20	28	—	—	—	85	65	4×12	100	75	4×15	100	75	4×15
25	35	—	—	—	95	75	4×12	125	90	4×19	125	90	4×19
32	43	—	—	—	115	90	4×15	135	100	4×19	135	100	4×19
40	49	—	—	—	120	95	4×15	140	105	4×19	140	105	4×19
50	61	—	—	—	130	105	4×15	155	120	4×19	155	120	8×19
65	84 (77)	—	—	—	155	130	4×15	175	140	4×19	175	140	8×19
80	90	—	—	—	180	145	4×19	185	150	8×19	200	160	8×23
90	102	—	—	—	190	155	4×19	195	160	8×19	210	170	8×23
100	115	—	—	—	200	165	8×19	210	175	8×19	225	185	8×23
125	141	—	—	—	235	200	8×19	250	210	8×23	270	225	8×25
150	167	—	—	—	265	230	8×19	280	240	8×23	305	260	12×25
175	192	—	—	—	300	260	8×23	305	265	12×23	—	—	—
200	218	—	—	—	320	280	8×23	330	290	12×23	350	305	12×25
225	244	—	—	—	345	305	12×23	350	310	12×23	—	—	—
250	270	—	—	—	385	345	12×23	400	355	12×25	430	380	12×27
300	321	—	—	—	430	390	12×23	445	400	16×25	480	430	16×27
350	359	—	—	—	480	435	12×25	490	445	16×25	540	480	16×33
400	410	—	—	—	540	495	16×25	560	510	16×27	605	540	16×33
450	460	605	555	16×23	605	555	16×25	620	565	20×27	675	605	20×33
500	513	655	605	20×23	655	605	20×25	675	620	20×27	730	660	20×33
550	564	720	665	20×25	720	665	20×27	745	680	20×33	795	720	20×39
600	615	770	715	20×25	770	715	20×27	795	730	24×33	845	770	24×39
650	667	825	770	24×25	825	770	24×27	845	780	24×33	—	—	—
700	718	875	820	24×25	875	820	24×27	905	840	24×33	—	—	—
750	770	945	880	24×27	945	880	24×33	970	900	24×33	—	—	—
800	820	995	930	24×27	995	930	24×33	1,020	950	28×33	—	—	—
850	872	1,045	980	24×27	1,045	980	24×33	1,070	1,000	28×33	—	—	—
900	923	1,095	1,030	24×27	1,095	1,030	24×33	1,120	1,050	28×33	—	—	—
1,000	1,025	1,195	1,130	28×27	1,195	1,130	28×33	1,235	1,160	28×39	—	—	—
1,100	1,130	1,305	1,240	28×27	1,305	1,240	28×33	1,345	1,270	28×39	—	—	—
1,200	1,230	1,420	1,350	32×27	1,420	1,350	32×33	1,465	1,380	32×39	—	—	—
1,350	1,385	1,575	1,505	32×27	1,575	1,505	32×33	1,630	1,540	36×45	—	—	—
1,500	1,540	1,730	1,660	36×27	1,730	1,660	36×33	1,795	1,700	40×45	—	—	—

*The values for the nominal pressure of 2K are the same as in JIS B 2404-1999 "Dimensions of Gaskets for Use with Pipe Flanges" Table 7.
 *Bold border □: It may sometimes be impossible to apply adequate tightening force to joint sheets, GRASEAL gaskets and PTFE cut gaskets, so we do not recommend that they be used at nominal pressure values of 2K and 5K, as a general rule. Rubber cut gaskets and cloth reinforced gaskets are recommended.
 *Double border □: It is difficult to seal gas, even for nominal diameters of 10K and 16K.

For JPI pipe flanges and JPI large bore flange series B

Soft gaskets / ring gaskets (F.R.) Group I

■ **Applicable gaskets**

Joint sheet gaskets, fluororesin gaskets, GRASEAL™ gaskets, rubber cut gaskets, cloth reinforced rubber cut gaskets

■ **Applicable standard**

JPI-7S-16-98 "Dimensions of Non-metal Gaskets for Pipes," Appendix Tables 1, 3, 10, 11 and 12 and Reference Appendix Table 1 Dimensions

■ **Applicable flanges**

JPI-7S-15-99 "Flanges for the Petroleum Industry"
 JPI-7S-43-01 (Series B) "Large Bore Flanges for the Petroleum Industry"
 ASME B 16.5 "Pipe Flanges and Flanged Fittings"
 ANSI B 16.5 "Steel pipe Flange"
 ASME B 16.47-1996 (series B) "Large Diameter Steel Flanges"
 API-Std 605-1980 "Large-Diameter Carbon Steel Flanges"

Slip-on welded type (socket-welded type) flange dimensions can also be used on a TAYLOR FORGE flange.

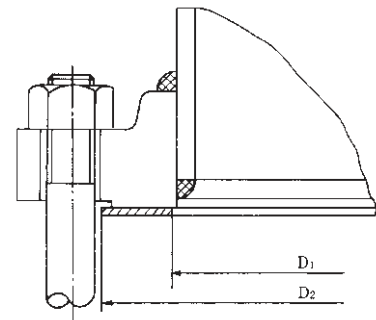

[Dimension Table 3]

Unit [mm]

Nominal flange diameter		For flat seat flange						For large bore slip-on welded type flange			
		Class 75		Class 150		Class 300		Class 175		Class 350	
A	B	I.D. D ₁	O.D. D ₂	I.D. D ₁	O.D. D ₂	I.D. D ₁	O.D. D ₂	I.D. D ₁	O.D. D ₂	I.D. D ₁	O.D. D ₂
15	1/2	—	—	22	47	22	53	—	—	—	—
20	3/4	—	—	28	56	28	66	—	—	—	—
25	1	—	—	34	66	34	72	—	—	—	—
32	1 1/4	—	—	44	75	44	82	—	—	—	—
40	1 1/2	—	—	49	85	49	94	—	—	—	—
50	2	—	—	61	104	61	110	—	—	—	—
65	2 1/2	—	—	77	123	77	129	—	—	—	—
80	3	—	—	90	135	90	148	—	—	—	—
90	3 1/2	—	—	103	161	103	164	—	—	—	—
100	4	—	—	116	173	116	180	—	—	—	—
125	5	—	—	143	196	143	215	—	—	—	—
150	6	—	—	169	221	169	249	—	—	—	—
200	8	—	—	220	277	220	306	—	—	—	—
250	10	—	—	275	338	275	360	—	—	—	—
300	12	—	—	326	408	326	420	—	—	—	—
350	14	—	—	358	449	358	484	—	—	—	—
400	16	—	—	408	512	408	538	—	—	—	—
450	18	—	—	459	547	459	595	—	—	—	—
500	20	—	—	510	604	510	651	—	—	—	—
550	22	—	—	(561)	(657)	(561)	(702)	—	—	—	—
600	24	—	—	612	715	612	772	—	—	—	—
650	26	663	705	663	722	663	768	711	737	724	749
700	28	714	756	714	773	714	822	762	787	775	800
750	30	765	807	765	824	765	883	813	845	826	857
800	32	816	857	816	878	816	937	864	895	876	908
850	34	867	908	867	932	867	991	911	949	927	959
900	36	917	970	917	984	917	1,045	962	1,000	984	1,022
950	38	968 (968)	1,021 (1,021)	968 (968)	1,041 (1,035)	968 (968)	1,096 (1,096)	1,013	1,051	1,035	1,073
1,000	40	1,019 (1,019)	1,072 (1,072)	1,019 (1,019)	1,092 (1,093)	1,019 (1,019)	1,147 (1,147)	1,064	1,102	1,080	1,124
1,050	42	1,070	1,122	1,070	1,143	1,070	1,197	1,118	1,162	1,130	1,181
1,100	44	1,121 (1,121)	1,178 (1,173)	1,121 (1,121)	1,194 (1,201)	1,121 (1,121)	1,248 (1,248)	1,168	1,213	1,191	1,241
1,150	46	1,171 (1,171)	1,229 (1,229)	1,171 (1,171)	1,253 (1,252)	1,171 (1,171)	1,315 (1,314)	1,219	1,264	1,241	1,292
1,200	48	1,222	1,280	1,222	1,303	1,222	1,365	1,270	1,314	1,292	1,343
1,250	50	1,273	1,331	1,273	1,354	1,273	1,416	1,321	1,365	—	—
1,300	52	1,324	1,384	1,324	1,405	1,324	1,467	1,372	1,422	—	—
1,350	54	1,375	1,435	1,375	1,461	1,375	1,527	1,422	1,473	—	—
1,400	56	1,425	1,493	1,425	1,511	1,425	1,591	—	—	—	—
1,450	58	1,476	1,543	1,476	1,577	1,476	1,651	—	—	—	—
1,500	60	1,527	1,594	1,527	1,625	1,527	1,702	1,575	1,626	—	—

*The dimensions in parentheses () are the flange dimensions stipulated in the old version of standard JPI-7S-43-72.
 *The values in the bold border **□** are the dimensions for series B.

For JPI pipe flanges

Soft gaskets / ring gaskets (F.R.) Group II

■ **Applicable gaskets**

The main applicable gaskets are joint sheets, and the gasket thickness is 0.8 mm or 1.5 mm

■ **Applicable standard**

JPI-7S-16-98 "Dimensions of Non-metal Gaskets for Pipes," Appendix Tables 2 and 4 Dimensions

■ **Applicable flanges**

JPI-7S-15-99 "Flanges for the Petroleum Industry"

ASME B 16.5 "Pipe Flanges and Flanged Fittings"

ANSI B 16.5 "Steel pipe Flange"

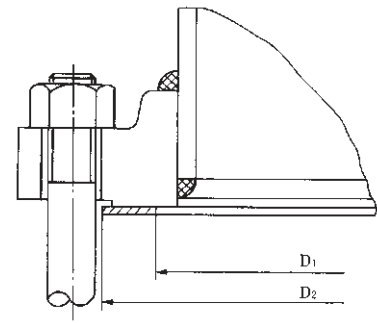

[Dimension Table 4]

Unit [mm]

Nominal flange diameter		Class 150		Class 300	
A	B	I.D. D ₁	O.D. D ₂	I.D. D ₁	O.D. D ₂
15	1/2	25	47	25	53
20	3/4	33	56	33	66
25	1	38	66	38	72
32	1 1/4	48	75	48	82
40	1 1/2	54	85	54	94
50	2	73	104	73	110
65	2 1/2	86	123	86	129
80	3	108	135	108	148
90	3 1/2	121	161	121	164
100	4	132	173	132	180
125	5	160	196	160	215
150	6	190	221	190	249
200	8	238	277	238	306
250	10	287	338	287	360
300	12	344	408	344	420
350	14	376	449	376	484
400	16	427	512	427	538
450	18	490	547	490	595
500	20	535	604	535	651
600	24	643	715	643	772

*For sealing a gas-type fluid, we recommend the Group II dimensions.

For JPI pipe flanges and JPI large bore flange series B

Soft gaskets / full-face gaskets (F.F.)

■ Applicable gaskets

Joint sheet gaskets, fluororesin gaskets, GRASEAL™ gaskets, rubber cut gaskets, cloth reinforced rubber cut gaskets

■ Applicable standard

JPI-7S-16-98 "Dimensions of Non-metal Gaskets for Pipes," Dimensions for full-face seat

■ Applicable flanges

JPI-7S-15-85 "Flanges for the Petroleum Industry"
 JPI-7S-43-84 "Large Bore flanges for the Petroleum Industry"
 ASME B 16.5 "Pipe Flanges and Flanged Fittings"
 ASME B 16.47 (series B) "Large Diameter Steel Flanges"

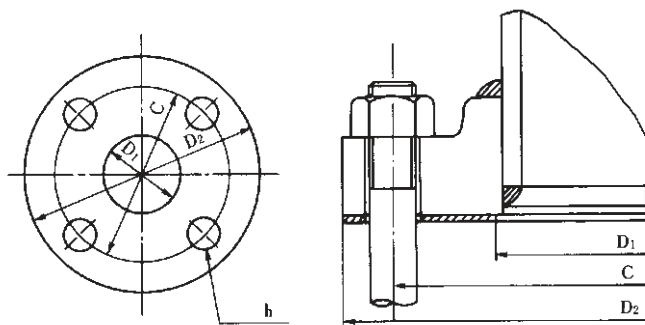

[Dimension Table 5]

Unit [mm]

Nominal flange diameter		I.D. D ₁	Class 75			Class 150			Class 300		
A	B		O.D. D ₂	Pitch circle diameter C	n x h	O.D. D ₂	Pitch circle diameter C	n x h	O.D. D ₂	Pitch circle diameter C	n x h
15	1/2	22	—	—	—	89	60.5	4 x 16	95	66.5	4 x 16
20	3/4	28	—	—	—	99	69.8	4 x 16	117	82.6	4 x 19
25	1	34	—	—	—	108	79.2	4 x 16	124	88.9	4 x 19
32	1 1/4	44	—	—	—	117	88.9	4 x 16	133	98.6	4 x 19
40	1 1/2	49	—	—	—	127	98.6	4 x 16	155	114.3	4 x 22
50	2	61	—	—	—	152	120.6	4 x 19	165	127.0	8 x 19
65	2 1/2	77	—	—	—	178	139.7	4 x 19	190	149.4	8 x 22
80	3	90	—	—	—	190	152.4	4 x 19	210	168.1	8 x 22
90	3 1/2	103	—	—	—	216	177.8	8 x 19	229	184.2	8 x 22
100	4	116	—	—	—	229	190.5	8 x 19	254	200.2	8 x 22
125	5	143	—	—	—	254	215.9	8 x 22	279	235.0	8 x 22
150	6	169	—	—	—	279	241.3	8 x 22	318	269.7	12 x 22
200	8	220	—	—	—	343	298.4	8 x 22	381	330.2	12 x 26
250	10	275	—	—	—	406	362.0	12 x 26	444	387.4	16 x 29
300	12	326	—	—	—	483	431.8	12 x 26	520	450.8	16 x 32
350	14	358	—	—	—	535	476.2	12 x 29	585	514.4	20 x 32
400	16	408	—	—	—	595	539.8	16 x 29	650	571.5	20 x 35
450	18	459	—	—	—	635	577.8	16 x 32	710	628.6	24 x 35
500	20	510	—	—	—	700	635.0	20 x 32	775	685.8	24 x 35
550	22	561	—	—	—	(750)	(692.2)	(20 x 35)	(840)	(743.0)	(24 x 42)
600	24	612	—	—	—	815	749.3	20 x 35	915	812.8	24 x 42
650	26	663	760	723.9	36 x 19	785	744.5	36 x 22	865	803.1	32 x 35
700	28	714	815	774.7	40 x 19	835	795.3	40 x 22	920	857.2	36 x 35
750	30	765	865	825.5	44 x 19	885	846.1	44 x 22	990	920.8	36 x 39
800	32	816	915	876.3	48 x 19	940	900.2	48 x 22	1,055	977.9	32 x 42
850	34	867	965	927.1	52 x 19	1,005	957.3	40 x 26	1,110	1,031.7	36 x 42
900	36	917	1,035	992.1	40 x 22	1,055	1,009.6	44 x 26	1,170	1,089.2	32 x 45
950	38	968	1,085	1,042.9	40 x 22	1,125	1,069.8	40 x 29	1,220	1,140.0	36 x 45
1,000	40	1,019	1,135	1,093.7	44 x 22	1,175	1,120.6	44 x 29	1,275	1,190.8	40 x 45
1,050	42	1,070	1,185	1,144.5	48 x 22	1,225	1,171.4	48 x 29	1,335	1,244.6	36 x 48
1,100	44	1,121	1,250	1,203.4	36 x 26	1,275	1,222.2	52 x 29	1,385	1,295.4	40 x 48
1,150	46	1,171	1,300	1,254.3	40 x 26	1,340	1,284.2	40 x 32	1,460	1,365.2	36 x 51
1,200	48	1,222	1,355	1,305.1	44 x 26	1,390	1,335.0	44 x 32	1,510	1,416.0	40 x 51
1,250	50	1,273	1,405	1,355.9	44 x 26	1,445	1,385.8	48 x 32	1,560	1,466.8	44 x 51
1,300	52	1,324	1,455	1,409.7	48 x 26	1,495	1,436.6	52 x 32	1,615	1,517.6	48 x 51
1,350	54	1,375	1,510	1,460.5	48 x 26	1,550	1,492.2	56 x 32	1,675	1,577.8	48 x 51
1,400	56	1,425	1,575	1,521.0	40 x 29	1,600	1,543.0	60 x 32	1,765	1,651.0	36 x 60
1,450	58	1,476	1,625	1,571.8	44 x 29	1,675	1,611.4	48 x 35	1,825	1,713.0	40 x 60
1,500	60	1,527	1,675	1,622.6	44 x 29	1,725	1,662.2	52 x 35	1,880	1,763.8	40 x 60

*When using a joint sheet as a full-face type, it is difficult to seal a gas-type fluid.
 *The values inside the bold border □ indicate the dimensions for series B.

For JIS pipe male and female type and tongue and groove type flanges

Soft gaskets

■ **Applicable gaskets**

Joint seal gaskets, fluororesin gaskets, GRASEAL™ gaskets

■ **Applicable standard**

JIS B 2404-2006 "Dimensions of Gaskets for Use with Pipe Flanges," Appendix Table 5 Dimensions

■ **Applicable flanges**

JIS B 2220-2004 "Steel Pipe Flanges" (Latest: 2012)
 (Old) JIS B 2238-1996 "General Rules for Steel Pipe Flanges"
 (Old) JIS B 2239-1996 "General Rules for Cast Iron Pipe Flanges"

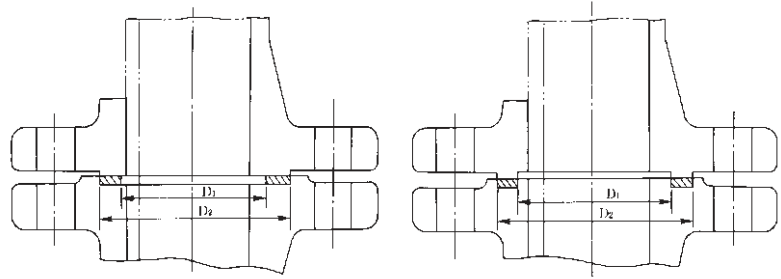

Male and female type

Tongue & groove type

[Dimension Table 6]

Unit [mm]

Nominal flange diameter	M&F type		T&G type	
	Gasket I.D. D ₁	Gasket O.D. D ₂	Gasket I.D. D ₁	Gasket O.D. D ₂
10A	18	38	28	38
15	22	42	32	42
20	28	50	38	50
25	35	60	45	60
32	43	70	55	70
40	49	75	60	75
50	61	90	70	90
65	77	110	90	110
80	90	120	100	120
90	102	130	110	130
100	115	145	125	145
125	141	175	150	175
150	167	215	190	215
200	218	260	230	260
250	270	325	295	325
300	321	375	340	375
350	359	415	380	415
400	410	475	440	475
450	460	523	483	523
500	513	575	535	575
550	564	625	585	625
600	615	675	635	675
650	667	727	682	727
700	718	777	732	777
750	770	832	787	832
800	820	882	837	882
850	872	934	889	934
900	923	987	937	987
1,000	1,025	1,092	1,042	1,092
1,100	1,130	1,192	1,142	1,192
1,200	1,230	1,292	1,237	1,292
1,300	1,335	1,392	1,337	1,392
1,350	1,385	1,442	1,387	1,442
1,400	1,435	1,492	1,437	1,492
1,500	1,540	1,592	1,537	1,592

For JPI pipe male & female flanges and tongue & groove flanges

Soft gaskets

■ Applicable gasket

The main applicable gaskets are joint sheets.

■ Applicable standard

JPI-7S-16-98 "Dimensions of Non-metal Gaskets for Pipes"

■ Applicable flanges

JPI-7S-15-99 "Flanges for the Petroleum Industry"

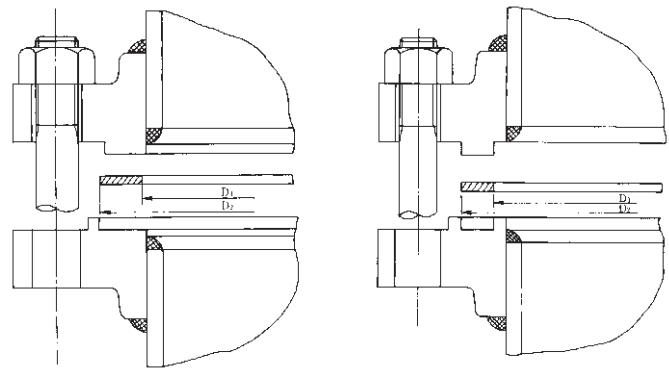

Large male & female seat type

Large tongue & groove seat type

[Dimension Table 7]

Unit [mm]

Nominal flange diameter		Large male & female seats				Large tongue & groove seat	
		Group I		Group II		Group II	
A	B	I.D. D ₁	O.D. D ₂	I.D. D ₁	O.D. D ₂	I.D. D ₁	O.D. D ₂
15	1/2	22	35	25	35	25	35
20	3/4	28	43	33	43	33	43
25	1	34	51	38	51	38	51
32	1 1/4	44	64	48	64	48	64
40	1 1/2	49	73	54	73	54	73
50	2	61	92	73	92	73	92
65	2 1/2	77	105	86	105	86	105
80	3	90	127	108	127	108	127
90	3 1/2	103	140	121	140	121	140
100	4	116	157	132	157	132	157
125	5	143	186	160	186	160	186
150	6	169	216	190	216	190	216
200	8	220	268	238	268	238	268
250	10	275	323	287	323	287	323
300	12	326	380	344	380	344	380
350	14	358	412	376	412	376	412
400	16	408	469	427	469	427	469
450	18	459	532	490	532	490	532
500	20	510	583	535	583	535	583
600	24	612	690	643	690	643	690

Soft gaskets / ring gaskets (F.R.)

■ Applicable gaskets

Joint sheet gaskets, fluororesin gaskets, GRASEAL™ gaskets, rubber cut gaskets, cloth reinforced rubber cut gaskets

■ Applicable standard

ASME B 16.21-2005 "Nonmetallic Flat Gaskets for Pipe Flanges"

■ Applicable flanges

ANSI B 16.1 "Cast Iron Pipe Flanges and Flanged Fittings"

ANSI B 16.5 "Pipe Flanges and Flanged Fittings"

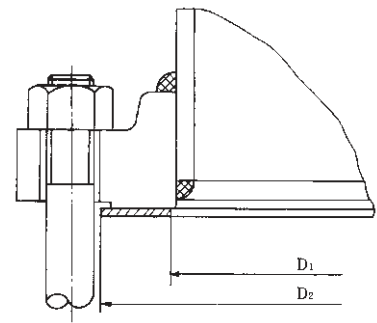

[Dimension Table 8]

Unit [mm]

Nominal flange diameter	Gasket I.D. D ₁	For ANSI B 16.1 Cast Iron flanges			For ANSI 16.5 Pipe flanges	
		Gasket O.D. D ₂			Gasket O.D. D ₂	
		Class 25	Class 125	Class 250	Class 150	Class 300
1/2B	21	—	—	—	48	54
3/4	27	—	—	—	57	67
1	33	—	67	73	67	73
1 1/4	42	—	76	83	76	83
1 1/2	49 (48)	—	86	95	86	95
2	60	—	105	111	105	111
2 1/2	73	—	124	130	124	130
3	89	—	137	149	137	149
3 1/2	102	—	162	165	162	165
4	114	175	175	181	175	181
5	141	200	197	216	197	216
6	168	225	222	251	222	251
8	219	283	279	308	279	308
10	273	346	352	362	340	362
12	324	416	410	422	410	422
14	356	457	451	486	451	486
16	406	521	514	540	514	540
18	457	559	549	597	549	597
20	508	616	606	654	606	654
24	610	730	718	775	718	775
30	762	892	883	953	—	—
36	914	1,064	1,048	1,118	—	—
42	1,067	1,232	1,219	1,289	—	—
48	1,219	1,397	1,384	1,492	—	—
54	1,372	1,568	—	—	—	—
60	1,524	1,730	—	—	—	—
72	1,829	2,067	—	—	—	—
84	2,134	2,394	—	—	—	—
96	2,438	2,724	—	—	—	—

*The use of joint sheets is not recommended for Class 25.

*The value in parentheses () is the dimension for ANSI B 16.5 Pipe flanges.

Soft gaskets / full-face gaskets (F.F.)

■ Applicable gaskets

Joint sheet gaskets, fluororesin gaskets, GRASEAL™ gaskets, rubber cut gaskets, cloth reinforced rubber cut gaskets

■ Applicable standard

ASME B 16.21-2005 "Nonmetallic Flat Gaskets for Pipe Flanges"

■ Applicable flanges

ANSI B 16.1 "Cast Iron Pipe Flanges and Flanged Fittings"
ANSI B 16.5 "Pipe Flanges and Flanged Fittings"

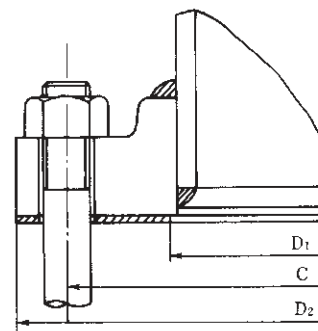
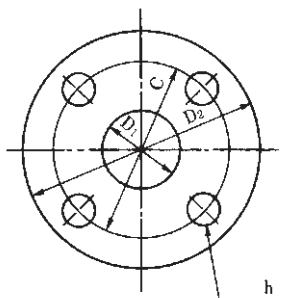

[Dimension Table 9]

Unit [mm]

Nominal flange diameter	Gasket I.D. D ₁	For ANSI B 16.1 Cast Iron flanges						For ANSI 16.5 Steel flanges		
		Class 25			Class 125			Class 150		
		O.D. D ₂	Pitch circle diameter C	n x h	O.D. D ₂	Pitch circle diameter C	n x h	O.D. D ₂	Pitch circle diameter C	n x h
1/2B	21	—	—	—	—	—	—	89	60.3	4 x 15.7
3/4	27	—	—	—	—	—	—	98	69.9	4 x 15.7
1	33	—	—	—	108	79.4	4 x 15.7	108	79.4	4 x 15.7
1 1/4	42	—	—	—	117	88.9	4 x 15.7	117	88.9	4 x 15.7
1 1/2	49	—	—	—	127	98.4	4 x 15.7	127	98.4	4 x 15.7
2	60	—	—	—	152	120.7	4 x 19.0	152	120.7	4 x 19.0
2 1/2	73	—	—	—	178	139.7	4 x 19.0	178	139.7	4 x 19.0
3	89	—	—	—	191	152.4	4 x 19.0	191	152.4	4 x 19.0
3 1/2	102	—	—	—	216	177.8	8 x 19.0	216	177.8	8 x 19.0
4	114	229	190.5	8 x 19.0	229	190.5	8 x 19.0	229	190.5	8 x 19.0
5	141	254	215.9	8 x 19.0	254	215.9	8 x 22.4	254	215.9	8 x 22.4
6	168	279	241.3	8 x 19.0	279	241.3	8 x 22.4	279	241.3	8 x 22.4
8	219	343	298.5	8 x 19.0	343	298.5	8 x 22.4	434	298.5	8 x 22.4
10	273	406	362.0	12 x 19.0	406	362.0	12 x 25.4	406	362.0	12 x 25.4
12	324	483	431.8	12 x 19.0	483	431.8	12 x 25.4	483	431.8	12 x 25.4
14	356	533	476.3	12 x 22.4	533	476.2	12 x 28.4	533	476.3	12 x 28.4
16	406	597	539.8	16 x 22.4	597	539.8	16 x 28.4	597	539.8	16 x 28.4
18	457	635	577.9	16 x 22.4	635	577.9	16 x 31.8	635	577.9	16 x 31.8
20	508	699	635.0	20 x 22.4	699	635.0	20 x 31.8	699	635.0	20 x 31.8
24	610	813	749.3	20 x 22.4	813	749.3	20 x 35.1	813	749.3	20 x 35.1
30	762	984	914.4	28 x 25.4	984	914.4	28 x 35.1	—	—	—
36	914	1,168	1,085.9	32 x 25.4	1,168	1,085.9	32 x 41.1	—	—	—
42	1,067	1,346	1,257.3	36 x 28.4	1,346	1,257.3	36 x 41.1	—	—	—
48	1,219	1,511	1,422.4	44 x 28.4	1,511	1,422.4	44 x 41.1	—	—	—
54	1,372	1,683	1,593.9	44 x 28.4	—	—	—	—	—	—
60	1,524	1,854	1,759.0	52 x 31.8	—	—	—	—	—	—
72	1,829	2,197	2,095.5	60 x 31.8	—	—	—	—	—	—
84	2,134	2,534	2,425.7	64 x 35.1	—	—	—	—	—	—
96	2,438	2,877	2,755.9	68 x 35.1	—	—	—	—	—	—

*The use of joint sheets is not recommended for Class 25 flanges.

(F.R.)

■ Applicable gaskets

Joint sheet gaskets, fluororesin gaskets, GRASEAL™ gaskets, rubber cut gaskets, cloth reinforced rubber cut gaskets

■ Applicable standard

ASME B 16.21-2005 "Nonmetallic Flat Gaskets for Pipe Flanges"

■ Applicable flanges

ASME B 16.47 (Series A) "Large Diameter Steel Flanges" (MSS-SP-44-1982 "Steel Pipe line Flanges")

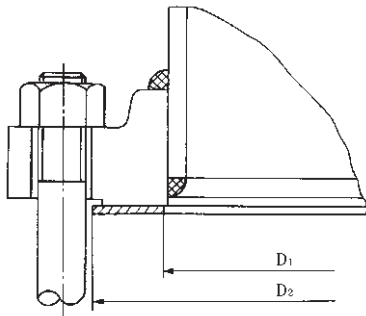

[Dimension table 10]

Unit [mm]

Nominal flange diameter	Gasket I.D. D ₁	Gasket O.D. D ₂	
		Class 150	Class 300
22 ^{*1}	559	660	705
26	660	775	835
28	711	832	899
30	762	883	953
32	813	940	1,006
34	864	991	1,057
36	914	1,048	1,118
38	965	1,111	1,054
40	1,016	1,162	1,114
42	1,067	1,219	1,165
44	1,118	1,276	1,219
46	1,168	1,327	1,273
48	1,219	1,384	1,324
50	1,270	1,435	1,378
52	1,321	1,492	1,429
54	1,372	1,549	1,492
56	1,422	1,607	1,543
58	1,473	1,664	1,594
60	1,524	1,715	1,645

*1: Because this value is not stipulated in ASME B16.47, it is only used for reference.

Union Table

■ Applicable gaskets

Mainly joint sheets

■ Reference standard²

JIS B 2301 "Screwed type malleable cast iron pipe fittings"

*2: This dimension table has been prepared by Nichias based on the above standard.

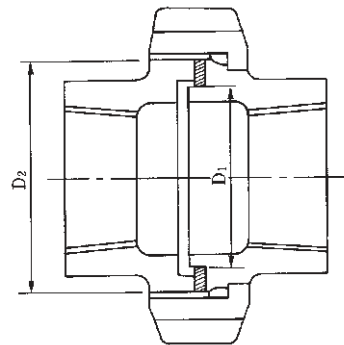

[Dimension Table 11]

Unit [mm]

Nominal union diameter	I.D. D ₁	O.D. D ₂
1/8B	13	18
1/4	17	23
3/8	21	28
1/2	25	32
3/4	31	39
1	39	48
1 1/4	47	57
1 1/2	54	64
2	66	78
2 1/2	82	96
3	96	111
3 1/2	109	126
4	122	141
5	151	170
6	178	200

*The recommended gasket thickness is 2.0 mm or 1.5 mm.

For JIS pipe flanges

Vortex™ gaskets with outer ring

■ **Applicable gaskets**

GRASEAL™ Vortex, NA Vortex, NAFLON™ Vortex, Vortex gaskets -GS, -GM and -GH

■ **Applicable standard**

JIS B 2404-2006 "Dimensions of Gaskets for Use with Pipe Flanges," Appendix Tables 6, 7, Appendix 1 Appendix Tables 2, 4 Dimensions

■ **Applicable flanges**

JIS B 2220-2004 "Steel Pipe Flanges"

(Old) JIS B 2238-1996 "General Rules for Steel Pipe Flanges"

(Old) JIS B 2239-1996 "General Rules for Cast Iron Pipe Flanges"

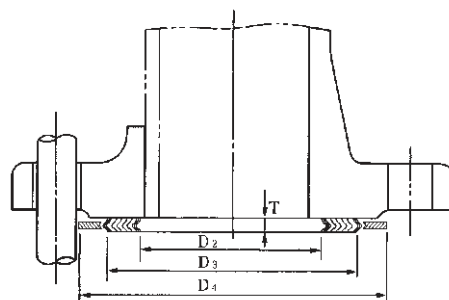

*The O.D. dimension of the body of a gasket with an outer ring is expressed as the dimension of the gasket shoulder excluding spring layers.

[Dimension Table 12]

Unit [mm]

Nominal flange diameter	Nominal pressure 10K			16, 20K			30K			40K			63K			Thickness T
	I.D. D ₂	O.D. D ₃	Outer ring outer diameter D ₄	I.D. D ₂	O.D. D ₃	Outer ring outer diameter D ₄	I.D. D ₂	O.D. D ₃	Outer ring outer diameter D ₄	I.D. D ₂	O.D. D ₃	Outer ring outer diameter D ₄	I.D. D ₂	O.D. D ₃	Outer ring outer diameter D ₄	
10A	24	37	52	24	37	52	24	37	59	21	34	59	21	34	64	4.5
15	28	41	57	28	41	57	28	41	64	24	37	64	24	37	69	
20	34	47	62	34	47	62	34	47	69	29	42	69	29	42	75	
25	40	53	74	40	53	74	40	53	79	35	48	79	35	48	80	
32	51	67	84	51	67	84	51	67	89	44	60	89	44	60	90	
40	57	73	89	57	73	89	57	73	100	51	67	100	51	67	107	
50	69	89	104	69	89	104	69	89	114	63	79	114	63	79	125	
65	87	107	124	87	107	124	78	98	140	78	98	140	78	98	152	
80	98	118	134	99	119	140	90	110	150	90	110	150	90	110	162	
90	110	130	144	114	139	150	102	127	162	102	127	162	102	127	179	
100	123	143	159	127	152	165	116	141	172	116	141	182	116	141	194	
125	148	173	190	152	177	202	140	165	207	140	165	224	140	165	235	
150	174	199	220	182	214	237	165	197	249	165	197	265	165	197	275	
175	201	226	245	—	—	—	—	—	—	—	—	—	—	—	—	
200	227	252	270	233	265	282	218	250	294	218	250	315	218	250	328	
225	252	277	290	—	—	—	—	—	—	—	—	—	—	—	—	
250	278	310	332	288	328	354	271	311	360	271	311	378	271	311	394	
300	329	361	377	339	379	404	320	360	418	320	360	434	320	360	446	
350	366	406	422	376	416	450	356	396	463	356	396	479	356	396	488	
400	417	457	484	432	482	508	403	453	524	403	453	531	403	453	545	
450	468	518	539	483	533	573	—	—	—	—	—	—	—	—	—	
500	518	568	594	533	583	628	—	—	—	—	—	—	—	—	—	
550	569	619	650	584	634	684	—	—	—	—	—	—	—	—	—	
600	620	670	700	635	685	734	—	—	—	—	—	—	—	—	—	

*The dimensions in the double border □ cannot be used on small flat seats.

*The dimensions in the bold border ■ apply to large flat seats and small flat seats. (Note, however, that these dimensions apply only to butt-welded flanges and type C slip-on welded flanges stipulated in JIS B 2220.)

*■: For a 30K type A slip-on welded flange and a type B slip-on welded flange, use the dimensions on Page 76.

*It is recommended that vortex gaskets with inner and outer rings be used on flanges that are intended for a nominal pressure of 63K.

*It is recommended that GRASEAL vortex gaskets and NAFLON vortex gaskets be fitted with inner and outer rings.

*It is not recommended that vortex gaskets be used on flanges intended for nominal pressures 2K and 5K.

*It is recommended that high-strength alloy steel bolts of SNB-7 or higher be used.

Vortex™ gaskets with inner and outer rings

■ **Applicable gaskets**

GRASEAL™ vortex, NA vortex, NAFLON™ vortex, vortex gaskets -GS, -GM and -GH

■ **Applicable standard** *1

JIS B 2404-2006 "Dimensions of Gaskets for Use with Pipe Flanges," Appendix Tables 6, 8, Appendix 1 Appendix Tables 3, 5 Dimensions

■ **Applicable flanges**

JIS B 2220-2004 "Steel Pipe Flanges"

(Old) JIS B 2238-1996 "General Rules for Steel Pipe Flanges"

(Old) JIS B 2239-1996 "General Rules for Cast Iron Pipe Flanges"

*1: The I.D. of the inner ring of a gasket for a nominal pressure of 10K has been prepared by Nichias.

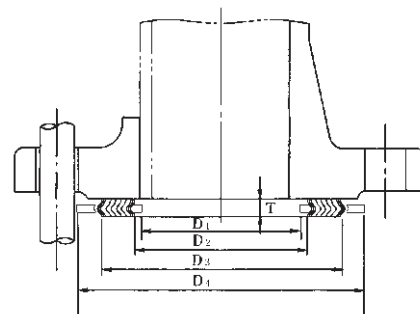

*The O.D. dimension of the body of a gasket with inner and outer rings is expressed as the dimension of the gasket shoulder excluding spring layers.

[Dimension Table 13-1]

Unit [mm]

Nominal flange diameter	Nominal pressure 10K				16, 20K				30K				40K				63K				Thickness T
	Inner ring I.D. D ₁	I.D. D ₂	O.D. D ₃	Outer ring O.D. D ₄	Inner ring I.D. D ₁	I.D. D ₂	O.D. D ₃	Outer ring O.D. D ₄	Inner ring I.D. D ₁	I.D. D ₂	O.D. D ₃	Outer ring O.D. D ₄	Inner ring I.D. D ₁	I.D. D ₂	O.D. D ₃	Outer ring O.D. D ₄	Inner ring I.D. D ₁	I.D. D ₂	O.D. D ₃	Outer ring O.D. D ₄	
10A	18	24	37	52	18	24	37	52	18	24	37	59	15	21	34	59	15	21	34	64	4.5
15	22	28	41	57	22	28	41	57	22	28	41	64	18	24	37	64	18	24	37	69	
20	28	34	47	62	28	34	47	62	28	34	47	69	23	29	42	69	23	29	42	75	
25	34	40	53	74	34	40	53	74	34	40	53	79	29	35	48	79	29	35	48	80	
32	43	51	67	84	43	51	67	84	43	51	67	89	38	44	60	89	38	44	60	90	
40	49	57	73	89	49	57	73	89	49	57	73	100	43	51	67	100	43	51	67	107	
50	61	69	89	104	61	69	89	104	61	69	89	114	55	63	79	114	55	63	79	125	
65	77	87	107	124	77	87	107	124	68	78	98	140	68	78	98	140	68	78	98	152	
80	88	98	118	134	89	99	119	140	80	90	110	150	80	90	110	150	80	90	110	162	
90	98	110	130	144	102	114	139	150	92	102	127	162	92	102	127	162	92	102	127	179	
100	111	123	143	159	115	127	152	165	104	116	141	172	104	116	141	182	104	116	141	194	
125	136	148	173	190	140	152	177	202	128	140	165	207	128	140	165	224	128	140	165	235	
150	158	174	199	220	166	182	214	237	153	165	197	249	153	165	197	265	153	165	197	275	
200	211	227	252	270	217	233	265	282	202	218	250	294	202	218	250	315	202	218	250	328	
250	258	278	310	332	268	288	328	354	251	271	311	360	251	271	311	378	251	271	311	394	
300	309	329	361	377	319	339	379	404	300	320	360	418	300	320	360	434	300	320	360	446	
350	346	366	406	422	356	376	416	450	336	356	396	463	336	356	396	479	336	356	396	488	
400	392	417	457	484	407	432	482	508	383	403	453	524	383	403	453	531	383	403	453	545	
450	443	468	518	539	458	483	533	573	—	—	—	—	—	—	—	—	—	—	—	—	
500	493	518	568	594	508	533	583	628	—	—	—	—	—	—	—	—	—	—	—	—	
550	544	569	619	650	559	584	634	684	—	—	—	—	—	—	—	—	—	—	—	—	
600	595	620	670	700	610	635	685	734	—	—	—	—	—	—	—	—	—	—	—	—	

*The dimensions in the double border □ cannot be used on small flat seats.

*The dimensions in the bold border □ apply to large flat seats and small flat seats. (Note, however, that these dimensions apply only to butt-welded flanges and type C slip-on welded flanges stipulated in JIS B 2220.)

*□: For a 30K type A slip-on welded flange and a type B slip-on welded flange, use the dimensions on Page 76.

*It is recommended that vortex gaskets with inner and outer rings be used on flanges for a nominal pressure of 63K.

*It is recommended that high-strength alloy steel bolts of SNB-7 or higher be used.

For JIS pipe large-bore flanges

Vortex™ gaskets with inner and outer rings

■ Applicable gaskets

GRASEAL™ vortex, NA vortex, NAFLON™ vortex, vortex gaskets -GS, -GM and -GH

■ Applicable flanges

JIS B 2220-2004 "Steel Pipe Flanges"

(Old) JIS B 2238-1996 "General Rules for Steel Pipe Flanges"

(Old) JIS B 2239-1996 "General Rules for Cast Iron Pipe Flanges"

*This dimension table has been prepared by Nichias based on the above standards.

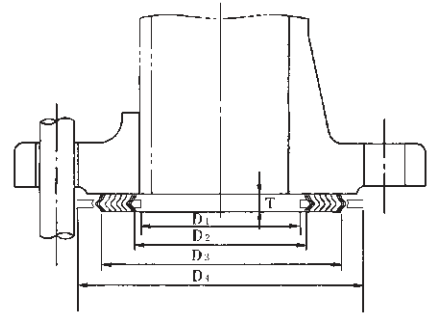

*The O.D. dimension of the body of a gasket with inner and outer rings is expressed as the dimension of a gasket shoulder excluding spring layers.

[Dimension Table 14]

Unit [mm]

Nominal flange diameter	Nominal pressure 10K				16K				20K			
	Inner ring I.D. D ₁	I.D. D ₂	O.D. D ₃	Outer ring O.D. D ₄	Inner ring I.D. D ₁	I.D. D ₂	O.D. D ₃	Outer ring O.D. D ₄	Inner ring I.D. D ₁	I.D. D ₂	O.D. D ₃	Outer ring O.D. D ₄
650A	650	675	725	750	674	699	749	784	695	720	770	805
700	701	726	776	810	716	741	791	836	740	765	815	855
750	752	777	827	870	777	802	852	896	799	824	874	918
800	803	828	878	920	831	856	906	945	865	881	931	978
850	854	879	929	970	880	905	955	995	919	944	994	1,038
900	904	929	979	1,020	934	959	1,009	1,045	971	996	1,046	1,088
1,000	1,006	1,036	1,086	1,124	1,030	1,060	1,110	1,158	—	—	—	—
1,100	1,108	1,138	1,188	1,234	1,132	1,162	1,212	1,258	—	—	—	—
1,200	1,209	1,239	1,289	1,344	1,240	1,270	1,320	1,368	—	—	—	—
1,300	—	—	—	—	1,341	1,371	1,421	1,474	—	—	—	—
1,350	1,362	1,392	1,442	1,498	1,403	1,433	1,483	1,534	—	—	—	—
1,400	—	—	—	—	1,453	1,483	1,533	1,584	—	—	—	—
1,500	1,514	1,544	1,594	1,658	1,559	1,589	1,639	1,694	—	—	—	—

*It is recommended that high-strength alloy steel bolts of SNB-7 or higher be used.

For type A slip-on welded flanges (socket-welded type)

Vortex gaskets with inner and outer rings

[Dimension Table 13-2] Unit [mm]

Nominal flange diameter	30K			
	Inner ring I.D. D ₁	I.D. D ₂	O.D. D ₃	Outer ring O.D. D ₄
10A	21.0	29.0	42.0	59.0
15	25.0	32.0	45.0	64.0
20	30.5	37.0	50.0	69.0
25	37.5	47.0	60.0	79.0
32	46.0	54.0	70.0	89.0
40	52.0	64.0	80.0	100.0
50	64.0	75.0	95.0	114.0
65	80.0	100.0	120.0	140.0
80	93.0	110.0	130.0	150.0
90	105.5	120.0	140.0	163.0
100	118.5	130.0	150.0	173.0
125	146.0	160.0	185.0	208.0
150	171.5	190.0	220.0	251.0
200	223.0	235.0	265.0	296.0
250	274.0	290.0	330.0	360.0
300	326.0	350.0	390.0	420.0
350	363.0	395.0	435.0	465.0
400	414.0	445.0	495.0	524.0

For type B slip-on welded flanges (socket-welded type)

Vortex gaskets with inner and outer rings

[Dimension Table 13-3] Unit [mm]

Nominal flange diameter	20K				30K			
	Inner ring I.D. D ₁	I.D. D ₂	O.D. D ₃	Outer ring O.D. D ₄	Inner ring I.D. D ₁	I.D. D ₂	O.D. D ₃	Outer ring O.D. D ₄
10	23	29	39	52	30	36	46	59
15	27	33	43	57	36	42	52	64
20	33	39	49	62	40	46	56	69
25	38	46	59	74	46	54	67	79
32	47	55	68	84	54	62	75	89
40	53	61	74	89	60	68	81	100
50	64	74	90	104	70	80	96	114

Slip-on welded flange (socket-welded flange)

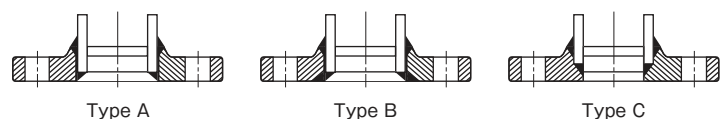

In the case of a slip-on welded type flange, the pipe is inserted into the flange, and then welded to the top part and the inner I.D. of the flange. JIS 20K and 30K flanges consist of types A, B and C in the figure above. (The figure shows hub flanges.)

For JIS pipe flanges

Basic type Vortex™ gaskets with inner ring

■ Applicable gaskets

GRASEAL™ Vortex, NA Vortex, NAFLON™ Vortex, Vortex gaskets -GS, -GM, -GH

■ Applicable standard

JIS B 2404-2006 "Dimensions of Gaskets for Use with Pipe Flanges," Table 11 to Table 13 Dimensions

■ Applicable flanges

JIS B 2220-2004 "Steel Pipe Flanges"
(Old) JIS B 2238-1996 "General Rules for Steel Pipe Flanges"

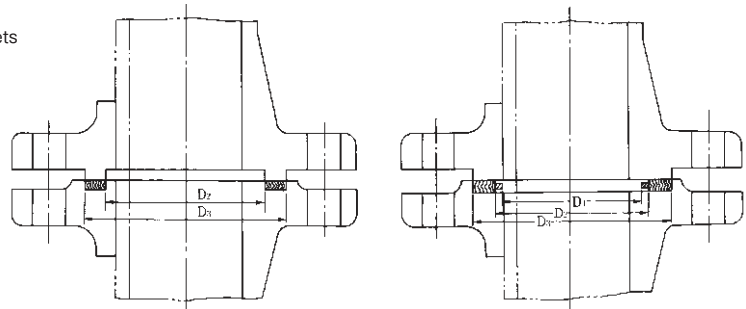

Tongue & groove type

Male & female type

[Dimension Table 5]

Unit [mm]

Nominal flange diameter	For JIS standard flanges						
	Tongue & groove type flange		Male & female type flange				
	Basic type		Basic type		With inner ring		
	I.D. D ₂	O.D. D ₃	I.D. D ₂	O.D. D ₃	Inner ring I.D. D ₁	I.D. D ₂	O.D. D ₃
10 A	28	38	25	38	19	25	38
15	32	42	29	42	23	29	42
20	38	50	37	50	31	37	50
25	45	60	44	60	38	44	60
32	55	70	54	70	46	54	70
40	60	75	59	75	51	59	75
50	70	90	70	90	62	70	90
65	90	110	90	110	80	90	110
80	100	120	100	120	90	100	120
90	110	130	110	130	100	110	130
100	125	145	125	145	113	125	145
125	150	175	150	175	138	150	175
150	190	215	187	215	171	187	215
200	230	259	231	259	215	231	259
250	296	324	288	324	268	288	324
300	341	374	338	374	318	338	374
350	381	414	376	414	356	376	414
400	441	474	434	474	409	434	474

*When you use a Vortex gasket with inner ring on a slip-on welded type flange, the inner ring I.D. protrudes from the I.D. of the flange, so be careful.
*It is recommended that high-strength alloy steel bolts of at least SNB-7 be used.

Vortex™ gaskets (15A - 600A) with (inner) outer ring

■ **Applicable gaskets**

TOMBO No.1834 (R)-GR, TOMBO No.1834 (R)-NA, TOMBO No.9090-(I) OR

■ **Applicable standard**

JPI-7S-41-2005 "Vortex Gaskets for Pipes" Appendix Tables 2, 3 and 5 Reference Appendix Table 1 Dimensions

The values in parentheses () are the values in (Old) JPI-7S-41-1998.

■ **Applicable flanges**

JPI-7S-15 "Forged Steel Flanges for the Petroleum Industry"

JPI-7S-43 "Large Bore Flanges" Series B

ANSI B 16.5-1981 "Steel Pipe Flanges"

ASME B 16.47-1996 "Large-Diameter Steel Flanges, series B"

API-Std 605-1980 "Large-Diameter Carbon Steel Flanges"

[Dimension Table 16]

Unit [mm]

Nominal flange diameter		Class 150				Class 300				Class 400			
A	B	Inner ring I.D. D ₁	Main body I.D. D ₂	Main body O.D. D ₃	Outer ring O.D. D ₄	Inner ring I.D. D ₁	Main body I.D. D ₂	Main body O.D. D ₃	Outer ring O.D. D ₄	Inner ring I.D. D ₁	Main body I.D. D ₂	Main body O.D. D ₃	Outer ring O.D. D ₄
15	1/2	14.2	19.0	31.8	47.8	14.2	19.0	31.8	54.1	14.2	19.0	31.8	54.1
20	3/4	20.6	25.4	39.6	57.2	20.6	25.4	39.6	66.8	20.6	25.4	39.6	66.8
25	1	26.9	31.8	47.8	66.8	26.9	31.8	47.8	73.2	26.9	31.8	47.8	73.2
32	1 1/4	38.1	47.8	60.5	76.2	38.1	47.8	60.5	82.6	38.1	47.8	60.5	82.6
40	1 1/2	44.4	54.1	69.8	85.9	44.4	54.1	69.8	95.2	44.4	54.1	69.8	95.2
50	2	55.6	69.8	85.9	104.9	55.6	69.8	85.9	111.3	55.6	69.8	85.9	111.3
65	2 1/2	66.5	82.6	98.6	124.0	66.5	82.6	98.6	130.3	66.5	82.6	98.6	130.3
80	3	81.0	101.6	120.6	136.7	81.0	101.6	120.6	149.4	81.0	101.6	120.6	149.4
90	3 1/2	93.7	114.3	133.3	161.9	93.7	114.3	133.3	165.1	93.7	114.3	133.3	161.9
100	4	106.4	127.0	149.4	174.8	106.4	127.0	149.4	181.1	102.6 (106.4)	120.6	149.4	177.8
125	5	131.8	155.7	177.8	196.8	131.8	155.7	177.8	215.9	128.3 (131.8)	147.6	177.8	212.9
150	6	157.2	182.6	209.6	222.2	157.2	182.6	209.6	251.0	154.9 (157.2)	174.8	209.6	247.6
200	8	215.9	233.4	263.7	279.4	215.9	233.4	263.7	308.1	205.7 (209.6)	225.6	263.7	304.8
250	10	268.2	287.3	317.5	339.9	268.2	287.3	317.5	362.0	255.3 (260.4)	274.6	317.5	358.9
300	12	317.5	339.9	374.6	409.7	317.5	339.9	374.6	422.4	307.3 (317.5)	327.2	374.6	419.1
350	14	349.2	371.6	406.4	450.8	349.2	371.6	406.4	485.9	342.9 (349.2)	362.0	406.4	482.6
400	16	400.0	422.4	463.6	514.4	400.0	422.4	463.6	539.8	389.9 (400.0)	412.8	463.6	536.7
450	18	449.3	474.7	527.0	549.4	449.3	474.7	527.0	596.9	438.1 (449.3)	469.9	527.0	593.9
500	20	500.1	525.5	577.8	606.6	500.1	525.5	577.8	654.0	488.9 (500.1)	520.7	577.8	647.7
550	22	552.4	577.8	635.0	660.4	552.4	577.8	635.0	704.8	552.4	577.8	635.0	701.8
600	24	603.2	628.6	685.8	717.6	603.2	628.6	685.8	774.7	590.5 (603.2)	628.6	685.8	768.4

*When using this type of gasket on a flange that has a nominal pressure of at least Class 900, use a butt-welded flange.

* Use high-strength alloy steel bolts of SNB-7 or higher.

* When using this type of gasket on a slip-on welded flange, the inner ring I.D. may sometimes protrude from the I.D. of the flange, so be careful. The use of a butt-welded flange is recommended.

*The values inside the bold border **□** cannot be used for a slip-on welded flange. Use them for a butt-welded flange or a socket-welded flange. (For the dimensions in the case where a slip-on welded flange is used, refer to Dimension Table 17 at bottom right.)

* **□**: When using this type of gasket on a flange that has a nominal pressure of at least Class 900, it is recommended that you use a gasket with inner and outer rings.

For slip-on welded flanges (socket-welded flange)

Dimensions (inside the bold border of Table 16) when this type of gasket is to be used for a slip-on welded flange

■ **Flange classification**

Slip-on welded flange (socket-welded type)

Socket-welded flange

Butt-welded flange

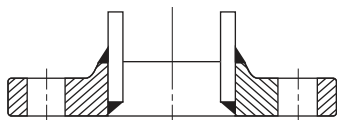

A type of flange into which the pipe is inserted into the flange and welded to the top part and the inner I.D. of the flange

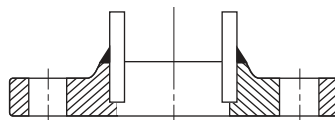

In the case of this flange, the pipe is placed on the step at I.D. of the flange and welded only to the top part of the flange. Because the I.D. side is not welded, there is a risk of the flange face becoming damaged.

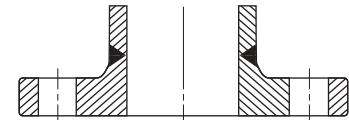

A type of flange to which the pipe is directly butt-welded

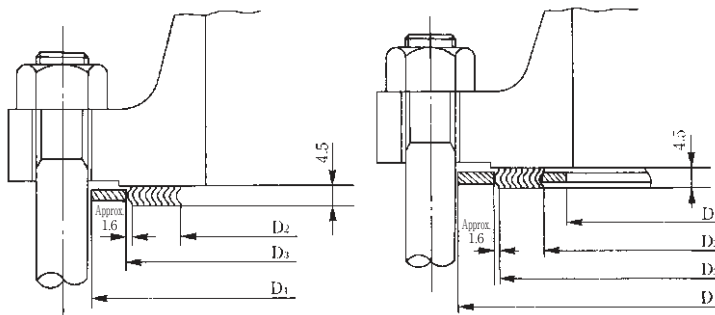

*The O.D. of the main body is expressed as the dimension of the convex part excluding spring layers.

Unit [mm]

Nominal flange diameter		Class 600				Class 900				Class 1500				Class 2500			
A	B	Inner ring I.D. D ₁	Main body I.D. D ₂	Main body O.D. D ₃	Outer ring O.D. D ₄	Inner ring I.D. D ₁	Main body I.D. D ₂	Main body O.D. D ₃	Outer ring O.D. D ₄	Inner ring I.D. D ₁	Main body I.D. D ₂	Main body O.D. D ₃	Outer ring O.D. D ₄	Inner ring I.D. D ₁	Main body I.D. D ₂	Main body O.D. D ₃	Outer ring O.D. D ₄
15	1/2	14.2	19.0	31.8	54.1	14.2	19.0	31.8	63.5	14.2	19.0	31.8	63.5	14.2	19.0	31.8	69.8
20	3/4	20.6	25.4	39.6	66.8	20.6	25.4	39.6	69.8	20.6	25.4	39.6	69.8	20.6	25.4	39.6	76.2
25	1	26.9	31.8	47.8	73.2	26.9	31.8	47.8	79.5	26.9	31.8	47.8	79.5	26.9	31.8	47.8	85.9
32	1 1/4	38.1	47.8	60.5	82.6	33.3	39.6	60.5	88.9	33.3	39.6	60.5	88.9	33.3	39.6	60.5	104.9
40	1 1/2	44.4	54.1	69.8	95.2	41.4	47.8	69.8	98.6	41.4	47.8	69.8	98.6	41.4	47.8	69.8	117.6
50	2	55.6	69.8	85.9	111.3	52.3	58.7	85.9	143.0	52.3	58.7	85.9	143.0	52.3	58.7	85.9	146.0
65	2 1/2	66.5	82.6	98.6	130.3	63.5	69.8	98.6	165.1	63.5	69.8	98.6	165.1	63.5	69.8	98.6	168.4
80	3	78.7 (81.0)	101.6	120.6	149.4	78.7 (81.0)	95.2	120.6	168.4	78.7 (81.0)	92.2	120.6	174.8	78.7 (81.0)	92.2	120.6	196.8
90	3 1/2	93.7	114.3	133.3	161.9	—	—	—	—	—	—	—	—	—	—	—	—
100	4	102.9 (106.4)	120.6	149.4	193.8	102.9 (106.4)	120.6	149.4	206.5	97.9 (106.4)	117.6	149.4	209.6	97.9 (106.4)	117.6	149.4	235.0
125	5	129.3 (131.8)	147.6	177.8	241.3	129.3 (131.8)	147.6	177.8	247.6	124.5 (131.8)	143.0	177.8	254.0	124.5 (131.8)	143.0	177.8	279.4
150	6	154.9 (157.2)	174.8	209.6	266.7	154.9 (157.2)	174.8	209.6	289.1	147.3 (157.2)	171.4	209.6	282.7	147.3 (157.2)	171.4	209.6	317.5
200	8	205.7 (209.6)	225.6	263.7	320.8	196.8 (209.6)	222.2	257.3	358.9	196.8 (206.2)	215.9	257.3	352.6	196.8 (200.2)	215.9	257.3	387.4
250	10	255.3 (260.4)	274.6	317.5	400.0	246.1 (260.4)	276.4	311.2	435.1	246.1 (257.8)	266.7	311.2	435.1	246.1 (247.6)	270.0	311.2	476.2
300	12	307.3 (317.5)	327.2	374.6	457.2	292.1 (314.5)	323.8	368.3	498.6	292.1 (314.5)	323.8	368.3	520.7	292.1	317.5	368.3	549.4
350	14	342.9 (349.2)	362.0	406.4	492.3	320.8 (342.9)	355.6	400.0	520.7	320.8 (339.9)	362.0	400.0	577.8	—	—	—	—
400	16	389.8 (390.8)	412.8	463.6	565.2	374.9 (393.9)	412.8	457.2	574.8	369.3 (389.3)	406.4	457.2	641.4	—	—	—	—
450	18	438.1 (438.3)	469.9	527.0	612.9	425.4 (442.5)	463.6	520.7	638.3	425.4 (438.2)	463.6	520.7	704.8	—	—	—	—
500	20	488.9 (500.1)	520.7	577.8	682.8	482.3 (495.3)	520.7	571.5	698.5	478.2 (489.6)	514.4	571.5	755.6	—	—	—	—
550	22	552.4	577.8	635.0	733.6	—	—	—	—	—	—	—	—	—	—	—	—
600	24	593.5 (603.2)	628.6	685.8	790.7	593.5 (603.2)	628.6	679.4	838.2	577.8	616.0	679.4	901.7	—	—	—	—

[Dimension Table 17]

Unit [mm]

Nominal flange diameter		Class 150				Class 300·400·600				Class 900				Class 1500			
A	B	Inner ring I.D. D ₁	Main body I.D. D ₂	Main body O.D. D ₃	Outer ring O.D. D ₄	Inner ring I.D. D ₁	Main body I.D. D ₂	Main body O.D. D ₃	Outer ring O.D. D ₄	Inner ring I.D. D ₁	Main body I.D. D ₂	Main body O.D. D ₃	Outer ring O.D. D ₄	Inner ring I.D. D ₁	Main body I.D. D ₂	Main body O.D. D ₃	Outer ring O.D. D ₄
15	1/2	18.2	24.2	34.9	49.1	18.2	24.2	34.9	55.5	18.2	24.2	34.9	65.0	18.2	24.2	34.9	65.0
20	3/4	23.0	29.7	42.9	58.7	23.0	29.7	42.9	68.1	23.0	29.7	42.9	71.4	23.0	29.7	42.9	71.4
25	1	30.0	36.5	50.8	68.2	30.0	36.5	50.8	74.5	30.0	36.5	50.8	80.9	30.0	36.5	50.8	80.9
(32)	(1/4)	—	—	—	—	—	—	—	—	33.3	46.0	63.5	90.4	33.3	46.0	63.5	90.4
40	1 1/2	—	—	—	—	—	—	—	—	41.4	50.8	73.2	100.1	41.4	50.8	73.2	100.1
50	2	—	—	—	—	—	—	—	—	52.3	63.5	91.9	144.5	52.3	63.5	91.9	144.5
65	2 1/2	—	—	—	—	—	—	—	—	63.5	79.5	104.6	166.6	63.5	79.5	104.6	166.6
350	14	—	—	—	—	—	—	—	—	342.9	363.0	400.0	520.7	—	—	—	—

*This dimension table has been prepared by Nichias, based on JPI-7S-15-1999 "Flanges for the Petroleum Industry."
 *It is recommended that all bolts be made of alloy steel (high strength bolts of SNB-7 or higher).
 *The O.D. dimension of the body of a gasket is expressed as the dimension of the gasket shoulder excluding spring layers.
 *The O.D. of the body of a gasket with an outer ring and an inner ring is expressed as the dimension of the convex part excluding spring layers.

For JPI pipe large bore flange series B

Vortex™ gaskets (65A - 1500A) with (inner) outer ring

■ Applicable gaskets

GRASEAL™ vortex, NA vortex, NAFLON™ vortex, vortex gaskets
-GS, -GM, -GH

■ Applicable standard

JPI-7S-41-2005 "Vortex Gaskets for Pipes" Appendix Tables 2,
3 and 5 Reference Appendix Table 1 Dimensions
Values in parentheses () in the Dimension Table are in (Old) JPI-
7S-41-1990 Appendix Table 3.

■ Applicable flanges

JPI-7S-15 "Forged Steel Flanges for the Petroleum Industry"
JPI-7S-43 "Large Bore Flanges" Series B
ANSI B 16.5-1981 "Steel Pipe Flanges"
ASME B 16.47-1996 "Large-Diameter Steel Flanges, series B"
API-Std 605-1980 "Large-Diameter Carbon Steel Flanges"

[Dimension Table 18-1]

Unit [mm]

Normal flange diameter		Class 150				Class 300			
A	B	Inner ring I.D. D ₁	Main body I.D. D ₂	Main body O.D. D ₃	Outer ring O.D. D ₄	Inner ring I.D. D ₁	Main body I.D. D ₂	Main body O.D. D ₃	Outer ring O.D. D ₄
650	26	654.0	673.1	698.5	725.4	654.0	673.1	711.2	771.7
700	28	704.8	723.9	749.3	776.2	704.8	723.9	762.0	825.5
750	30	755.6	774.7	800.1	827.0	755.6	774.7	812.8	886.0
800	32	806.4	825.5	850.9	881.1	806.4	825.5	863.6	939.8
850	34	857.2	876.3	908.0	935.0	857.2	876.3	914.4	993.9
900	36	908.0	927.1	958.8	987.6	908.0	927.1	965.2	1,047.8
950	38	958.8	974.6	1,009.6	1,044.7	971.6	1,009.6	1,047.8	1,098.6
1,000	40	1,009.6	1,022.4	1,063.8	1,095.5	1,022.4	1,060.4	1,098.6	1,149.4
1,050	42	1,060.4	1,079.5	1,114.6	1,146.3	1,085.8	1,111.2	1,149.4	1,200.2
1,100	44	1,111.2	1,124.0	1,165.4	1,197.1	1,124.0	1,162.0	1,200.2	1,251.0
1,150	46	1,162.0	1,181.1	1,224.0	1,255.8	1,178.1	1,216.2	1,254.3	1,317.8
1,200	48	1,212.8	1,231.9	1,270.0	1,306.6	1,231.9	1,263.6	1,311.4	1,368.6
1,250	50	1,263.6	1,282.7	1,325.6	1,357.4	1,267.0	1,317.8	1,355.9	1,419.4
1,300	52	1,314.4	1,333.5	1,376.4	1,408.2	1,317.8	1,368.6	1,406.7	1,470.2
1,350	54	1,365.2	1,384.3	1,422.4	1,463.8	1,365.2	1,403.4	1,454.2	1,530.4
1,400	56	1,422.4	1,444.8	1,477.8	1,514.6	1,428.8	1,479.6	1,524.0	1,593.8
1,450	58	1,478.0	1,500.4	1,528.8	1,579.6	1,484.4	1,535.2	1,573.3	1,655.8
1,500	60	1,535.2	1,557.3	1,586.0	1,630.4	1,557.3	1,589.0	1,630.4	1,706.6

[Dimension Table 18-2]

Unit [mm]

Normal flange diameter		Class400				Class600				Class 900			
A	B	Inner ring I.D. D ₁	Main body I.D. D ₂	Main body O.D. D ₃	Outer ring O.D. D ₄	Inner ring I.D. D ₁	Main body I.D. D ₂	Main body O.D. D ₃	Outer ring O.D. D ₄	Inner ring I.D. D ₁	Main body I.D. D ₂	Main body O.D. D ₃	Outer ring O.D. D ₄
650	26	654.0	666.8	698.5	746.3	644.7	663.7	714.5	765.3	673.1	692.2	749.3	838.2
700	28	701.8	714.5	749.3	800.1	692.2	704.8	755.6	819.2	723.9	743.0	800.1	901.7
750	30	752.6	765.3	806.4	857.2	752.6	778.0	828.8	879.6	787.4	806.4	857.2	958.8
800	32	800.1	812.8	860.6	911.4	793.8	831.8	882.6	933.4	838.2	863.6	914.4	1,016.0
850	34	850.9	866.9	911.4	962.2	850.9	889.0	939.8	997.0	895.4	920.8	971.6	1,073.2
900	36	898.7	917.7	965.2	1,022.4	901.7	939.8	990.6	1,047.8	927.1	946.2	997.0	1,124.0
950	38	(952.5)	(971.6)	(1,022.4)	(1,073.2)	(952.5)	(990.6)	(1,041.4)	(1,104.9)	1009.6	1,035.0	1,085.8	1,200.2
1,000	40	(1,000.2)	(1,025.6)	(1,076.4)	(1,127.2)	(1,009.6)	(1,047.8)	(1,098.6)	(1,155.7)	1,060.4	1,098.6	1,149.4	1,251.0
1,050	42	(1,051.0)	(1,076.4)	(1,127.2)	(1,178.0)	(1,066.8)	(1,104.9)	(1,155.7)	(1,219.2)	1,111.2	1,149.4	1,200.2	1,301.8
1,100	44	(1,104.9)	(1,130.3)	(1,181.1)	(1,231.9)	(1,111.2)	(1,162.0)	(1,212.8)	(1,270.0)	1,155.7	1,206.5	1,257.3	1,368.6
1,150	46	(1,168.4)	(1,193.8)	(1,244.6)	(1,289.0)	(1,162.0)	(1,212.8)	(1,263.6)	(1,327.2)	1,219.2	1,270.0	1,320.8	1,435.1
1,200	48	(1,206.5)	(1,244.6)	(1,295.4)	(1,346.2)	(1,219.2)	(1,270.0)	(1,320.8)	(1,390.6)	1,270.0	1,320.8	1,371.6	1,485.9
1,250	50	(1,257.3)	(1,295.4)	(1,346.2)	(1,403.4)	(1,270.0)	(1,320.8)	(1,371.6)	(1,447.8)	—	—	—	—
1,300	52	(1,308.1)	(1,346.2)	(1,397.0)	(1,454.2)	(1,320.8)	(1,371.6)	(1,422.4)	(1,498.6)	—	—	—	—
1,350	54	(1,352.6)	(1,403.4)	(1,454.2)	(1,517.6)	(1,378.0)	(1,428.8)	(1,479.6)	(1,555.8)	—	—	—	—
1,400	56	(1,403.4)	(1,454.2)	(1,505.0)	(1,568.4)	(1,428.8)	(1,479.6)	(1,530.4)	(1,612.9)	—	—	—	—
1,450	58	(1,454.2)	(1,505.0)	(1,555.8)	(1,619.2)	(1,473.2)	(1,536.7)	(1,587.5)	(1,663.7)	—	—	—	—
1,500	60	(1,517.6)	(1,568.4)	(1,619.2)	(1,682.8)	(1,530.4)	(1,593.8)	(1,644.6)	(1,733.6)	—	—	—	—

*Use high-strength alloy steel bolts of SNB-7 or higher.

*When using this type of gasket on a slip-on welded flange, the inner ring I.D. may sometimes protrude from the I.D. of the flange, so be careful. The use of a butt-welded flange is recommended.

*: When using this type of gasket on a flange that has a nominal pressure of at least Class 900, it is recommended that you use a gasket with inner and outer rings.

*In the case of a large bore flange that has a nominal diameter of at least 26B (650A), it is recommended that a gasket with inner and outer rings be used.

Basic type vortex™ gaskets with inner ring

■ Applicable gaskets

GRASEAL™ vortex, NA vortex, NAFLON™ vortex, vortex gaskets -GS, -GM, -GH

■ Applicable standard

JPI-7S-41-2005 "Vortex Gaskets for Pipes" Appendix Table 6 Dimensions
 Values in parentheses [] in the Dimension Table are in (Old) JPI-7S-41-1998.

■ Applicable flanges

JPI-7S-15 "Forged Steel Flanges for the Petroleum Industry" ANSI B 16.5 "Pipe Flanges and Flanged Fittings"

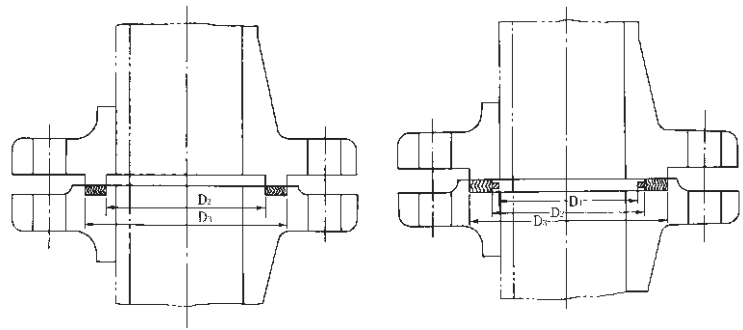

Large tongue and groove seat

Large male and female seat

[Dimension Table 19]

Unit [mm]

Nominal flange diameter		Inner ring I.D. D ₁					I.D. D ₂	O.D. D ₃
A	B	Class 300	Class 400 Class 600	Class 900	Class 1500	Class 2500		
15	1/2	14.2	14.2	14.2	14.2	14.2	25.1	35.4
20	3/4	20.6	20.6	20.6	20.6	20.6	33.0	43.2
25	1	26.9	26.9	26.9	26.9	26.9	37.8	51.1
32	1 1/4	38.1	38.1	33.3	33.3	33.3	47.2	63.8
40	1 1/2	44.4	44.4	41.4	41.4	41.4	53.5	73.5
50	2	55.6	55.6	52.3	52.3	52.3	72.6	92.5
65	2 1/2	66.5	66.5	63.5	63.5	63.5	85.3	105.2
80	3	81.0	81.0	78.7 (81.0)	78.7 (81.0)	78.7 (81.0)	107.6	127.3
90	3 1/2	93.7	93.7	—	—	—	120.3	140.0
100	4	106.4	102.6 (106.4)	102.6 (106.4)	97.8 (106.4)	97.8 (106.4)	131.2	157.6
125	5	131.8	128.3 (131.8)	128.3 (131.8)	124.5 (131.8)	124.5 (131.8)	160.0	186.3
150	6	157.2	154.9 (157.2)	154.9 (157.2)	147.3 (157.2)	147.3 (157.2)	190.2	216.3
200	8	215.9	205.7 (209.6)	196.8 (209.6)	196.8 (206.2)	196.8 (200.2)	237.7	270.0
250	10	268.2	255.3 (260.4)	246.1 (260.4)	246.1 (257.8)	246.1 (247.6)	285.7	323.9
300	12	317.5	307.3 (317.5)	292.1 (314.5)	292.1 (314.5)	291.1 (292.1)	342.9	381.0
350	14	349.2	342.9 (349.2)	320.8 (342.9)	320.8 (339.8)	—	374.6	412.8
400	16	400.0	389.9 (400.0)	374.6 (393.7)	368.3 (387.4)	—	425.4	469.9
450	18	449.3	438.1 (449.3)	425.4 (444.5)	425.4 (438.2)	—	488.9	533.4
500	20	500.1	488.9 (500.1)	482.6 (495.3)	476.2 (489.0)	—	533.4	584.2
600	24	603.2	590.5 (603.2)	590.5 (603.2)	577.8	—	641.8	691.7

*It is recommended that the depth of the groove in the seat be at least 5.5 mm, taking into consideration the allowable thickness of the gasket.

*Neither a large male and female seat nor a large tongue and groove seat exists in Class 150.

*■ : When using a large male and female seat of Class 900 or higher, we recommend to use a gasket that has an inner ring, regardless of the kind of filler material used.

*It is recommended that high-strength alloy steel bolts of SNB-7 or higher be used.

Vortex™ gasket outer ring in the case where metric thread bolts are used

■ Applicable gaskets

GRASEAL™ vortex, NA vortex, NAFLON™ vortex, vortex gaskets -GS, -GM, -GH

■ Applicable standard

JPI-7S-41-2005 "Vortex Gaskets for Pipes" Appendix, Appendix Tables 1, 2, Appendix, Reference Appendix Table 1 Dimensions

[Dimension Table 20]

Unit [mm]

Nominal diameter		Class 150		Class 300		Class 400		Class 600	
A	B	Nominal size of metric screw thread bolts	Outer ring O.D. D ₄	Nominal size of metric screw thread bolts	Outer ring O.D. D ₄	Nominal size of metric screw thread bolts	Outer ring O.D. D ₄	Nominal size of metric screw thread bolts	Outer ring O.D. D ₄
15	1/2	M14	45.5	M14	51.5	M14	51.5	M14	51.5
20	3/4	M14	54.8	M16	65.6	M16	65.6	M16	65.6
25	1	M14	64.2	M16	71.9	M16	71.9	M16	71.9
32	1 1/4	M14	73.9	M16	81.6	M16	81.6	M16	81.6
40	1 1/2	M14	83.6	M20	93.3	M20	93.3	M20	93.3
50	2	M16	103.6	M16	110.0	M16	110.0	M16	110.0
65	2 1/2	M16	122.7	M20	128.4	M20	128.4	M20	128.4
80	3	M16	135.4	M20	147.1	M20	147.1	M20	147.1
90	3 1/2	M16	160.8	M20	163.2	M24	159.2	M24	159.2
100	4	M16	173.5	M20	179.2	M24	175.2	M24	190.9
125	5	M20	194.9	M20	214.0	M24	210.0	M27	238.7
150	6	M20	220.3	M20	248.7	M24	244.7	M27	264.1
200	8	M20	277.4	M24	305.2	M27	302.2	M30 × 3	318.2
250	10	M24	337.0	M27	359.4	M30 × 3	356.4	M33 × 3	397.8
300	12	M24	406.8	M30 × 3	419.8	M33 × 3	416.8	M33 × 3	455.0
350	14	M27	448.2	M30 × 3	483.4	M33 × 3	480.4	M36 × 3	490.0
400	16	M27	511.8	M33 × 3	537.5	M36 × 3	534.5	M39 × 3	563.2
450	18	M30 × 3	546.8	M33 × 3	594.6	M36 × 3	591.6	M42 × 3	611.0
500	20	M30 × 3	604.0	M33 × 3	651.8	M39 × 3	645.8	M42 × 3	680.9
550	22	M33 × 3	659.2	M39 × 3	704.0	M42 × 3	701.0	M45 × 3	732.7
600	24	M30 × 3	715.3	M39 × 3	772.8	M45 × 3	766.8	M48 × 3	789.2

*It is recommended that all bolts be made of alloy steel (high strength bolts of SNB-7 or higher).

*The values inside the bold border **□** cannot be used for a slip-on welded flange.

*The inner ring I.D. of the gasket may sometimes protrude from the I.D. of the flange, so be careful.

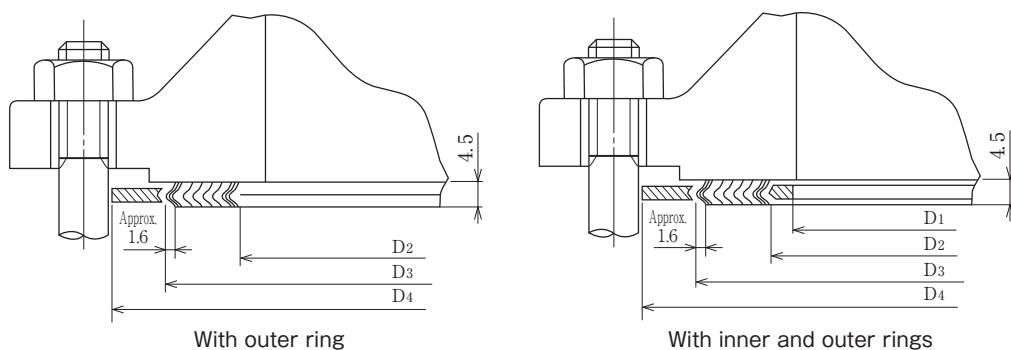

With outer ring

With inner and outer rings

*The O.D. dimension of the body of a gasket with an outer ring is expressed as the dimension of the gasket shoulder excluding spring layers.

Unit [mm]

Nominal diameter		Class 900		Class 1500		Class 2500	
A	B	Nominal size of metric screw thread bolts	Outer ring O.D. D ₄	Nominal size of metric screw thread bolts	Outer ring O.D. D ₄	Nominal size of metric screw thread bolts	Outer ring O.D. D ₄
15	½	M20	61.6	M20	61.6	M20	67.9
20	¾	M20	67.9	M20	67.9	M20	74.2
25	1	M24	76.6	M24	76.6	M24	83.0
32	1 ¼	M24	86.3	M24	86.3	M27	102.0
40	1 ½	M27	96.0	M27	96.0	M30 × 3	115.0
50	2	M24	140.1	M24	140.1	M27	143.4
65	2 ½	M27	162.5	M27	162.5	M30 × 3	165.8
80	3	M24	165.5	M30 × 3	172.2	M33 × 3	194.6
90	3 ½	—	—	—	—	—	—
100	4	M30 × 3	204.0	M33 × 3	207.3	M39 × 3	233.0
125	5	M33 × 3	245.4	M39 × 3	252.1	M45 × 3	277.8
150	6	M30 × 3	286.5	M36 × 3	280.5	M52 × 3	315.3
200	8	M36 × 3	356.7	M42 × 3	350.7	M52 × 3	385.2
250	10	M36 × 3	432.9	M48 × 3	433.6	M64 × 3	474.8
300	12	M36 × 3	496.4	M52 × 3	518.5	M70 × 3	548.3
350	14	M39 × 3	518.8	M56 × 3	578.0	—	—
400	16	M42 × 3	573.0	M64 × 3	639.8	—	—
450	18	M48 × 3	636.8	M70 × 3	703.7	—	—
500	20	M52 × 3	696.3	M76 × 3	754.8	—	—
600	24	M64 × 3	836.7	M90 × 3	899.6	—	—

Vortex™ gaskets with (inner) outer ring

■ Applicable gaskets

GRASEAL™ vortex, NA vortex, NAFLON™ vortex, vortex gaskets -GS, -GM, -GH

■ Applicable standard

ASME B16.5 "METALLIC GASKETS FOR PIPE FLANGES" TABLE 9, 12 Dimensions

■ Applicable flange

ASME B16.5 "Pipe Flanges and Flanged Fittings"

[Dimension table 21]

Unit [mm]

Nominal diameter	Class 150				Class 300				Class 400				Class 600			
	Inner ring I.D. D ₁	Main body I.D. D ₂ O.D. D ₃		Outer ring O.D. D ₄	Inner ring I.D. D ₁	Main body I.D. D ₂ O.D. D ₃		Outer ring O.D. D ₄	Inner ring I.D. D ₁	Main body I.D. D ₂ O.D. D ₃		Outer ring O.D. D ₄	Inner ring I.D. D ₁	Main body I.D. D ₂ O.D. D ₃		Outer ring O.D. D ₄
1/2	14.2	19.1	31.8	47.8	14.2	19.1	31.8	54.1	Use a Class 600 flange gasket.				14.2	19.1	31.8	54.1
3/4	20.6	25.4	39.6	57.2	20.6	25.4	39.6	66.8					20.6	25.4	39.6	66.8
1	26.9	31.8	47.8	66.8	26.9	31.8	47.8	73.2					26.9	31.8	47.8	73.2
1 1/4	38.1	47.8	60.5	76.2	38.1	47.8	60.5	82.6					38.1	47.8	60.5	82.6
1 1/2	44.5	54.1	69.9	85.9	44.5	54.1	69.9	95.3					44.5	54.1	69.9	95.3
2	55.6	69.9	85.9	104.9	55.6	69.9	85.9	111.3					55.6	69.9	85.9	111.3
2 1/2	66.5	82.6	98.6	124.0	66.5	82.6	98.6	130.3					66.5	82.6	98.6	130.3
3	81.0	101.6	120.7	136.7	81.0	101.6	120.7	149.4					81.0	101.6	120.7	149.4
4	106.4	127.0	149.4	174.8	106.4	127.0	149.4	181.1	102.6	120.7	149.4	177.8	102.6	120.7	149.4	193.8
5	131.8	155.7	177.8	196.9	131.8	155.7	177.8	215.9	128.3	147.6	177.8	212.9	128.3	147.6	177.8	241.3
6	157.2	182.6	209.6	222.3	157.2	182.6	209.6	251.0	154.9	174.8	209.6	247.7	154.9	174.8	209.6	266.7
8	215.9	233.4	263.7	279.4	215.9	233.4	263.7	308.1	205.7	225.6	263.7	304.8	205.7	225.6	263.7	320.8
10	268.2	287.3	317.5	339.9	268.2	287.3	317.5	362.0	255.3	274.6	317.5	358.9	255.3	274.6	317.5	400.1
12	317.5	339.9	374.7	409.7	317.5	339.9	374.7	422.4	307.3	327.2	374.7	419.1	307.3	327.2	374.7	457.2
14	349.3	371.6	406.4	450.9	349.3	371.6	406.4	485.9	342.9	362.0	406.4	482.6	342.9	362.0	406.4	492.3
16	400.1	422.4	463.6	514.4	400.1	422.4	463.6	539.8	389.9	412.8	463.6	536.7	389.9	412.8	463.6	565.2
18	449.3	474.7	527.1	549.4	449.3	474.7	527.1	596.9	438.2	469.9	527.1	593.9	438.2	469.9	527.1	612.9
20	500.1	525.5	577.9	606.6	500.1	525.5	577.9	654.1	489.0	520.7	577.9	647.7	489.0	520.7	577.9	682.8
24	603.3	628.7	685.8	717.6	603.3	628.7	685.8	774.7	590.6	628.7	685.8	768.4	590.6	628.7	685.8	790.7

*It is recommended that all bolts be made of alloy steel (high strength bolts of SNB-7 or higher).

*ASME B16.20-1998 stipulates a smaller inner ring I.D. for some sizes, so be careful.

*Class 400 nominal diameters of 1/2 - 3B gaskets do not exist, so a Class 600 flange gasket shall be used instead.

*Class 900 nominal diameter 1/2 - 2 1/2B gaskets do not exist, so a Class 1500 flange gasket shall be used instead.

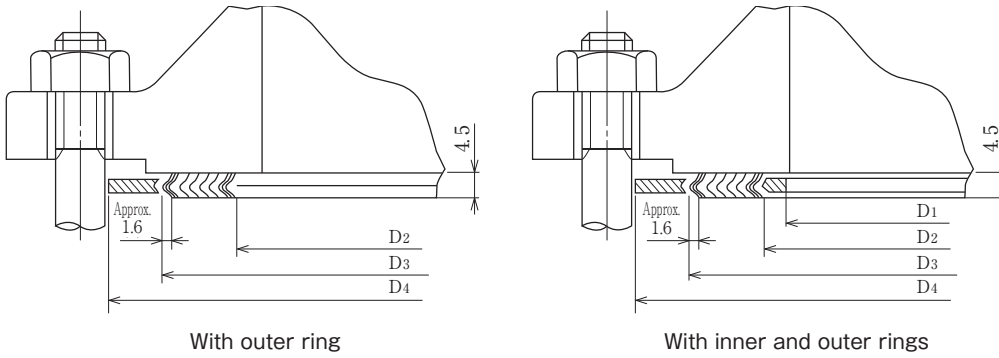

*The O.D. of the body of a gasket with an outer ring and an inner ring is expressed as the dimension of the convex part excluding spring layers.

Unit [mm]

Nominal diameter	Class 900				Class 1500				Class 2500			
	Inner ring I.D. D ₁	Main body		Outer ring O.D. D ₄	Inner ring I.D. D ₁	Main body		Outer ring O.D. D ₄	Inner ring I.D. D ₁	Main body		Outer ring O.D. D ₄
		I.D. D ₂	O.D. D ₃			I.D. D ₂	O.D. D ₃			I.D. D ₂	O.D. D ₃	
1/2	Use a Class 1500 flange gasket.				14.2	19.1	31.8	63.5	14.2	19.1	31.8	69.9
3/4					20.6	25.4	39.6	69.9	20.6	25.4	39.6	76.2
1					26.9	31.8	47.8	79.5	26.9	31.8	47.8	85.9
1 1/4					33.3	39.6	60.5	88.9	33.3	39.6	60.5	104.9
1 1/2					41.4	47.8	69.9	98.6	41.4	47.8	69.9	117.6
2					52.3	58.7	85.9	143.0	52.3	58.7	85.9	146.1
2 1/2					63.5	69.9	98.6	165.1	63.5	69.9	98.6	168.4
3	78.7	95.3	120.7	168.4	78.7	92.2	120.7	174.8	78.7	92.2	120.7	196.9
4	102.6	120.7	149.4	206.5	97.8	117.6	149.4	209.6	97.8	117.6	149.4	235.0
5	128.3	147.6	177.8	247.7	124.5	143.0	177.8	254.0	124.5	143.0	177.8	279.4
6	154.9	174.8	209.6	289.1	147.3	171.5	209.6	282.7	147.3	171.5	209.6	317.5
8	196.9	222.3	257.3	358.9	196.9	215.9	257.3	352.6	196.9	215.9	257.3	387.4
10	246.1	276.4	311.2	435.1	246.1	266.7	311.2	435.1	246.1	270.0	311.2	476.3
12	292.1	323.9	368.3	498.6	292.1	323.9	368.3	520.7	292.1	317.5	368.3	549.4
14	320.8	355.6	400.1	520.7	320.8	362.0	400.1	577.9	—	—	—	—
16	374.7	412.8	457.2	574.8	368.3	406.4	457.2	641.4	—	—	—	—
18	425.5	463.6	520.7	638.3	425.5	463.6	520.7	704.9	—	—	—	—
20	482.6	520.7	571.5	698.5	476.3	514.4	571.5	755.7	—	—	—	—
24	590.6	628.7	679.5	838.2	577.9	616.0	679.5	901.7	—	—	—	—

Vortex™ gaskets with inner and outer rings

■ **Applicable gaskets**

GRASEAL™ vortex, NA vortex, NAFLON™ vortex, vortex gaskets -GS, -GM and -GH

■ **Applicable standard**

JPI-7S-41-1998 "Vortex Gaskets for Pipes" Appendix Table 4 Dimensions

■ **Applicable flange**

JPI-7S-43 "Large Bore Flanges for the Petroleum Industry"
MSS-SP-44 "Steel Pipe Line Flanges"

[Dimension Table 22]

Unit [mm]

Nominal flange diameter	Class 150				Class 300				Class 400			
	Inner ring I.D. D ₁	I.D. D ₂	O.D. D ₃	Outer ring O.D. D ₄	Inner ring I.D. D ₁	I.D. D ₂	O.D. D ₃	Outer ring O.D. D ₄	Inner ring I.D. D ₁	I.D. D ₂	O.D. D ₃	Outer ring O.D. D ₄
26B	654.0	673.1	704.8	774.7	654.0	685.8	736.6	835.2	660.4	685.8	736.6	831.8
28	704.8	723.9	755.6	831.8	704.8	736.6	787.4	898.7	711.2	736.6	787.4	892.3
30	755.6	774.7	806.4	882.6	755.6	793.8	844.6	952.5	755.6	793.8	844.6	946.2
32	806.4	825.5	860.6	939.8	806.4	850.9	901.7	1,006.6	812.8	850.9	901.7	1,003.3
34	857.2	876.3	911.4	990.6	857.2	901.7	952.5	1,057.4	863.6	901.7	952.5	1,054.1
36	908.0	927.1	968.5	1,047.8	908.0	955.8	1,006.6	1,117.6	917.7	955.8	1,006.6	1,117.6
38	958.8	977.9	1,019.3	1,111.2	952.5	977.9	1,016.0	1,054.1	952.5	971.6	1,022.4	1,073.2
40	1,009.6	1,028.7	1,070.1	1,162.0	1,003.3	1,022.4	1,070.1	1,114.6	1,000.3	1,025.7	1,076.5	1,127.3
42	1,060.4	1,079.5	1,124.0	1,219.2	1,054.1	1,073.2	1,120.9	1,165.4	1,051.1	1,076.5	1,127.3	1,178.1
44	1,111.2	1,130.3	1,178.1	1,276.4	1,104.9	1,130.3	1,181.1	1,219.2	1,104.9	1,130.3	1,181.1	1,231.9
46	1,162.0	1,181.1	1,228.9	1,327.2	1,152.7	1,178.1	1,228.9	1,273.3	1,168.4	1,193.8	1,244.6	1,289.0
48	1,212.8	1,231.9	1,279.7	1,384.3	1,209.8	1,235.2	1,286.0	1,324.1	1,206.5	1,244.6	1,295.4	1,346.2
50	1,263.6	1,282.7	1,333.5	1,435.1	1,244.6	1,295.4	1,346.2	1,378.0	1,257.3	1,295.4	1,346.2	1,403.4
52	1,314.4	1,333.5	1,384.3	1,492.2	1,320.8	1,346.2	1,397.0	1,428.8	1,308.1	1,346.2	1,397.0	1,454.2
54	1,358.9	1,384.3	1,435.1	1,549.4	1,352.6	1,403.4	1,454.2	1,492.2	1,352.6	1,403.4	1,454.2	1,517.6
56	1,409.7	1,435.1	1,485.9	1,606.6	1,403.4	1,454.2	1,505.0	1,543.0	1,403.4	1,454.2	1,505.0	1,568.4
58	1,460.5	1,485.9	1,536.7	1,663.7	1,447.8	1,511.3	1,562.1	1,593.8	1,454.2	1,505.0	1,555.8	1,619.2
60	1,511.3	1,536.7	1,587.5	1,714.5	1,524.0	1,562.1	1,612.9	1,644.6	1,517.6	1,568.4	1,619.2	1,682.8

*Use a butt-welded type flange.

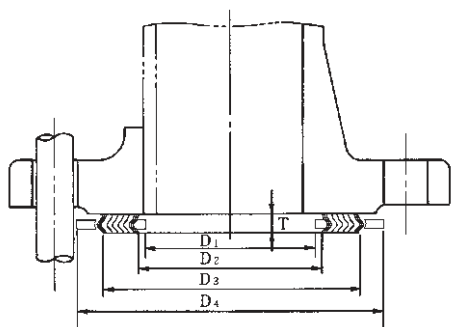

*The O.D. of the body of a gasket with inner and outer rings is expressed as the dimension of the convex part excluding spring layers.

Unit [mm]

Nominal flange diameter	Class 600				Class 900			
	Inner ring I.D. D ₁	I.D. D ₂	O.D. D ₃	Outer ring O.D. D ₄	Inner ring I.D. D ₁	I.D. D ₂	O.D. D ₃	Outer ring O.D. D ₄
26B	647.7	685.8	736.6	866.9	666.8	685.8	736.6	882.6
28	698.5	736.6	787.4	914.4	711.2	736.6	787.4	946.2
30	755.6	793.8	844.6	971.6	774.7	793.8	844.6	1,009.6
32	812.8	850.9	901.7	1,022.4	812.8	850.9	901.7	1,073.2
34	863.6	901.7	952.5	1,073.2	863.6	901.7	952.5	1,136.6
36	917.7	955.8	1,006.6	1,130.3	920.8	958.8	1,009.6	1,200.2
38	952.5	990.6	1,041.4	1,104.9	1,009.6	1,035.0	1,085.8	1,200.2
40	1,009.6	1,047.8	1,098.6	1,155.7	1,060.4	1,098.6	1,149.4	1,251.0
42	1,066.8	1,104.9	1,155.7	1,219.2	1,111.2	1,149.4	1,200.2	1,301.8
44	1,111.2	1,162.0	1,212.8	1,270.0	1,155.7	1,206.5	1,257.3	1,368.6
46	1,162.0	1,212.8	1,263.6	1,327.2	1,219.2	1,270.0	1,320.8	1,435.1
48	1,219.2	1,270.0	1,320.8	1,390.6	1,270.0	1,320.8	1,371.6	1,485.9
50	1,270.0	1,320.8	1,371.6	1,447.8	—	—	—	—
52	1,320.8	1,371.6	1,422.4	1,498.6	—	—	—	—
54	1,378.0	1,428.8	1,479.6	1,555.8	—	—	—	—
56	1,428.8	1,479.6	1,530.4	1,612.9	—	—	—	—
58	1,473.2	1,536.7	1,587.5	1,663.7	—	—	—	—
60	1,530.4	1,593.8	1,644.6	1,733.6	—	—	—	—

Vortex™ gaskets with inner and outer rings

■ Applicable gaskets

GRASEAL™ vortex, NA vortex, NAFLON™ vortex, vortex gaskets -GS, -GM and -GH

■ Applicable flanges*1

TAYLOR FORGE Classes 175, 350, 125, 250, LADISH Classes 150, 300

*1: For TAYLOR FORGE Class 150, use Standard Dimension Table 19.

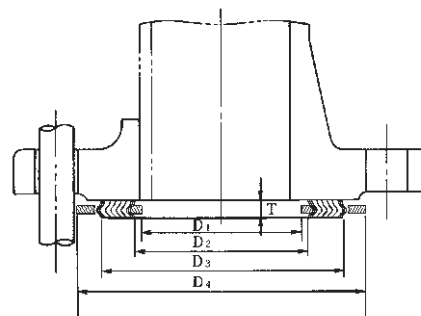

[Dimension Table 23]

Unit [mm]

Nominal flange diameter	TAYLOR FORGE Class 175				TAYLOR FORGE Class 350			
	LADISH Class 150				LADISH Class 300			
	Inner ring I.D. D ₁	I.D. D ₂	O.D. D ₃	Outer ring O.D. D ₄	Inner ring I.D. D ₁	I.D. D ₂	O.D. D ₃	Outer ring O.D. D ₄
26B	660	680	703	740	660	680	712	752
28	711	731	754	791	711	731	763	803
30	762	782	809	848	762	782	814	860
32	813	833	860	899	813	833	865	911
34	864	884	915	952	864	884	916	962
36	914	934	965	1,003	914	934	966	1,026
38	965	985	1,016	1,054	965	985	1,017	1,076
40	1,016	1,041	1,074	1,105	1,016	1,041	1,081	1,127
42	1,067	1,092	1,130	1,165	1,067	1,092	1,132	1,184
44	1,118	1,143	1,181	1,216	1,118	1,143	1,183	1,245
46	1,168	1,193	1,231	1,267	1,168	1,193	1,233	1,295
48	1,219	1,244	1,282	1,318	1,219	1,244	1,284	1,346
50	1,270	1,295	1,333	1,368	—	—	—	—
52	1,321	1,346	1,386	1,426	1,321	1,351	1,401	1,457
54	1,372	1,397	1,437	1,476	1,372	1,402	1,452	1,508
60	1,524	1,549	1,589	1,629	1,524	1,554	1,604	1,661
66	1,676	1,706	1,746	1,781	1,702	1,742	1,782	1,842
72	1,829	1,859	1,899	1,946	1,854	1,894	1,934	1,994
84	2,162	2,202	2,232	2,292	2,197	2,237	2,267	2,327
96	2,467	2,507	2,537	2,597	2,512	2,552	2,582	2,642

Nominal flange diameter	TAYLOR FORGE Class 125				TAYLOR FORGE Class 250			
	Inner ring I.D. D ₁	I.D. D ₂	O.D. D ₃	Outer ring O.D. D ₄	Inner ring I.D. D ₁	I.D. D ₂	O.D. D ₃	Outer ring O.D. D ₄
26B	650	675	725	774	650	675	725	831
28	701	726	776	831	701	726	776	895
30	752	777	827	882	752	777	827	952
32	803	828	878	939	803	828	878	1,009
34	854	879	929	990	854	879	929	1,060
36	904	929	979	1,047	904	929	979	1,117
38	955	985	1,035	1,111	955	985	1,035	1,168
40	1,006	1,036	1,086	1,162	1,006	1,036	1,086	1,225
42	1,057	1,087	1,137	1,219	1,057	1,087	1,137	1,289
44	1,108	1,138	1,188	1,276	1,108	1,138	1,188	1,346
46	1,158	1,188	1,238	1,327	1,158	1,188	1,238	1,403
48	1,209	1,239	1,289	1,384	1,209	1,239	1,289	1,492
50	1,260	1,290	1,340	1,435	—	—	—	—
52	1,311	1,341	1,391	1,492	—	—	—	—
54	1,362	1,392	1,442	1,549	—	—	—	—
60	1,514	1,544	1,594	1,714	—	—	—	—
66	1,745	1,785	1,825	1,885	—	—	—	—
72	1,911	1,951	1,991	2,051	—	—	—	—
84	2,244	2,284	2,314	2,374	—	—	—	—
96	2,568	2,608	2,638	2,698	—	—	—	—

*This dimension table has been prepared by Nichias.

*It is recommended that a gasket fitted with inner and outer rings be used for all nominal pressure values.

*It is recommended that high-strength alloy steel bolts of SNB-7 or higher be used.

GRASEAL™ vortex™ gaskets -L with (inner) outer ring

■ Applicable gasket
GRASEAL vortex -L

■ Applicable flanges
JPI-7S-15 "Flanges for the Petroleum Industry"
ASME B16.5-1998 "Pipe Flanges and Flanged Fittings"
MSS-SP-44-1990 "Steel Pipe Line Flanges"

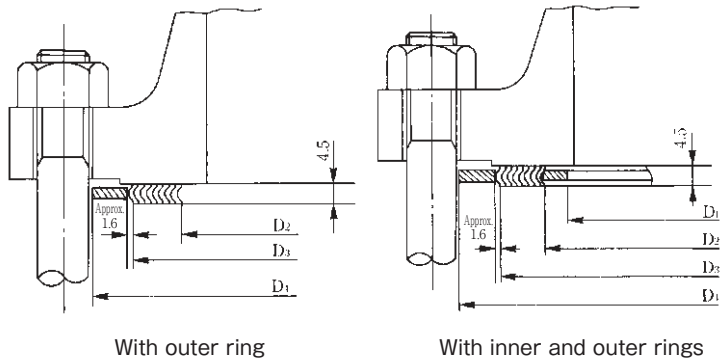

[Dimension Table 24]

Unit [mm]

Nominal diameter	Class 150				Class 300				Class 600			
	Inner ring I.D. D ₁	Main body		Outer ring O.D. D ₄	Inner ring I.D. D ₁	Main body		Outer ring O.D. D ₄	Inner ring I.D. D ₁	Main body		Outer ring O.D. D ₄
		I.D. D ₂	O.D. D ₃			I.D. D ₂	O.D. D ₃			I.D. D ₂	O.D. D ₃	
1/2	17	23	33	47	17	23	33	53	17	23	33	53
3/4	23	29	41	57	23	29	41	66	23	29	41	66
1	30	36	48	66	30	36	48	73	30	36	48	73
1 1/4	41	47	60	76	41	47	60	82	41	47	60	82
1 1/2	45	53	68	85	45	53	68	95	45	53	68	95
2	58	66	82	104	58	66	82	111	58	66	82	111
2 1/2	71	81	97	123	71	81	97	129	71	81	97	129
3	91	101	117	136	91	101	117	148	89	99	117	148
3 1/2	100	112	130	162	100	112	130	164	98	110	130	161
4	115	127	146	174	115	127	146	180	109	121	146	193
5	141	155	175	196	141	153	175	215	135	147	175	241
6	170	186	206	222	166	182	206	250	158	174	206	266
8	220	240	260	279	220	236	260	307	209	230	260	320
10	271	290	314	339	267	287	314	360	254	274	314	400
12	321	347	371	409	321	341	371	420	309	329	371	457
14	351	377	403	450	351	371	403	484	339	366	403	492
16	402	424	460	514	402	422	460	539	392	420	460	564
18	465	487	523	549	455	483	523	595	448	483	523	612
20	514	534	574	606	504	534	574	652	495	534	574	682
24	620	642	682	717	610	642	682	774	603	642	682	790

*This dimension table has been prepared by Nichias.

Ring joint gaskets

Ring joint

■ Applicable gasket

Ring joint gasket "TOMBO No.1850C, 1850V"

■ Applicable standard

JPI-7S-23-1998

"Ring Joint Gaskets for the Petroleum Industry, and Grooves"

■ Applicable flanges

JPI-7S-15 "Forged Steel Flanges for the Petroleum Industry"

JPI-7S-43 "Large Bore Flanges for the Petroleum Industry"

ASME B16.5 "Pipe Flanges and Flanged Fittings"

ANSI B 16.5 "Steel pipe Flange"

API Spec 6A "Wellhead Equipment"

MSS-SP-44 "Steel Pipe Line Flanges"

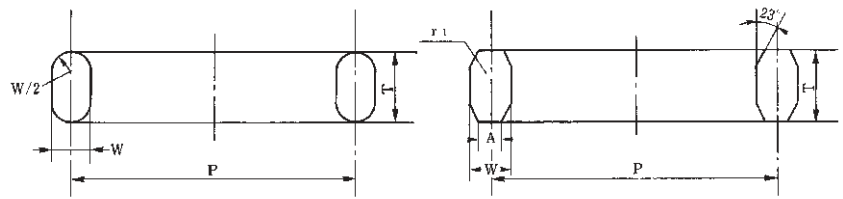

r1: When W is 22.2250 mm or less: 1.59 mm
When W is 25.400 mm or less: 2.38 mm

Oval

Octagonal

[Dimension Table 25]

Unit [mm]

Ring No.	Center diameter of gasket and groove P	Gasket dimensions		
		Gasket width W	Gasket height T	
			Oval	Octagonal
R11	34.14	6.35	11.2	9.7
R12	39.67	7.92	14.2	12.7
R13	42.88	7.92	14.2	12.7
R14	44.45	7.92	14.2	12.7
R15	47.62	7.92	14.2	12.7
R16	50.80	7.92	14.2	12.7
R17	57.15	7.92	14.2	12.7
R18	60.32	7.92	14.2	12.7
R19	65.07	7.92	14.2	12.7
R20	68.28	7.92	14.2	12.7
R21	72.24	11.13	17.5	15.7
R22	82.55	7.92	14.2	12.7
R23	82.55	11.13	17.5	15.7
R24	95.25	11.13	17.5	15.7
R25	101.60	7.92	14.2	12.7
R26	101.60	11.13	17.5	15.7
R27	107.95	11.13	17.5	15.7
R28	111.12	12.70	19.0	17.5
R29	114.30	7.92	14.2	12.7
R30	117.48	11.13	17.5	15.7
R31	123.82	11.13	17.5	15.7
R32	127.00	12.70	19.0	17.5
R33	131.78	7.92	14.2	12.7
R34	131.78	11.13	17.5	15.7
R35	136.52	11.13	17.5	15.7
R36	149.22	7.92	14.2	12.7
R37	149.22	11.13	17.5	15.7
R38	157.18	15.88	22.4	20.6
R39	161.92	11.13	17.5	15.7
R40	171.45	7.92	14.2	12.7
R41	180.98	11.13	17.5	15.7
R42	190.50	19.05	25.4	23.9
R43	193.68	7.92	14.2	12.7
R44	193.68	11.13	17.5	15.7
R45	211.12	11.13	17.5	15.7
R46	211.12	12.70	19.0	17.5
R47	228.60	19.05	25.4	23.9
R48	247.65	7.92	14.2	12.7
R49	269.88	11.13	17.5	15.7

Ring No.	Center diameter of gasket and groove P	Gasket dimensions		
		Gasket width W	Gasket height T	
			Oval	Octagonal
R50	269.88	15.88	22.4	20.6
R51	279.40	22.22	28.4	26.9
R52	304.80	7.92	14.2	12.7
R 53	323.85	11.13	17.5	15.7
R 54	323.85	15.88	22.4	20.6
R 55	342.90	28.58	36.6	35.1
R 56	381.00	7.92	14.2	12.7
R 57	381.00	11.13	17.5	15.7
R 58	381.00	22.22	28.4	26.9
R 59	396.88	7.92	14.2	12.7
R 60	406.40	31.75	39.6	38.1
R 61	419.10	11.13	17.5	15.7
R 62	419.10	15.88	22.4	20.6
R 63	419.10	25.40	33.3	31.8
R 64	454.02	7.92	14.2	12.7
R 65	469.90	11.13	17.5	15.7
R 66	469.90	15.88	22.4	20.6
R 67	469.90	28.58	36.6	35.1
R 68	517.52	7.92	14.2	12.7
R 69	533.40	11.13	17.5	15.7
R 70	533.40	19.05	25.4	23.9
R 71	533.40	28.58	36.6	35.1
R 72	558.80	7.92	14.2	12.7
R 73	584.20	12.70	19.0	17.5
R 74	584.20	19.05	25.4	23.9
R 75	584.20	31.75	39.6	38.1
R 76	673.10	7.92	14.2	12.7
R 77	692.15	15.88	22.4	20.6
R 78	692.15	25.40	33.3	31.8
R 79	692.15	34.92	44.4	41.1
R 80	615.95	7.92	—	12.7
R 81	635.00	14.27	—	19.0
R 82	57.15	11.13	—	15.7
R 84	63.50	11.13	—	15.7
R 85	79.38	12.70	—	17.5
R 86	90.47	15.88	—	20.6
R 87	100.03	15.88	—	20.6
R 88	123.82	19.05	—	23.9
R 89	114.30	19.05	—	23.9
R 90	155.58	22.22	—	26.9
R 91	260.35	31.75	—	38.1
R 92	228.60	11.13	17.5	15.7
R 93	749.30	19.05	—	23.9
R 94	800.10	19.05	—	23.9
R 95	857.25	19.05	—	23.9
R 96	914.40	22.22	—	26.9
R 97	965.20	22.22	—	26.9
R 98	1,022.35	22.22	—	26.9
R 99	234.95	11.13	—	15.7
R100	749.30	28.58	—	35.1
R101	800.10	31.75	—	38.1
R102	857.25	31.75	—	38.1
R103	914.40	31.75	—	38.1
R104	965.20	34.92	—	41.1
R105	1,022.35	34.92	—	41.1

Ring joints

■ **Applicable gaskets**

RX ring joint gaskets

■ **Applicable standard**

API Spec 6A "RX PRESSURE ENERGIZED RING-JOINT GASKETS"

■ **Applicable flange**

API Spec 6A "Wellhead Equipment 6B Flanges"

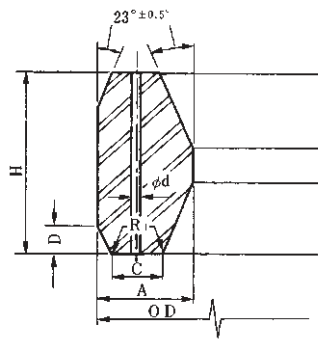

Dimensional tolerances

OD	+0.50 -0.00
A,H	+0.20 -0.00
C	+0.15 -0.00
D	+0.00 -0.80
R ₁	±0.50

[Dimension Table 26]

Unit [mm]

Ring No.	O.D. OD	Width A	Width of flat part C	Height of outer incline D	Height H	R ₁	Hole diameter ϕd
RX- 20	76.20	8.73	4.62	3.18	19.05	1.5	
RX- 23	93.27	11.91	6.45	4.24	25.40	1.5	
RX- 24	105.97	11.91	6.45	4.24	25.40	1.5	
RX- 25	109.54	8.73	4.62	3.18	19.05	1.5	
RX- 26	111.92	11.91	6.45	4.24	25.40	1.5	
RX- 27	118.27	11.91	6.45	4.24	25.40	1.5	
RX- 31	134.54	11.91	6.45	4.24	25.40	1.5	
RX- 35	147.24	11.91	6.45	4.24	25.40	1.5	
RX- 37	159.94	11.91	6.45	4.24	25.40	1.5	
RX- 39	172.64	11.91	6.45	4.24	25.40	1.5	
RX- 41	191.69	11.91	6.45	4.24	25.40	1.5	
RX- 44	204.39	11.91	6.45	4.24	25.40	1.5	
RX- 45	221.85	11.91	6.45	4.24	25.40	1.5	
RX- 46	222.25	13.49	6.68	4.78	28.58	1.5	
RX- 47	245.27	19.84	10.33	6.88	41.28	2.3	
RX- 49	280.59	11.91	6.45	4.24	25.40	1.5	
RX- 50	283.37	16.67	8.51	5.28	31.75	1.5	
RX- 53	334.57	11.91	6.45	4.24	25.40	1.5	
RX- 54	337.34	16.67	8.51	5.28	31.75	1.5	
RX- 57	391.72	11.91	6.45	4.24	25.40	1.5	
RX- 63	441.72	26.99	14.78	8.46	50.80	2.3	
RX- 65	480.62	11.91	6.45	4.24	25.40	1.5	
RX- 66	483.39	16.67	8.51	5.28	31.75	1.5	
RX- 69	544.12	11.91	6.45	4.24	25.40	1.5	
RX- 70	550.07	19.84	10.34	6.88	41.28	2.3	
RX- 73	596.11	13.49	6.68	5.28	31.75	1.5	
RX- 74	600.87	19.84	10.34	6.88	41.28	2.3	
RX- 82	67.87	11.91	6.45	4.24	25.40	1.5	1.5
RX- 84	74.22	11.91	6.45	4.24	25.40	1.5	1.5
RX- 85	90.09	13.49	6.68	4.24	25.40	1.5	1.5
RX- 86	103.58	15.08	8.51	4.78	28.58	1.5	1.5
RX- 87	113.11	15.08	8.51	4.78	28.58	1.5	1.5
RX- 88	139.30	17.46	10.34	5.28	31.75	1.5	3.0
RX- 89	129.78	18.26	10.34	5.28	31.75	1.5	3.0
RX- 90	174.63	19.84	12.17	7.42	44.45	2.3	3.0
RX- 91	286.94	30.16	19.81	7.54	45.24	2.3	3.0
RX- 99	245.67	11.91	6.45	4.24	25.40	1.5 ^{*2}	
RX-201	51.46	5.74	3.20	1.45	11.30	0.5 ^{*2}	
RX-205	62.31	5.56	3.05	1.83 ^{*1}	11.10	0.5 ^{*2}	
RX-210	97.63	9.53	5.41	3.18 ^{*1}	19.05	0.8 ^{*2}	
RX-215	140.89	11.91	5.33	4.24 ^{*1}	25.40	1.5 ^{*2}	

*1: Dimensional tolerance +0, -0.38 *2: Dimensional tolerance +0.5, -0

*From RX-82 to RX-91, there is a pressure relief hole in the ring.

*The finish of the gasket sealing face must be at least 63RMS.

Ring joints

■ Applicable gaskets

BX type ring joint gaskets

■ Applicable standard

API Spec 6A-1977 BX
"PRESSURE ENERGIZED RINGJOINTGASKETS"

■ Applicable flange

API Spec 6A
"Wellhead Equipment 6BX Flanges"

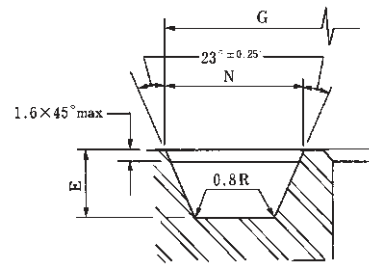
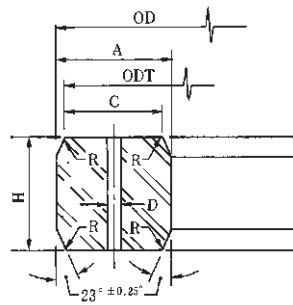

Dimensional tolerances

OD	+0.0 -0.15
H,A	+0.20 -0
ODT	±0.05
C	+0.15 -0
E	+0.50 -0
G,N	+0.10 -0.0

[Dimension Table 27]

Unit [mm]

Ring No.	Gasket dimensions							Groove dimensions		
	O.D. OD	Height H	Width A	O.D. of flat part ODT	Width of flat part C	Hole diameter ϕd	R	Depth E	O.D. G	Width N
BX-150	72.19	9.30	9.30	70.87	7.98	1.59	8 - 12% of gasket height H	5.56	73.48	11.43
BX-151	76.40	9.63	9.63	75.03	8.26	1.59		5.56	77.79	11.84
BX-152	84.68	10.24	10.24	83.24	8.79	1.59		5.95	86.23	12.65
BX-153	100.94	11.38	11.38	99.31	9.78	1.59		6.75	102.77	14.07
BX-154	116.84	12.40	12.40	115.09	10.64	1.59		7.54	119.00	15.39
BX-155	147.96	14.22	14.22	145.95	12.22	1.59		8.33	150.62	17.73
BX-169	173.51	15.85	12.93	171.27	10.69	1.59		9.53	176.66	16.92
BX-156	237.92	18.62	18.62	235.28	15.98	3.18		11.11	241.83	23.39
BX-157	294.46	20.98	20.98	291.49	18.01	3.18		12.70	299.06	26.39
BX-158	352.04	23.14	23.14	348.77	19.86	3.18		14.29	357.23	29.18
BX-159	426.72	25.70	25.70	423.09	22.07	3.18		15.88	432.64	32.49
BX-160	402.59	23.83	13.74	399.21	10.36	3.18		14.29	408.00	19.96
BX-161	491.41	28.07	16.21	487.45	12.24	3.18		17.07	497.94	23.62
BX-162	475.49	14.22	14.22	473.48	12.22	1.59		8.33	478.33	17.91
BX-163	556.16	30.10	17.37	551.89	13.11	3.18		18.26	563.50	25.55
BX-164	570.56	30.10	24.59	566.29	20.32	3.18		18.26	577.90	32.77
BX-165	624.71	32.03	18.49	620.19	13.97	3.18		19.05	632.56	27.20
BX-166	640.03	32.03	26.14	635.51	21.62	3.18		19.05	647.88	34.87
BX-167	759.36	35.87	13.11	754.28	8.03	1.59	21.43	768.33	22.91	
BX-168	765.25	35.87	16.05	760.17	10.97	1.59	21.43	774.22	25.86	

*There is one pressure relief hole on the centerline of the gasket.
*The finish of the gasket sealing face must be at least 32RMS.

Collation of Ring No., nominal flange diameter and nominal pressure

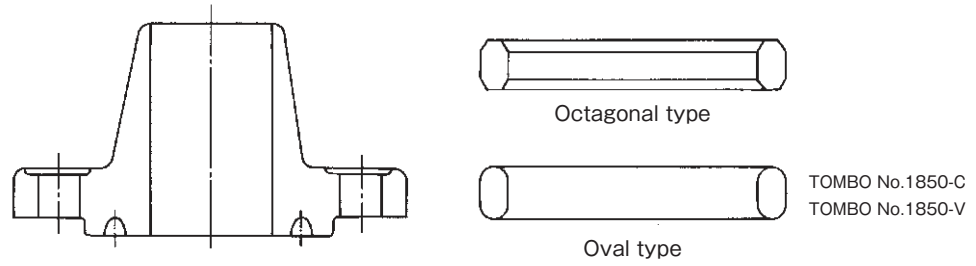

[Dimension Table 28]

Unit [mm]

Nominal flange diameter	Applicable flange										
	JPI-7S-15, ANSI B 16.5					API Spec 6A				MSS SP-44	
	Class 150	300, 400 600	900	1500	2500	960	2000	3000	5000	300, 400 600	900
1/2 B	—	R11	R12	R12	R13	—	—	—	—	—	—
3/4	—	R13	R14	R14	R16	—	—	—	—	—	—
1	R15	R16	R16	R16	R18	—	—	—	—	—	—
1 1/4	R17	R18	R18	R18	R21	—	—	—	—	—	—
1 1/2	R19	R20	R20	R20	R23	—	R20	R20	R20	—	—
2	R22	R23	R24	R24	R26	—	R23	R24	R24	—	—
2 1/2	R25	R26	R27	R27	R28	—	R26	R27	R27	—	—
3	R29	R30 ^{*1} R31	R31	R35	R32	—	R31	R31	R35	—	—
3 1/2	R33	R34	—	—	—	—	—	—	—	—	—
4	R36	R37	R37	R39	R38	—	R37	R37	R39	—	—
5	R40	R41	R41	R44	R42	—	R41	R41	—	—	—
6	R43	R45	R45	R46	R47	R45	R45	R45	R46	—	—
8	R48	R49	R49	R50	R51	R49	R49	R49	R50	—	—
10	R52	R53	R53	R54	R55	R53	R53	R53	R54	—	—
12	R56	R57	R57	R58	R60	R57	R57	R57	—	R57	R57
14	R59	R61	R62	R63	—	—	—	—	R63	R61	R62
16	R64	R65	R66	R67	—	R65	R65	R66	—	R65	R66
18	R68	R69	R70	R71	—	—	R69	R70	—	R69	R70
20	R72	R73	R74	R75	—	R73	R73	R74	—	R73	R74
22	—	—	—	—	—	—	—	—	—	R81	—
24	R76	R77	R78	R79	—	—	—	—	—	R77	R78
26	—	R93	R100	—	—	—	—	—	—	R93	R100
28	—	R94	R101	—	—	—	—	—	—	R94	R101
30	—	R95	R102	—	—	—	—	—	—	R95	R102
32	—	R96	R103	—	—	—	—	—	—	R96	R103
34	—	R97	R104	—	—	—	—	—	—	R97	R104
36	—	R98	R105	—	—	—	—	—	—	R98	R105

*1: R30 applies only to a lapped joint.

*For the same groove (same R No.), either an oval type or an octagonal may be used.

NAFLON™ PTFE cushion gaskets (TOMBO No.9010-NA-A/B)

■ **Applicable gaskets**
 NAFLON PTFE cushion gaskets
 *TOMBO No.9010-NA-A, 9010-NA-B"

■ **Applicable standard**
 (Old) JIS B 2238-1996 "General Rules for Steel Pipe Flanges"

■ **Applicable flanges**
 JIS B 2220-2004 "Steel Pipe Flanges"
 (Old) JIS B 2238-1996 "General Rules for Steel Pipe Flanges"

*This dimension table has been prepared by Nichias based on (Old) JIS B 2238-1996.

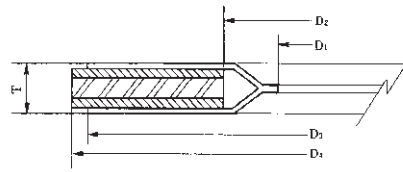

Type A-6, type A-8

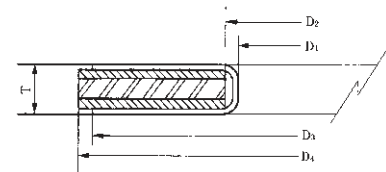

Type B-6, type B-8

[Dimension Table 29]

Unit [mm]

Nominal flange diameter		D ₁	D ₂	5K		10K (standard)		16K		20K		T	Type No.
A	B			D ₃	D ₄	D ₃	D ₄	D ₃	D ₄	D ₃	D ₄		
10	3/8	18	26	42	45	49	53	48	53	49	53	3.2 (2.8)	Type A
15	1/2	22	30	46	50	54	58	52	58	54	58		
20	3/4	28	36	52	55	59	63	58	63	59	63		
25	1	35	43	59	65	70	74	70	74	70	74		
32	1 1/4	43	51	71	78	79	84	79	84	79	84		
40	1 1/2	49	57	77	83	85	89	85	89	85	89		
50	2	62	69	88	93	99	104	100	104	99	104		
65	2 1/2	78	85	106	118	119	124	116	124	119	124		
80	3	91	98	121	129	129	134	135	140	135	140		
90	3 1/2	104	111	134	139	140	144	145	150	148	150		
100	4	117	124	145	149	155	159	160	165	163	165		
125	5	144	151	178	184	185	190	195	203	198	203		
150	6	171	178	205	214	215	220	227	238	233	238		
175	7	193	200	229	240	240	245	—	—	—	—		
200	8	219	226	255	260	265	270	275	283	278	283		
225	9	244	251	280	285	285	290	—	—	—	—		
250	10	271	278	313	325	321	333	345	356	345	356		
300	12	321	328	363	370	370	378	395	406	395	406		
350	14	356	363	401	413	415	423	436	450	436	450		
400	16	407	414	461	473	471	486	487	510	487	510		
450	18	457	464	511	533	530	541	556	575	556	575		
500	20	510	517	571	583	583	596	609	630	609	630		
550	22	561	568	625	641	635	650	665	684	665	684		
600	24	612	619	676	691	684	700	716	734	716	734		
650	26	670	674	735	746	740	750	770	784	790	805		
700	28	725	729	785	796	800	810	820	836	840	855		
750	30	775	779	840	850	855	870	880	896	900	918		
800	32	825	829	890	900	905	920	930	945	960	978		
850	34	875	879	940	950	955	970	980	995	1,020	1,038		
900	36	925	929	990	1,000	1,005	1,020	1,030	1,045	1,070	1,088		
1,000	40	1,030	1,034	1,090	1,100	1,110	1,124	1,140	1,158	—	—	3.2 (3.8)	Type B
1,100	44	1,130	1,134	1,200	1,210	1,220	1,234	1,240	1,258	—	—		
1,200	48	1,230	1,234	1,305	1,320	1,325	1,344	1,350	1,368	—	—		
1,300	52	1,335	1,339	—	—	—	—	1,450	1,474	—	—		
1,350	54	1,390	1,394	1,460	1,475	1,480	1,498	1,510	1,534	—	—		
1,400	56	1,435	1,439	—	—	—	—	1,560	1,584	—	—		
1,500	60	1,545	1,549	1,615	1,630	1,635	1,658	1,670	1,694	—	—		

*Dimensions in parentheses () are applicable to TOMBO No.9010-NA-A-5 and 9010-NA-A-7, and also to 9010-NA-B-5 and 9010-NA-B-7.

*Inside bold border □ : Cannot be used for type B nominal diameter 10 - 50A of JIS B 2220 nominal pressure 20K slip-on welded flanges.

For JPI pipe flanges

NAFLON™ PTFE cushion gaskets (TOMBO No.9010-NA-A/B)

■ **Applicable gaskets**
 NAFLON PTFE cushion gaskets
 "TOMBO No.9010-NA-A, 9010-NA-B"

■ **Applicable standards**
 JPI-7S-15-1999 (Class 150, 24B or lower)
 "Forged Steel Flanges for the Petroleum Industry"
 JPI-7S-43-2001 (Class 300, 26B or higher)*1
 "Large Bore Flanges for the Petroleum Industry"

■ **Applicable flanges**
 JPI-15 "Forged Steel Flanges for the Petroleum Industry"
 JPI-7S-43 "Large Bore Flanges for the Petroleum Industry"
 ASME B16.5 "Pipe Flanges and Flanged Fittings"
 ANSI B 16.5 "Steel pipe Flange"
 API-Std 605 "Standard for Large-Diameter Carbon Steel Flanges"

*1: The dimensions for 26B and higher and class 300 have been prepared by Nichias based on JPI-7S-43-2001.

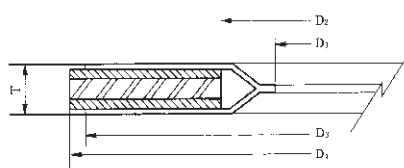

Type A-6, type A-8

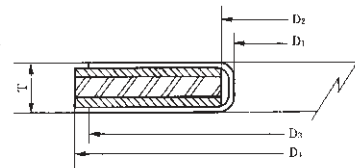

Type B-6, type B-8

[Dimension Table 30]

Unit [mm]

Nominal flange diameter	D ₁	D ₂	Class 75		Class 150		Class 300		T	Type No.
			D ₃	D ₄	D ₃	D ₄	D ₃	D ₄		
1/2 B	17	24	—	—	36	47	36	53	3.2 (2.8)	Type A
3/4	22	29	—	—	44	56	44	66		
1	28	35	—	—	52	66	52	72		
1 1/4	36	43	—	—	65	75	65	82		
1 1/2	42	49	—	—	74	85	74	94		
2	53	60	—	—	92	104	92	110		
2 1/2	66	73	—	—	105	123	105	129		
3	90	97	—	—	127	135	127	148		
3 1/2	103	110	—	—	140	161	140	164		
4	116	123	—	—	157	173	157	180		
5	143	150	—	—	186	196	186	215		
6	169	176	—	—	216	221	216	250		
8	220	227	—	—	270	277	270	306		
10	275	282	—	—	324	338	324	360		
12	326	333	—	—	381	408	381	420		
14	358	365	—	—	413	449	413	484		
16	408	415	—	—	470	512	470	538		
18	459	466	—	—	533	547	533	595		
20	510	517	—	—	584	604	584	651		
24	612	619	—	—	692	715	692	772		
26	673	677	705	705	711	722	737	769		
28	724	728	756	756	762	773	787	822		
30	775	779	806	807	813	824	845	883		
32	826	830	857	857	864	878	902	937		
34	876	880	908	908	921	932	952	991		
36	927	931	965	970	972	984	1,010	1,045		
38	978	982	1,016	1,021	1,022	1,042	1,060	1,096		
40	1,029	1,033	1,067	1,072	1,080	1,092	1,118	1,146		
42	1,080	1,084	1,118	1,123	1,130	1,143	1,168	1,197		
44	1,130	1,134	1,168	1,178	1,187	1,194	1,219	1,248		
46	1,181	1,185	1,226	1,229	1,238	1,253	1,276	1,315		
48	1,232	1,236	1,276	1,280	1,289	1,304	1,327	1,365		
54	1,384	1,388	1,429	1,435	1,441	1,461	1,480	1,527		
60	1,537	1,541	1,588	1,594	1,600	1,625	1,651	1,702		

*Dimensions in parentheses () are applicable to TOMBO No.9010-NA-A-5 and 9010-NA-A-7, and also to 9010-NA-B-5 and 9010-NA-B-7.

*Inside bold border □: These cannot be used for a JPI-7S-15 slip-on type flange that has a nominal diameter of 2 1/2 B (65A) or less because the gasket I.D. (D1) is inward of the flange I.D.

NAFLON™ PTFE cushion gaskets (TOMBO No.9010-NA-B)

■ Applicable gaskets

NAFLON PTFE cushion gasket "TOMBO No.9010-NA-B"

■ Applicable flanges

ASME/ANSI B 16.1 "Cast Iron Pipe Flanges and Flanged Fittings"
TAYLOR FORGE flange (Values marked ☆ in the dimension table are applicable to a TAYLOR FORGE flange.)

*This dimension table has been prepared by Nichias based on the above applicable flange.

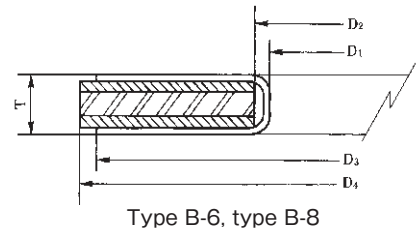

[Dimension Table 31]

Unit [mm]

Nominal flange diameter		D ₁	D ₂	Class 125		Class 250		T	Type No.
A	B			D ₃	D ₄	D ₃	D ₄		
650	26☆	673	677	767	775	824	832	3.2 (3.8)	Type B
700	28☆	724	728	824	832	887	895		
750	30	775	779	875	883	945	952		
800	32☆	826	830	932	940	1,002	1,010		
850	34☆	876	880	983	991	1,053	1,060		
900	36	927	931	1,040	1,048	1,110	1,118		
950	38☆	978	982	1,103	1,111	1,160	1,168	5.0 (3.8)	
1,000	40☆	1,029	1,033	1,154	1,162	1,218	1,226		
1,050	42	1,080	1,084	1,211	1,219	1,281	1,289		
1,100	44☆	1,130	1,134	1,268	1,276	1,338	1,346		
1,150	46☆	1,181	1,185	1,319	1,327	1,395	1,403		
1,200	48	1,232	1,236	1,376	1,384	1,484	1,492		
1,250	50☆	1,283	1,287	1,427	1,435	—	—		
1,300	52☆	1,334	1,338	1,484	1,492	—	—		
1,350	54	1,384	1,388	1,541	1,549	—	—		
1,500	60	1,537	1,541	1,707	1,714	—	—		
1,650	66☆	1,689	1,693	1,878	1,886	—	—		
1,800	72	1,842	1,846	2,043	2,051	—	—		
2,100	84	2,146	2,150	2,367	2,375	—	—		
2,400	96	2,451	2,455	2,691	2,699	—	—		

*Dimensions in parentheses () are applicable to TOMBO No.9010-NA-B-5 and 9010-NA-B-7.

For MSS pipe flanges

NAFLON™ PTFE cushion gaskets (TOMBO No.9010-NA-B)

■ Applicable gaskets

NAFLON PTFE cushion gaskets "TOMBO No.9010-NA-B"

■ Applicable flanges

MSS SP-44 "Steel Pipe Line Flanges"

*This dimension table has been prepared by Nichias based on MSS SP-44-1996.

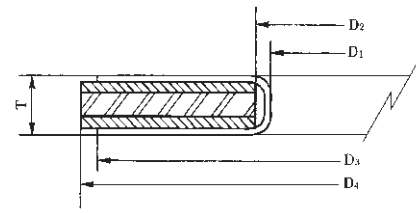

Type B-6, type B-8

[Dimension Table 32]

Unit [mm]

Nominal flange diameter		D ₁	D ₂	Class 150		Class 300		T	Type No.
A	B			D ₃	D ₄	D ₃	D ₄		
650	26	673	677	749	775	749	835	3.2 (3.8)	Type B
700	28	724	728	800	832	800	899		
750	30	775	779	857	883	857	952		
800	32	826	830	914	940	914	1,006		
850	34	876	880	965	991	965	1,057		
900	36	927	931	1,022	1,048	1,022	1,118		
950	38	978	982	1,073	1,111	1,029	1,054	5.0 (3.8)	
1,000	40	1,029	1,033	1,124	1,162	1,086	1,114		
1,050	42	1,080	1,084	1,194	1,219	1,137	1,165		
1,100	44	1,130	1,134	1,245	1,276	1,194	1,219		
1,150	46	1,181	1,185	1,295	1,327	1,245	1,273		
1,200	48	1,232	1,236	1,359	1,384	1,302	1,324		
1,250	50	1,283	1,287	1,410	1,435	1,359	1,378		
1,300	52	1,334	1,338	1,460	1,492	1,410	1,429		
1,350	54	1,384	1,388	1,511	1,549	1,467	1,492		
1,400	56	1,435	1,439	1,575	1,607	1,518	1,543		
1,450	58	1,486	1,490	1,626	1,664	1,575	1,594		
1,500	60	1,537	1,541	1,676	1,714	1,626	1,645		

*Dimensions in parentheses () are applicable to TOMBO No.9010-NA-B-5 and 9010-NA-B-7.

NAFLON™ PTFE cushion gaskets (TOMBO No.9010-NA-AS)

■ Applicable gaskets
NAFLON PTFE cushion gaskets "TOMBO No.9010-NA-AS"

■ Applicable standard *1
(Old) JIS B 2238-1996

■ Applicable flanges
JIS B 2220-2004 "Steel Pipe Flanges"
(Old) JIS B 2238-1996 "General Rules for Steel Pipe Flanges"

*1: This dimension table has been prepared by Nichias based on JIS B 2238-1996.

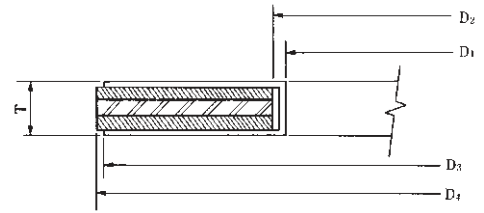

Type AS-6, type AS-8

[Dimension Table 33]

Unit [mm]

Nominal flange diameter		D ₁	D ₂	5K		10K (standard)		16K, 20K		T	Type No.
A	B			D ₃	D ₄	D ₃	D ₄	D ₃	D ₄		
10	3/8	26	28	42	45	48	53	48	53	2.5 (2.5)	Type AS
15	1/2	31	33	48	50	52	58	52	58		
20	3/4	36	38	52	55	58	63	58	63		
25	1	41	43	62	65	70	74	70	74		
32	1 1/4	51	53	72	78	80	84	80	84		
40	1 1/2	56	58	78	83	85	89	85	89		
50	2	67	70	88	93	100	104	100	104	3.4 (3.0)	
65	2 1/2	92	95	112	118	120	124	120	124		
80	3	102	105	125	129	130	134	135	140		
90	3 1/2	112	115	135	139	140	144	145	150		
100	4	122	125	145	149	155	159	160	165		
125	5	152	155	180	184	185	190	195	203		
150	6	187	190	210	214	215	220	230	238		
175	7	207	210	235	240	240	245	—	—		
200	8	232	235	255	260	265	270	275	283		
225	9	257	260	280	285	285	290	—	—		
250	10	297	300	320	325	325	333	345	356		
300	12	337	340	365	370	370	378	395	406		
350	14	377	380	405	413	415	423	440	450		
400	16	427	430	465	473	475	486	495	510		
450	18	477	480	525	533	530	541	560	575		
500	20	527	530	575	583	585	596	615	630		
550	22	577	580	630	641	640	650	670	684		
600	24	627	630	680	691	690	700	720	734		

*This gasket cannot be used for type B, nominal diameter 10 - 50A of JIS B 2220, nominal pressure 20K, slip-on welded flanges because the gasket I.D. (D1) is inward of the flange I.D.

*Dimensions in parentheses () are applicable to TOMBO No.9010-NA-AS-5 and 9010-NA-AS-7.

For JPI pipes flanges

NAFLON™ PTFE cushion gaskets (TOMBO No.9010-NA-AS)

■ Applicable gaskets

NAFLON PTFE cushion gasket "TOMBO No.9010-NA-AS"

■ Applicable flanges

JPI-7S-15 "Forged Steel Flanges for the Petroleum Industry"
 API-Std 605 "Standard for Large-Diameter Carbon Steel Flanges"
 ASME B16.5 "Pipe Flanges and Flanged Fittings"
 ANSI B 16.5 "Steel pipe Flange"

*This dimension has been prepared by Nichias based on JPI 7S-15-1999.

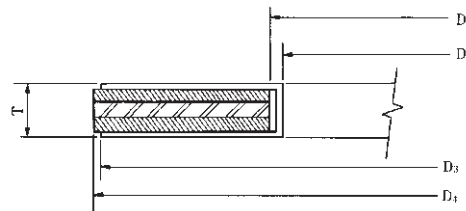

Type AS-6, type AS-8

[Dimension Table 34]

Unit [mm]

Nominal flange diameter		D ₁	D ₂	Class 150			Class 300			Type No.
A	B			D ₃	D ₄	T	D ₃	D ₄	T	
15	1/2	21	24	47	47	2.5 (2.8)	36	53	2.5 (2.5)	Type AS
20	3/4	26	29	56	56		44	66		
25	1	32	35	66	66		52	72		
32	1 1/4	40	43	75	75		65	82		
40	1 1/2	46	49	85	85		74	94		
50	2	57	60	92	104	92	110	3.4 (3.0)		
65	2 1/2	70	73	105	123	105	129			
80	3	94	97	127	135	127	148			
90	3 1/2	107	110	140	161	140	164			
100	4	120	123	157	173	157	180			
125	5	147	150	186	196	186	215	3.4 (3.0)		
150	6	173	176	216	221	216	250			
200	8	224	227	270	277	270	306			
250	10	279	282	324	338	324	360			
300	12	330	333	381	408	381	420			
350	14	362	365	413	449	413	484	3.4 (3.0)		
400	16	412	415	470	512	470	538			
450	18	463	466	533	547	533	595			
500	20	514	517	584	604	584	651			
600	24	616	619	692	715	692	772			

*Dimensions in parentheses () are applicable to TOMBO No.9010-NA-AS-5 and 9010-NA-AS-7.

NAFLON™ PTFE cushion gaskets (TOMBO No.9010-NA-FG-7)

■ Applicable gaskets

NAFLON PTFE cushion gasket "TOMBO No.9010-NA-FG-7"

■ Applicable flanges

For fluoro-piping JIS standard dimension 10K and ASME (JPI) Class 150

*TOMBO No.9010-NA-FG-7 is a PTFE jacketed gasket which is used in our corrosion resistant fluoro-piping.

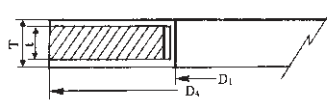

Type AS-7

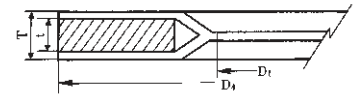

Type A-7

[Dimension Table 35]

Unit [mm]

Nominal flange diameter		For JIS 10K				For ANSI (JPI) Class 150				Type No.
A	B	D ₁	D ₄	t	T	D ₁	D ₄	t	T	
15	1/2	16	58	1.5	2.3	16	47	1.5	2.3	Type AS-7
20	3/4	22	63			22	56			
25	1	27	74			28	66			
40	1 1/2	45	89			45	85			
50	2	58	104			58	104			
65	2 1/2	71	124			71	123			
80	3	85	134			85	135			Type A-7
100	4	104	159			110	173			
125	5	128	189			128	196			
150	6	153	220			160	221			
200	8	202	270			214	277			
250	10	251	333			266	338			
300	12	300	378			328	408			

If a solid gasket is desired, use NAFLON PTFE cut gaskets (TOMBO No.9007) or NAFLON special filler filled PTFE gaskets (TOMBO No.9007-LC) shown in the figure below. D₁, D₂ and t are based on the Dimension table 37.

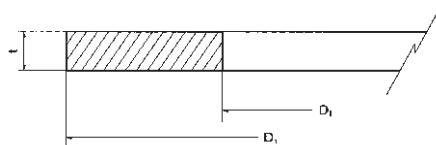

NAFLON PTFE cut gasket (TOMBO No.9007)

NAFLON special filler filled PTFE gasket (TOMBO No.9007-LC)

For glass-lined flange (JIS dimensions)

NAFLON™ PTFE cushion gaskets (TOMBO No.9010-NA-GL-5, 6, 7 and 8 [Type A])

■ Applicable gaskets

NAFLON PTFE cushion gasket (TOMBO No.9010-NA-A-5, 6, 7, 8)

■ Applicable flange

GL JIS flange (AGC Techno Glass Co., Ltd.)

*This dimension table has been prepared by Nichias based on the dimensions of the above flange.

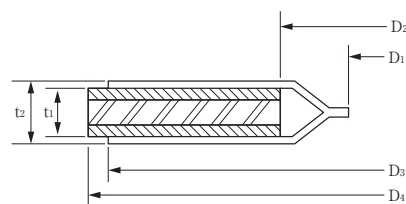

[Dimension Table 36]

Unit [mm]

Nominal flange diameter	D ₁	D ₂	D ₃	D ₄	t ₁	t ₂
A						
20	19	29	61	63	2.0 (2.4)	2.8 (3.2)
25	25	35	72	74		
40	38	48	87	89		
50	50	60	102	104		
65	65	75	122	124		
80	77	87	132	134		
100	103	113	157	159		
150	153	163	219	220		
200	201	211	269	270		

*The dimensions of glass-lined flanges differ from one manufacturer to another, so when you intend to use a non-applicable flange, please consult us.

*The values in parentheses () apply to TOMBO No.9010-NA-GL-6, 8.

*The standard setting of the core of AGC Techno Glass is TOMBO No.9010-NA-GL-5, 7.

NAFLON™ PTFE cushion gaskets (TOMBO No.9010-NA-GL-5, 6, 7 and 8 [Type A])

■ **Applicable gaskets**

NAFLON PTFE cushion gaskets (TOMBO No.9010-NA-A-5, 6, 7 and 8)

■ **Applicable flange**

GL JPI flange (AGC Techno Glass Co., Ltd.)

*This dimension table has been prepared by Nichias based on the dimensions of the above flange.

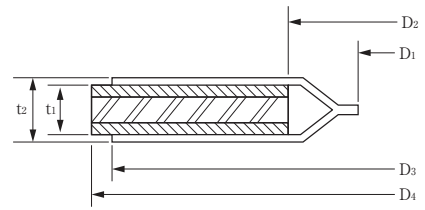

[Dimension Table 37]

Unit [mm]

Nominal diameter (A)	D ₁	D ₂	D ₃	D ₄	t ₁	t ₂
20	19	29	56	58	2.0 (2.4)	2.8 (3.2)
25	25	35	65	67.5		
40	38	48	84	86.5		
50	50	60	102	104.5		
65	65	75	122	123.5		
80	77	87	134	136.5		
100	103	113	172	174.5		
150	153	163	220	221.5		
200	201	211	276	278.5		

*The dimensions of glass-lined flanges differ from one manufacturer to another, so when you intend to use a non-applicable flange, please consult us.

*The values in parentheses () apply to TOMBO No.9010-NA-GL-6, 8.

*The standard setting of the core of AGC Techno Glass is TOMBO No.9010-NA-GL-5, 7.

For JIS pipe flanges

NAFLON™ PTFE cushion gaskets [Fully-covered] (TOMBO No.9010-NA-R-A)

■ Applicable gaskets

NAFLON PTFE cushion gaskets [Fully-covered]
"TOMBO No.9010-NA-R-A"

■ Applicable standard *1

(Old) JIS B 2238-1996

■ Applicable flanges

JIS B 2220-2004 "Steel Pipe Flanges"

(Old) JIS B 2238-1996 "General Rules for Steel Pipe Flanges"

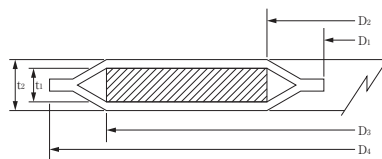

Type A-7

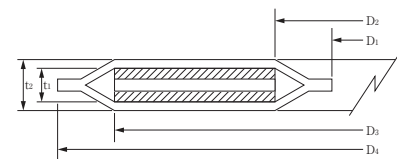

Type A-8

*1: This dimension table has been prepared by Nichias based
on (Old) JIS B 2238-1996.

[Dimension Table 38]

Unit [mm]

Nominal flange diameter	D ₁	D ₂	D ₃		D ₄		t ₁	t ₂
			Nominal pressure K		Nominal pressure K			
			5	10	5	10		
A								
10	13	20	33	41	45	53	2.0 (2.4)	28 (3.2)
15	17	24	38	46	50	58		
20	22	29	43	51	55	63		
25	28	35	53	62	65	74		
32	36	43	66	72	78	84		
40	42	49	71	77	83	89		
50	53	60	81	92	93	104		
65	66	73	106	112	118	124		
80	79	86	117	122	129	134		
90	91	98	127	132	139	144		
100	103	110	137	147	149	159		
125	135	142	172	178	184	190		
150	162	169	202	208	214	220		
175	184	191	228	233	240	245		
200	210	217	248	258	260	270		
225	236	243	273	278	285	290		
250	270	277	313	321	325	333		
300	316	323	358	366	370	378		
350	351	358	401	411	413	423		
400	410	417	461	474	473	486		
450	455	462	521	529	533	541		
500	511	518	571	584	583	596		
550	564	571	629	638	641	650		
600	616	623	679	688	691	700		

*Dimensions in parentheses () are applicable to TOMBO No.9010-NA-A-6 and 9010-NA-A-8.

NAFLON™ PTFE cushion gaskets [Fully-covered] (TOMBO No.9010-NA-R-AS)

■ **Applicable gaskets**
 NAFLON PTFE cushion gaskets [Fully-covered]
 "TOMBO No.9010-NA-R-AS"

■ **Applicable standard** *1
 (Old) JIS B 2238-1996

■ **Applicable flanges**
 JIS B 2220-2004 "Steel Pipe Flanges"
 (Old) JIS B 2238-1996 "General Rules for Steel Pipe Flanges"

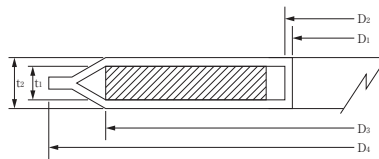

Type AS-7

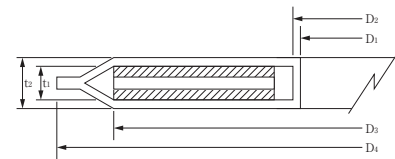

Type AS-8

*1: This dimension table has been prepared by Nichias based on (Old) JIS B 2238-1996.

[Dimension Table 39]

Unit [mm]

Nominal flange diameter	D ₁	D ₂	D ₃		D ₄		t ₁	t ₂
			Nominal pressure K		Nominal pressure K			
			5	10	5	10		
A								
10	13	16	33	41	45	53	2.0 (2.4)	3.0 (3.4)
15	17	20	38	46	50	58		
20	22	25	43	51	55	63		
25	28	31	53	62	65	74		
32	36	39	66	72	78	84		
40	42	45	71	77	83	89		
50	53	56	81	92	93	104		
65	66	69	106	112	118	124		
80	79	82	117	122	129	134		
90	91	94	127	132	139	144		
100	103	106	137	147	149	159		
125	143	146	172	178	184	190		
150	179	182	202	208	214	220		
175	198	201	228	233	240	245		
200	224	227	248	258	260	270		
225	249	252	273	278	285	290		
250	292	295	313	321	325	333		
300	332	335	358	366	370	378		
350	372	375	401	411	413	423		
400	425	428	461	474	473	486		
450	475	478	521	529	533	541		
500	525	528	571	584	583	596		
550	574	577	629	638	641	650		
600	624	627	679	688	691	700		

*Dimensions in parentheses () are applicable to TOMBO No.9010-NA-AS-6 and 9010-NA-AS-8.

For JIS pipe flanges

NAFLON™ PTFE cushion gasket [High-temperature type] (TOMBO No.9010-NA-A-9)

■ **Applicable gaskets**

NAFLON PTFE cushion gaskets [high-temperature type]
"TOMBO No.9010-NA-A-9"

■ **Applicable standard** *1

(Old) JIS B 2238-1996

■ **Applicable flanges**

JIS B 2220-2004 "Steel Pipe Flanges"

(Old) JIS B 2238-1996 "General Rules for Steel Pipe Flanges"

*1: This dimension table has been prepared by Nichias based on (Old) JIS B 2238-1996.

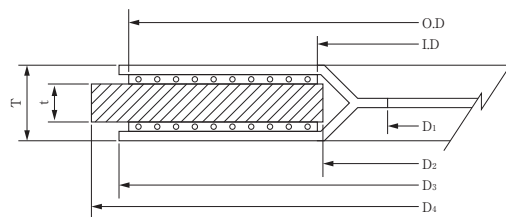

Type A

[Dimension Table 40]

Unit [mm]

Nominal flange diameter		D ₁	D ₂	10K (standard)				16, 20K				t	T	Shape
A	B			D ₃	D ₄	Mesh		D ₃	D ₄	Mesh				
						I.D	O.D			I.D	O.D			
(10)	3/8	18	26	49	53	30	47	49	53	30	47	2.0	3.9	Type A
(15)	1/2	22	30	54	58	34	52	54	58	34	52			
(20)	3/4	28	36	59	63	40	57	59	63	40	57			
25	1	35	43	70	74	47	68	70	74	47	68			
32	1 1/4	43	51	79	84	55	77	79	84	55	77			
40	1 1/2	49	57	85	89	61	83	85	89	61	83			
50	2	61	69	99	104	73	97	99	104	73	97			
65	2 1/2	77	85	119	124	89	117	119	124	89	117			
80	3	90	98	129	134	102	127	135	140	102	133			
90	3 1/2	103	111	140	144	115	138	148	150	115	146			
100	4	116	124	155	159	128	153	163	165	128	161			
125	5	143	151	185	190	155	183	198	203	155	196			
150	6	170	178	215	220	182	213	233	238	182	231			
175	7	192	200	240	245	204	238	—	—	204	—			
200	8	218	226	265	270	230	263	278	283	230	276			
225	9	243	251	285	290	255	283	—	—	255	—			
250	10	270	278	321	333	282	319	345	356	282	343			
300	12	320	328	370	378	332	368	395	406	332	393			
350	14	355	363	415	423	367	413	436	450	367	434			
400	16	406	414	471	486	418	469	487	510	418	485			
450	18	456	464	530	541	468	528	556	575	468	554			
500	20	509	517	583	596	521	581	609	630	521	607			
550	22	560	568	635	650	572	633	665	684	572	663			
600	24	611	619	684	700	623	682	716	734	623	714			

*This gasket cannot be used for JIS B 2220, nominal pressure 20K, slip-on welded flanges at a nominal pressure of 10K, 16K and 20K, a nominal diameter of 10A - 40A, or a nominal pressure of 20K because the gasket I.D. (D₁) is inward of the flange I.D.

NAFLON™ PTFE cushion gaskets [High-temperature type] (TOMBO No.9010-NA-A-9)

■ Applicable gaskets

NAFLON PTFE cushion gaskets [High-temperature type]
"TOMBO No.9010-NA-A-9"

■ Applicable flange

JPI-7S-15 "Forged Steel Flanges for the Petroleum Industry"
API-Std 605 "Standard for Large-Diameter Carbon Steel Flanges"
ASME B16.5 "Pipe Flanges and Flanged Fittings"
ANSI B 16.5 "Steel pipe Flange"

*This dimension table has been prepared by Nichias based on JPI-7S-15-1999.

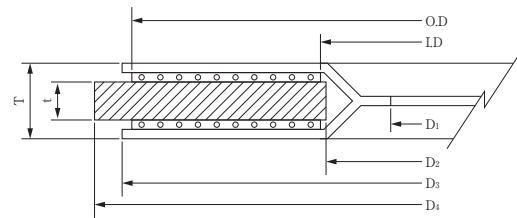

Type A

[Dimension Table 41]

Unit [mm]

Nominal flange diameter		D ₁	D ₂	Class 150				Class 300				t	T	Shape
				D ₃	D ₄	Mesh		D ₃	D ₄	Mesh				
A	B	I.D	O.D			I.D	O.D							
15	1/2	17	25	47	47	26	36	47	53	26	36	2.0	3.9	Type A
20	3/4	22	30	56	56	31	42	56	66	31	42			
25	1	28	36	66	66	38	50	66	72	38	50			
32	1 1/4	36	44	75	75	49	63	75	82	49	63			
40	1 1/2	42	50	85	85	55	72	85	94	55	72			
50	2	53	61	92	104	70	90	92	110	70	90			
65	2 1/2	66	74	105	123	83	103	105	129	83	103			
80	3	90	98	127	135	105	125	127	148	105	125			
90	3 1/2	103	111	140	161	118	138	140	164	118	138			
100	4	116	124	157	173	136	155	157	180	136	155			
125	5	143	151	186	196	164	184	186	215	164	184			
150	6	169	177	216	221	194	214	216	250	194	214			
200	8	220	228	270	277	242	268	270	306	242	268			
250	10	275	283	324	338	290	322	324	360	290	322			
300	12	326	334	381	408	347	379	381	420	347	379			
350	14	358	365	413	449	377	411	413	484	377	411			
400	16	408	416	470	512	432	468	470	538	432	468			
450	18	459	467	533	547	487	531	533	595	487	531			
500	20	510	518	584	604	537	582	584	651	537	582			
600	24	612	620	692	715	637	690	692	772	637	690			

*This gasket cannot be used for JPI-7S-15 slip-on type flange that has a nominal diameter of 2 1/2B (65A) or less because the gasket I.D. (D1) is inward of the flange I.D.

Plastic flanges

For 10K

■ Applicable gaskets

Ebilon™ gasket [covered with PTFE] "TOMBO No.9013, 9013-D"
 Ebilon gasket [uncovered rubber] "TOMBO No.9013-EP, 9013-DEP"

■ Applicable flanges

Plastic 10K flanges
 (PVC flanges made by Kubota, Sekisui Chemical, AOC)

*The dimensions of these gaskets have been set by Nichias according to the I.D. of the plastic flanges, based on JIS B 2210 "Reference Dimensions of Cast Iron Pipe Flanges" 10K flanges.

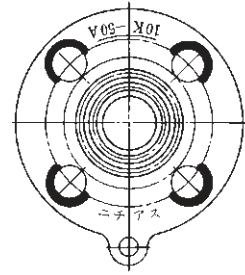
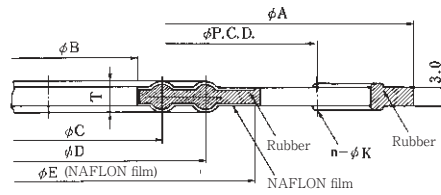

[Dimension Table 42]

Unit [mm]

Nominal flange diameter		Gasket		Thickness T	Diameter of sealing part		Bolt		Reference E
A	B	O.D. A	I.D. B		C	D	PCD	n-φK	
15	1/2 B	93	18	5	26	41	70	4-15	53
20	3/4	98	22	5	32	47	75	4-15	58
25	1	123	30	5	38	53	90	4-19	68
30/32	1 1/4	133	37	5	50	65	100	4-19	78
40	1 1/2	138	43	5	54	69	105	4-19	82
50	2	153	54	5	68	83	120	4-19	96
65	2 1/2	173	69	5	86	101	140	4-19	116
80	3	183	80	5	98	112	150	8-19	124
100	4	208	102	5	120	138	175	8-19	150
125	5	248	127	5	145	166	210	8-23	180
150	6	278	150	5	168	190	240	8-23	210
200 *1	8	328	198	5	216	247	290	12-23	260
250	10	398	249	5	270	306	355	12-25	326
300	12	443	300	5	324	352	400	16-25	372

*1: If these gaskets are used with a JIS B 2210 steel flange or a JIS 2220 steel welded flange, the sealing part will drop off to the I.D. side of the flange, so be careful.

For Class 150

■ Applicable gaskets

Ebilon™ gasket [covered with PTFE] "TOMBO No.9013, 9013-D"
 Ebilon gasket [uncovered rubber] "TOMBO No.9013-EP, 9013-DEP"

■ Applicable flanges

JPI-7S-15-85
 specified in "Forged steel flange for petroleum industry" of
 JPI standard

*The dimensions of these gaskets have been set by Nichias
 based on the butt-welded flanges stipulated in JPI-7S-15-85.

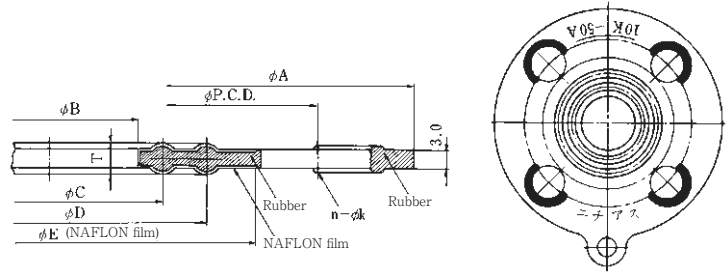

[Dimension Table 43]

Unit [mm]

Nominal flange diameter		Gasket			Diameter of sealing part		Bolt		Reference E
A	B	O.D. A	I.D. B	Thickness T	C	D	PCD	n-φK	
15	1/2	86	18	5	30	—	60	4-16	42
20	3/4	96	22	5	30	42	70	4-16	52
25	1	105	29	5	37	50	79	4-16	60
(32)	(1 1/4)	115	38	5	46	59	89	4-16	70
40	1 1/2	125	43	5	53	68	98	4-16	79
50	2	150	54	5	64	83	121	4-19	99
65	2 1/2	175	69	5	81	101	140	4-19	118
80	3	188	80	5	92	112	152	4-19	130
(90)	(3 1/2)	213	90	5	110	134	178	8-19	154
100	4	226	103	5	124	148	190	8-19	168
(125)	(5)	252	129	5	150	174	216	8-22	190
150	6	277	153	5	172	196	241	8-22	212
200	8	340	200	5	222	246	298	8-22	270
250	10	404	254	6	276	300	362	12-25	330
300	12	480	305	6	335	365	432	12-25	400
350	14	530	337	6	365	395	476	12-29	440
400	16	594	387	6	425	455	540	16-29	500
450	18	632	438	6	475	505	578	16-32	538
500	20	696	489	6	525	555	635	20-32	595
600	24	810	591	6	625	665	749	20-35	706

Basic Items Concerning Gaskets

■ Gasket tightening criteria

It is very important from the viewpoint of safety to tighten gaskets using an appropriate force and tightening method.

The numeric values "Wm₁" and "Wm₂" which are stipulated in "JIS B 8265 (Construction of pressure vessel -- General principles)" are generally used as a rough guide for the necessary tightening force for sealing the internal fluid.

However, depending upon the type of fluid and the conditions of use, the tightening force calculated by "Wm₁" and "Wm₂" may sometimes be insufficient, so Nichias has set an additional value "Wm₃."

When tightening a gasket, it is necessary to apply a force that is at least the largest of the values "Wm₁," "Wm₂," and "Wm₃."

■ Way of thinking concerning calculation of tightening

- Effective diameter and effective width of a gasket -

A flange bends slightly (flange rotation) due to tightening of the bolts and internal pressure, causing the convex part to swell, as shown in the diagram.

As a result, the contact pressure applied to the gasket becomes stronger on the O.D. side and weaker on the I.D. side, and it is considered that this causes the internal fluid to seep to the center part of the gasket. This is taken into account in the determination of the effective diameter and effective width of the gasket.

● Effective width of a gasket:

This is the gasket width of the part that actually seals the flange.

● Effective diameter of a gasket:

This is the diameter of the part to which the internal fluid seeps.

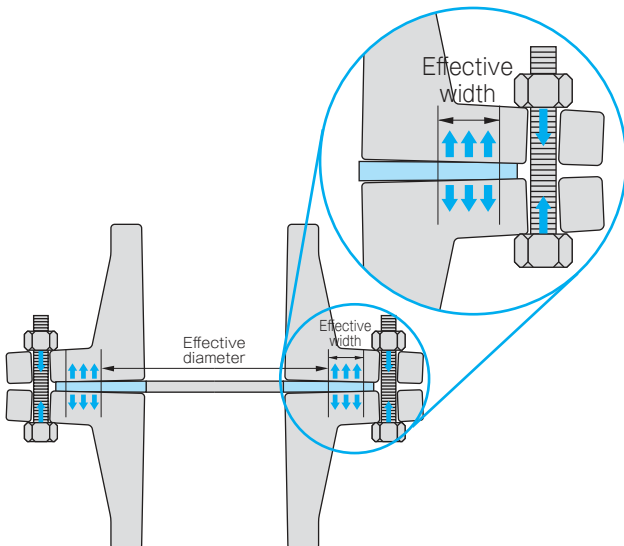

■ Determining the effective diameter and effective width of a gasket

● First, consider the basic width (b₀) of the gasket.

The basic width of the gasket differs according to the shape of the gasket seat. Generally, it is one half of the gasket contact width.

$$b_0 = \text{Gasket contact width} / 2$$

● Effective width of gasket (b)

Using the basic width of the gasket as a rough guide, obtain the effective width of the gasket using the following equation.

$$\text{When } b_0 \leq 6.35\text{mm } b = b_0$$

$$\text{When } b_0 > 6.35\text{mm } b = 2.52\sqrt{b_0}$$

● Effect diameter of gasket (G)

Using the basic width of the gasket as a rough guide, obtain the effective diameter of the gasket using the following equation.

$$\text{When } b_0 \leq 6.35\text{mm}$$

$$G = \text{Mean diameter of the gasket contact face}$$

$$\text{When } b_0 > 6.35\text{mm}$$

$$G = \text{O.D. of gasket contact face} - 2b$$

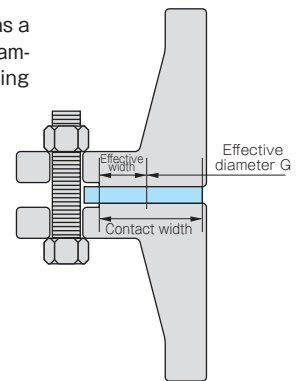

■ Meaning of Wm₁, Wm₂, and Wm₃

● Wm₁ is the necessary minimum tightening force [N] for preventing the flange from opening under internal pressure. It is obtained using the following equation.

$$Wm_1 = H + Hp$$

H: Force (H) tends to open the flange due to internal pressure. This force is called end force (internal pressure reaction).

$$H = \frac{\pi}{4} G^2 P$$

Hp: Necessary force for sealing the fluid when internal P exists

$$Hp = 2\pi b G m P$$

Over the effective area of the gasket, Hp becomes m (gasket coefficient) times the internal pressure P. Normally a value of twice this is used in the calculation in order to provide a safety margin.

$$\text{This is summarized in the following equation.}$$

$$Wm_1 = H + Hp = \frac{\pi G P}{4} (G + 8bm)$$

● Wm₂ is the necessary minimum tightening force [N] for preventing leakage due to penetration or through contact surfaces. It is obtained using the following equation.

$$Wm_2 = \pi b G y$$

● Wm₃ is the necessary minimum tightening force [N] which takes account of the contact area of the gasket. It is obtained using the following equation.

$$Wm_3 = \sigma_3 A_g$$

P = Internal pressure (MPa)

b = Effect width of gasket [mm]

G = Effective diameter of gasket

m = Gasket coefficient [-] (The ratio between the minimum effective tightening pressure at which leakage does not occur, and the internal pressure)

y = Minimum design seating stress [N/mm²]

σ₃ = Minimum seating stress [N/mm²]

A_g = Gasket contact area (projected area) [mm²]

Gasket tightening force

Take the gasket tightening force as the maximum of W_{m1} , W_{m2} and W_{m3} . Note, however, that it is necessary to ensure that this value is no greater than the allowable seating stress, to prevent compression failure of the gasket.

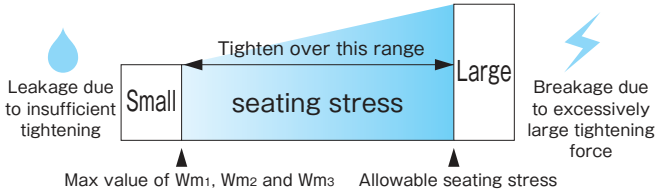

Calculating the tightening torque

The tightening torque of the bolts is calculated from the maximum value [W_{max}] of W_{m1} , W_{m2} and W_{m3} .

$$T = \frac{1}{1000} K \frac{W_{max}}{n} D$$

T = Tightening torque of bolts [N·m]
 K = Torque coefficient [-] (Normally 0.20)
 n = Number of bolts [-]
 D = O.D. of bolts [mm]

JIS B 2251-2008 Bolt tightening for pressure boundary flanged joint assembly

A widely used method of tightening the bolts is called "diagonal tightening." This method involves tightening diagonally opposite pairs of bolts in sequence. In 2008, however, JIS B 2251 which covered the method of tightening joint sheets and also the flange coupling of vortex™ type gaskets was enacted. This method is described below.

<Introduction>

Install a gasket correctly centered on the gasket seat to ensure that it is not tightened unevenly. Use a torque wrench to control the tightening torque.

<Temporary tightening>

If there are 8 or less flange bolts, temporarily tighten the bolts using the following procedure. If there are 12 or more bolts, select the bolts to be temporarily tightened according to Table 1, and tighten the bolts in the same way as that for 8 or less bolts.

- ① Tighten diagonally opposite pairs of bolts in sequence, as shown in Fig. 1.
- ② Increase the tightening torque in stages (for example 10% → 20% → 60% → 100%), and tighten the bolts evenly.
- ③ Using vernier calipers, measure the clearance between the flange faces at 4 diagonally opposed locations, and check to ensure that the bolts are not tightened unevenly.

- * In the case of a vortex gasket, at the end of temporary tightening, tighten all bolts to 50% of the target torque in the clockwise direction rotation (to prevent uneven tightening).
- * Setting the target tightening torque
 When there are 8 or less bolts: 100% of the specified tightening torque
 When there are 12 or more bolts: 110% of the specified torque

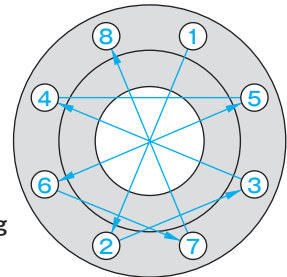

Fig.1 Diagonal tightening procedure

Table 1 Bolt selection criteria

Number of flange bolts	Selection criterion
12 or more, up to 24	4 bolts equally spaced at 90°
Over 24	4 bolts equally spaced by 90°, and 4 bolts separated by 45° from each of the first 4 bolts (Total of 8 bolts)

<Final tightening>

- ① If there are 4 flange bolts, tighten diagonally to 100% of the specified torque.
- ② If there are 8 or more flange bolts, tighten them clockwise the number of turns indicated in the table below.

Nominal flange diameter	Number of turns
Less than 250A	4 turns
250A or more	6 turns

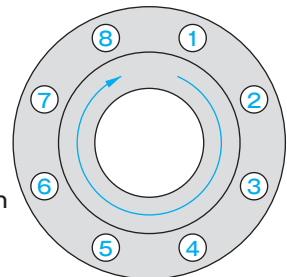

Fig.2 Tightening in the clockwise direction

<Additional tightening>

If it is necessary to additionally tighten the bolts, wait for at least 4 hours after the completion of final tightening, and then tighten the bolts an additional 1 to 2 turns using the same procedure.

Gasket design criteria list

Joint sheet

TOMBO No.		1120	1995	1993	
Gasket coefficient m [-]	0.8 t		3.50		
	1.5 t		2.75		
	3.0 t		2.00		
Min design seating stress y [N/mm ²]	0.8 t		44.8		
	1.5 t		25.5		
	3.0 t		11.0		
Min seating stress σ_3 [N/mm ²]	Water-type and oil-type fluids		14.7		
	Gas-type fluids		34.3		
Allowable seating stress	Without paste [N/mm ²]	0.8 t	294.2		
		1.5 t	196.1		
		3.0 t	98.0	147.1	
	With paste [N/mm ²]	0.8 t	68.6 ^{*1}		
		1.5 t	68.6 ^{*1}		
		3.0 t	68.6 ^{*1}		

*1: The allowable seating stress when anti-corrosion paste is used is 58.8 N/mm².

Fluoro-resin gaskets

TOMBO No.	1133	9007-SC	9007-LC	9007-GL	9007-FD	9096-SGM	9007	9007-LP	9007-G20	
Gasket coefficient m [-]	1.0 t	3.50	—	3.50	—	—	2.50	3.50	—	3.50
	1.5 t	2.75	3.20	3.20	—	—	2.50	3.20	—	3.20
	2.0 t	2.75	3.00	3.00	—	—	2.50	3.00	3.00	3.00
	3.0 t	2.00	2.50	2.50	2.50	2.50	2.50	2.50	—	2.50
Min. design seating stress y [N/mm ²]	1.0 t	44.8	—	24.5	—	—	19.6	24.5	—	24.5
	1.5 t	25.5	22.6	22.6	—	—	19.6	22.5	—	22.5
	2.0 t	25.5	19.6	19.6	—	—	19.6	19.6	19.6	19.6
	3.0 t	11.0	19.6	19.6	19.6	19.6	19.6	19.6	—	19.6
Min. seating stress σ_3 [N/mm ²]	Water-type and oil-type fluids	14.7	14.7	14.7	19.6	19.6	19.6	10.8	14.7	12.7
	Gas-type fluids	34.3	29.4	24.5	14.7	—	39.2	19.6 ^{*1} 14.7 ^{*2}	14.7	19.6 ^{*1} 14.7 ^{*2}
Allowable seating stress	150.0	58.8	49.0	39.2	39.2	117.6 ^{*3}	39.2	29.4	49.0	

*1: Minimum seating stress for thickness of 1.0 t or 1.5 t *2: Minimum seating stress for thickness of 2.0 t or 3.0 t *3: Allowable seating stress for thickness of 2.0 t or 3.0 t is 78.4 N/mm².

NAFLON™ PTFE cushion gaskets

Shape	Type A		Type B	Type AS	
Type of core material [TOMBO No.]	1995 (Type 5) 1995+Felt (Type 6) 1120 (Type 7) 1120+Felt (Type 8)	1120+SUS mesh (Type 9)	1995 (Type 5) 1995+Felt (Type 6) 1120 (Type 7) 1120+Felt (Type 8)	1995 (Type 5) 1995+Felt (Type 6) 1120 (Type 7) 1120+Felt (Type 8)	1120+SUS mesh (Type 9)
Gasket coefficient m [-]	3.50	3.50	4.00	3.50	3.50
Min. design seating stress y [N/mm ²]	14.7	19.6	19.6	14.7	19.6
Min. seating stress σ_3 [N/mm ²]	Water-type and oil-type fluids	9.8	14.7	9.8	14.7
	Gas-type fluids	14.7	19.6	14.7	19.6
Allowable seating stress	29.4	39.2	29.4	29.4	39.2

GRASEAL™ gaskets

TOMBO No.	1880-GR	1215-A	1220-A	1200
Gasket coefficient m [-]	2.00	2.00	2.00	2.00
Min. design seating stress y [N/mm ²]	26.0	29.4	29.4	26.0
Min. seating stress σ_3 [N/mm ²]	Water-type and oil-type fluids	14.7	14.7	14.7
	Gas-type fluids	39.2	49.0	49.0
Allowable seating stress	0.8 t	—	294.0	170.0
	1.6 t	166.0	167.0	106.0
	3.2 t	166.0	98.0	79.0

■ Kammprofile gaskets

TOMBO No.	1891-GR	1891-TF
Gasket coefficient m [-]	2.25	
Min design seating stress y [N/mm ²]	15.2	
Min seating stress σ ₃ [N/mm ²]	Water-type and oil-type fluids	29.4
	Gas-type fluids	39.2
Allowable seating stress [N/mm ²]	450	

■ Vortex™ gaskets

TOMBO No.*1	1804-GR	1804-NA	9090	1806-GS, -GM, -GH	1809, 1809-A L
Gasket coefficient m [-]	3.00				3.00
Min design seating stress y [N/mm ²]	68.9				58.8
Min seating stress σ ₃ [N/mm ²]	Water-type and oil-type fluids	29.4	34.3	29.4	34.3
	Gas-type fluids	39.2	78.4	39.2	78.4
Allowable seating stress [N/mm ²]	294.2				294.2

*1: Indicates the TOMBO No. for basic type.

■ Metal jacketed gaskets

TOMBO No.	1841-S	1841-E 1841-G, others	1841-C	1841-A	1861-S	1861-E 1861-G, others	1861-C	1861-A
Cover metal material	Carbon steel	304 steel 316 steel, others	Copper	Aluminum	Carbon steel	304 steel 316 steel, others	Copper	Aluminum
Gasket coefficient m [-]	3.75	3.75	3.50	3.25	3.00	3.50	3.25	2.50
Min. design seating stress y [N/mm ²]	52.4	62.1	44.8	38.0	31.0	44.8	38.0	20.0
Min. seating stress σ ₃ [N/mm ²]	Water-type and oil-type fluids	39.2	49.0	34.3	29.4	—	—	—
	Gas-type fluids	101.4	120.4	76.2	58.8	—	—	—

■ Plane type metal gaskets

TOMBO No.	1850-P-S	1850-P-E, P-G, others	1850-P-C	1850-P-A
Material	Carbon steel	304 steel, 316 steel, others	Copper	Aluminum
Gasket coefficient m [-]	5.50	6.50	4.75	4.00
Min. design seating stress y [N/mm ²]	124.2	179.3	89.6	60.7
Min. seating stress σ ₃ [N/mm ²]	Water-type and oil-type fluids	98.1	117.7	58.8
	Gas-type fluids	235.4	343.2	98.1

■ Serrated metal gaskets

TOMBO No.	1890-S	1890-E, 1890-G, others	1890-C	1890-A
Material	Carbon steel	304 steel, 316 steel, others	Copper	Aluminum
Gasket coefficient m [-]	3.75	4.25	3.50	3.25
Min. design seating stress y [N/mm ²]	52.4	69.6	44.8	38.0

■ Ring joint gaskets

TOMBO No.	1850-C-D, 1850-V-D	1850-C-S, 1850-V-S	1850-C-F, 1850-V-F	1850-C-E, 1850-C-G 1850-V-E, 1850-V-G, others
Material	Pure iron	Mild steel	F5	Stainless steel
Gasket coefficient m [-]	5.50		6.00	6.50
Min. design seating stress y [N/mm ²]	124.2		150.3	179.3

Gasket standard dimension list

Joint sheets

TOMBO No.		1120	1995	1993	1991-NF	1938
1S (1270×1270mm)	0.4 t	●	—	—	●	—
	0.5 t	●	—	●	●	—
	0.8 t	●	●	●	●	—
	1.0 t	●	●	●	●	●
	1.5 t	●	●	●	●	●
	2.0 t	●	●	●	—	●
3S (1270×3810mm)	0.4 t	●	—	—	●	—
	0.5 t	●	—	●	●	—
	0.8 t	●	●	●	●	—
	1.0 t	●	●	●	●	—
	1.5 t	●	●	●	●	—
	2.0 t	●	●	●	—	—
6S (2540×3810mm)	0.8 t	●	●	—	—	—
	1.0 t	●	●	—	—	—
	1.5 t	●	●	—	—	—
	2.0 t	●	●	—	—	—
	3.0 t	●	●	—	—	—
9S (3810×3810mm)	0.8 t	—	●	—	—	—
	1.0 t	—	●	—	—	—
	1.5 t	—	●	—	—	—
	2.0 t	—	●	—	—	—
Weight per sheet of thickness 1.5 t and 1S size [kg] (reference value)		3.63	4.35	4.23	3.75	4.35

*The above dimensions are standard dimensions. Note that we may be able to manufacture joint sheets of dimensions that are not marked with ●. Please contact us for details.

Fluoro resin gaskets

TOMBO No.	1133	9007-SC	9007-LC	9007-GL	9007-FD	9096-SGM	9007	9007-LP	9007-G20
Max O.D. [mm]	1.0 t	φ610	—	φ1200	—	φ1380	φ1200	φ277	φ1200
	1.5 t	φ1250	φ1200		—				
	2.0 t	—	—	—	—				
	3.0 t	φ1430	φ1200	φ1430	φ600				
Standard thickness	1.0 t	●	—	●	—	●	●	—	●
	1.5 t	●	●	●	—	●	●	—	●
	2.0 t	●	●	●	—	●	●	●	●
	3.0 t	●	●	●	●	●	●	—	●

*The pale blue parts in the table indicate that the gaskets concerned can be manufactured to a larger bore than indicated, by carrying out welding work.

NAFLON™ PTFE cushion gaskets

Shape	Type A	Type B	Type AS
Min I.D. [mm]	φ16	φ300	φ20
Max O.D. [mm]	φ1000	Arbitrary	φ700

GRASEAL™ gaskets

TOMBO No.	1880-GR	1215 1215-T	1215-A 1215-AT	1215-B-E04 1215-BT-E04	1215-B-E10 1215-BT-E10	1210-A	1200
Nominal thickness [mm]	1.6, 3.2	0.8, 1.6, 3.2	0.8, 1.6, 3.0	1.2, 2.0	1.8, 2.6	1.5, 2.0, 3.0	0.4, 0.8, 1.6, 3.2
Thickness of reinforcing sheet [mm]	0.8	0.10	0.05	0.40	1.00	0.10	—
Diameters to which gaskets can be manufactured [mm]	φ3300 ^{*1}	φ580	φ1480 ^{*3}	φ985 ^{*2}	φ985 ^{*2}	φ1480	φ985
Min width [mm]	10	10	5	5	10	—	—

*1: For a dimension that exceeds φ3300, please consult us.

*2: If the O.D. of the gasket exceeds 900 mm, weld a steel sheet of 0.4 mm or 1.0 mm at several points, or bond an expanded graphite sheet at several points.

*3: The maximum diameter dimension to which a gasket of nominal thickness of 0.8 mm can be manufactured is φ985 mm.

Kammprofile gaskets

Standard O.D. [mm]	φ4000 ^{*1}
Standard thickness [mm]	4.0 (Metal thickness: 3.0, Thickness of cover material: 0.5×2 = 4.0)
Standard width [mm]	10, 13, 15, 20
Min width to which gasket can be manufactured [mm]	5 ^{*2}
Standard metal body material	304 steel, 316L steel
Standard hanger material	304 steel
Construction	Standard type, hanger type, branch type

*1: For a diameter exceeding φ4000 mm, please consult us. We can also manufacture gaskets to specifications other than those shown at left, as special products.
Note, however, that from a structural viewpoint, we are unable to manufacture a gasket with bolt holes for a full-face seat or one with an irregular profile (track type, oval type, etc.). In such a case, please consider the use of TOMBO™ No.1880-GR (CMGC gasket).

*2: Indicates the minimum width to which a gasket can be manufactured. The sealable width differs depending upon the conditions of use, so please be careful.

Vortex™ gaskets

Gasket thickness ^{*1} [mm]	Inner/outer ring thickness [mm]		Recommended I.D. for manufacture ^{*2} [mm]	
	Carbon steel	Other than carbon steel	Min.	Max.
3.2	2.0	2.0	φ 16	φ 600
4.5 (Standard)	3.2	3.0	φ 16	φ 3000
6.4	4.5	4.0	φ 1500	φ 3000

*1: When using this gasket for a pipe flange, use a gasket thickness of 4.5 mm, as a general rule.

*2: We can also manufacture gaskets to dimensions other than the above. Note, however, that this may result in deformation, warping or breaking up of the gaskets, and also the delivery period may be longer than normal due to the custom specifications, so please consult us separately.

Metal jacketed gaskets

Cover metal material	Carbon steel	304 steel	316 steel	Copper	Aluminum	310S steel
Material symbol	S	E	G	C	A	V
Standard dimensions [mm]	1480	1180	1180	1180	980	1180

* Indicates the larger diameter to which a gasket can be manufactured using a single metal sheet. We can manufacture larger gaskets by welding at two or more points.

Metal O seals

Tube cross-sectional diameter [mm]	Thickness [mm]	O.D. [mm]	
		Recommended range of use	Manufacturable dimensions
φ0.8	0.15	6 ~ 25	6 ~ 30
φ1.6	0.25	—	10 ~ 200
	0.36	15 ~ 50	11 ~ 200
φ2.4	0.25	—	40 ~ 500
	0.46	40 ~ 200	20 ~ 500
φ3.2	0.25	—	60 ~ 1500
	0.35 ^{*1}	—	60 ~ 1500
	0.5	65 ~ 700	50 ~ 1500
φ4.8	0.5 ^{*1}	—	150 ~ 1500
	0.8	500 ~ 1200	150 ~ 1500
φ6.4	0.8	1000 ~ 1500	250 ~ 1500 ^{*2}

 Indicates the standard thickness. In the case of a gas seal, use the seal with standard thickness.

 The minimum O.D. of a vent-hole type is φ 10 mm.

 The maximum O.D. of a PTFE coating is φ 1300, and that of a silver coating is φ 1100.

*1: The manufacturable tube material is limited to SUS321 steel.

*2: If you require a gasket exceeding 1500 mm, please consult us.

Minimum value of the corner rounding in the case of a square gasket

For a standard thickness ( part)

R at the I.D. side ≤ 6 times the O.D. of the tube

When the thickness is thinner than the standard value

R at the I.D. side ≤ 8 times the O.D. of the tube

Rubber cut gaskets

Thickness [mm]	Width [mm]	Max O.D. [mm]
1.0	1,000	φ 10,000
1.5		
2.0		
3.0		
5.0		
10.0		

* The maximum O.D. for ZR or PF of a thickness of 1.0 mm, 1.5 mm, 2.0 mm or 3.0 mm is φ 300 mm.

* The minimum thickness of a cloth filled NR is 1.5 mm.

Saniclean™ gaskets

Nominal dimension [inches]	TOMBO No.					
	9014-A (for screw coupling) [mm]			9014-B (for ferrule) [mm]		
	φA	φB	φC	φA	φB	φC
1	32.5	29.2	23.0	49.5	43.5	23.1
1 1/2	46.0	42.7	35.6	49.5	43.5	35.8
2	59.5	56.2	47.8	63.0	56.5	48.0
2 1/2	73.0	69.9	59.5	76.5	70.5	59.7
3	86.5	82.6	72.1	90.0	83.5	72.3
4	112.5	108.3	97.6	118.0	110.0	97.8

* The standard dimensions of TOMBO No.9014-A, B are determined based on the IDF standard. Note, however, that you can also use these gaskets for screw coupling and clamp type couplings that conform to ISO2852 and ISO2853.

Ebilon gaskets

- Plastic flanges (equivalent to JIS 10K) 15A - 300A
- JPI Class 150 1/2 - 24B

Rubber O rings

- JIS B 2401 "O rings"
- AS 568B "O rings for hydraulic applications in aircraft"
- JIS B 8365 "Dimensions of clamped-type vacuum couplings"

Note



■ **Head Office**

1-26, Shibadaimon 1-Chome, Minato-ku, Tokyo 105-8555, Japan
International Marketing and Sales Group
 PHONE: 81-3-3433-7261 FAX: 81-3-3438-0670

■ **Head Office**

6-1, Hatchobori 1-Chome, Chuo-ku, Tokyo 104-8555, Japan
International Marketing and Sales Group
 Phone: 81-3-4413-1132 / 7262 Fax: 81-3-3552-6108
 Web Site: <http://www.nichias.co.jp/>

■ **Overseas Representative Offices**

Malaysia

NICHIAS CORPORATION, MALAYSIA REGIONAL OFFICE
 Suite A1102, 11th Floor, West Wing, Wisma Consplant 2,
 No. 7, Jalan SS 16/1, 47500 Subang Jaya, Selangor Darul Ehsan, Malaysia.
 Tel : +60-3-5636-5778 Fax : +60-3-5636-5786

Qatar

NICHIAS CORPORATION, QATAR REPRESENTATIVE OFFICE
 P.O. Box 200138, 7th Floor Pearl Tower, Al Matar Street, Doha, Qatar
 Phone: +974-4498-7221 Fax: +974-4443-5495

■ **Overseas Sales Companies**

Indonesia

PT. NICHIAS SUNIJAYA
 Panin Life Center, 2nd Floor, Room 205, Jl. Letnan Jenderal S. Parman
 Kav. 91, Jakarta 11420, Indonesia
 Phone: +62-21-56956207 Fax: +62-21-56956208/56956209

Malaysia

NICHIAS FGS SDN. BHD. Kuala Lumpur Sales Office
 Suite A1102, 11th Floor, West Wing, Wisma Consplant 2, No.7, Jalan
 SS 16/1, 47500 Subang Jaya, Selangor, Malaysia
 Phone: +60-3-5636-4067 Fax: +60-3-5636-4078

Singapore

NICHIAS SINGAPORE PTE. LTD.
 25 International Business Park, #01-15/17 GERMAN CENTRE,
 Singapore 609916
 Phone: +65-6571-0830/0838 Fax: +65-6265-7681

Vietnam

NICHIAS VIETNAM CO., LTD
 R04, Fl.2, Newlife building, No.6 Nguyen Thi Thap Street,
 Trung Hoa ward, Cau giay district, Hanoi, Vietnam
 Phone: + 84-4-3791-7194 Fax: + 84-4-3791-6203

Thailand

NICHIAS (THAILAND) CO., LTD.
 85 Moo 1, Wellgrow Industrial Estate T. Homsin, A. Bangpakong
 Chachoengsao 24180, Thailand
 Phone: +66-38-570-600 Fax: +66-38-570-601

China

NICHIAS (SHANGHAI) TRADING CO., LTD.
 2109 Building A, City Center of Shanghai, No.100 Zun Yi Road,
 Changning District, Shanghai, 200051, P.R.China
 中国上海市长宁区遵义路100号虹桥上海城A栋2109室 邮编200051
 Phone: +86-21-62361783 Fax: +86-21-62361781

NICHIAS (SHANGHAI) TRADING CO., LTD. Guangzhou Branch
 2109 Building A, City Center of Shanghai, No.100 Zun Yi Road,
 17F-G, Gold Sun Building, No.109 Tiyu West Road, Guangzhou,
 Guang Dong Province, 510620, P.R.China
 中国广东省广州市天河区体育西路109号高盛大厦17楼G室 邮编 510620
 Phone: +86-20-3879-1640 Fax: +86-20-3879-1647

NICHIAS (SHANGHAI) AUTOPARTS TRADING CO., LTD.
 2108 Building A, City Center of Shanghai, No.100 Zun Yi Road,
 Changning District, Shanghai, 200051, P.R.China
 中国上海市长宁区遵义路100号虹桥上海城A栋2108室 邮编200051
 Phone: +86-21-6236-2668 Fax: +86-21-6236-2667

■ **Overseas Construction Companies**

Thailand

THAI-NICHIAS ENGINEERING CO., LTD.
 45 Huaypong-Nongbon Road, Huaypong, Muang Rayong,
 Rayong Province 21150, Thailand
 Phone: +66-38-682-242 Fax: +66-38-691-156

■ **Overseas Factories**

Indonesia

PT. NICHIAS ROCKWOOL INDONESIA
PT. NICHIAS METALWORKS INDONESIA

Malaysia

NICHIAS FGS SDN. BHD.
NT RUBBER-SEALS SDN. BHD.

Vietnam

NICHIAS HAIPHONG CO., LTD.

China

SUZHOU NICHIAS INDUSTRIAL PRODUCTS CO., LTD.
 (苏州霓佳斯工业制品有限公司)

SUZHOU NICHIAS SEAL MATERIAL CO., LTD.
 (苏州霓佳斯密封材料有限公司)

SHANGHAI XINGSHENG GASKET CO., LTD.
 (上海兴盛密封垫有限公司)

SHANGHAI GOYU AUTO PARTS CO., LTD.
 (上海五友汽车零部件有限公司)

India

NICHIAS INDUSTRIAL PRODUCTS PRIVATE LTD.

Czech

NICHIAS Czech s.r.o.

 **Cautions**

- 1) The information and recommendation in this catalog are based on our present state of knowledge and given in good faith for customer guidance purpose, and no liability will be accepted in relation to the same.
- 2) Properties/applications shown in this catalog are typical. The products shown in this catalog shall not be used for any purpose other than prescribed application.
- 3) Performance data shown in this catalog are developed from in-house testing and/or field reports from customers. Failure to select the proper products could result in property damage and/or serious personal injury.
- 4) Performance verification under actual operating conditions is recommended even for the application shown in this catalog.
- 5) While the utmost care has been used in compiling this catalog, we assume no responsibility for errors. This edition cancels previous issues and contents of this catalog are subject to change without prior notice.
- 6) For safe handling recommendations and health related effects, refer to the material safety data sheet (MSDS) of each product, available on request.
- 7) All or any part of the content on this catalog may not be copied, duplicated, imitated, reused and reproduced without prior permission of NICHIAS Corporation.